

BUILD A VIDEO TELEPHONE!

Radio Electronics®

APRIL 1991

TECHNOLOGY - VIDEO - STEREO - COMPUTERS - SERVICE

BUILD A MAGNETIC-FIELD METER

Determine your exposure to potentially harmful ELF magnetic radiation

BUILD A 40-WATT POWER INVERTER

Power 120-volt AC devices from 12 volts DC!

EXPERIMENTS IN VOICE RECOGNITION

Single IC can be used in an assortment of projects

SWITCHING REGULATORS

The basics of switching power supply design

BUILD A STEPPER MOTOR ROBOT

Based on the 8748 microcontroller



\$2.95 U.S.
\$3.75 CAN

A
GERNSBACK
PUBLICATION

***** CAR-RT SORT ** CR24
390736DHMD997G093 D4 21
JAN 92 RE
MR ROBERT DAHM
997 GRAND AV
AURORA, IL 60506

FLUKE



PHILIPS

High Resolution Digital Meter:
4000 count digital readout; 20,000 count mode (Fluke 87) for 4 1/2 digit resolution

Backlit display: Makes it easy to read the DMM in dark, cramped quarters. Automatically shuts off after 68 seconds to save the battery.

Recorder: records minimums and maximums, plus true arithmetic average; audible Min Max Alert; selectable response times—1 second and 100 ms (all models) plus 1 ms Peak Min Max (Fluke 87)

Holster with Flex Stand™: Protects meter and provides test lead storage. Flexible leg allows meter to be hung from peg, bent around a pipe, or used almost anywhere.

Analog Meter: High-speed analog display updates 40 times/second—as fast as the eye can follow; X10 Zoom bargraph mode (Fluke 83 and 85) makes high resolution offset measurements a snap.

Frequency counter: Accurate down to 0.5 Hz; also measures duty cycle

Capacitance meter: Autoranging, with manual ranging at the touch of a button



FLUKE 83	FLUKE 85	FLUKE 87
Volts, ohms, amps, diode test, audible continuity, frequency and duty cycle capacitance, Touch Hold® relative, protective holster with Flex-Stand™	Volts, ohms, amps, diode test, audible continuity, frequency and duty cycle capacitance, Touch Hold® relative, protective holster with Flex-Stand™	Volts, ohms, amps, diode test, audible continuity, frequency and duty cycle capacitance, Touch Hold® relative, protective holster with Flex-Stand™
\$199*	\$229*	\$289*
0.3% basic dc accuracy	0.1% basic dc accuracy	0.1% basic dc accuracy
5 kHz acV	20 kHz acV	20 kHz acV
Analog bargraph and zoom	Analog bargraph and zoom	High resolution analog pointer
Three year warranty	Three year warranty	True-rms ac
		1 ms PEAK MIN MAX
		4 1/2 digit mode
		Backlit display
		Three year warranty

*Suggested U.S. list price

Multi-Meter

Meet the meter that brings an entire test bench to your job. The versatile Fluke 80 Series do-just-about-everything "Multi" Meter.

It offers everything you'd expect from an advanced handheld DMM, plus a lot you'd find only in dedicated instruments. *Plus* Fluke-exclusive features you can't buy anywhere else. All built with the most advanced surface mount design and single-chip ASIC technology for a thinner, tougher, more reliable package.

There's a fully annunciated display for clear operation. Duty cycle function. High-speed analog indicator. A protective holster with innovative Flex-Stand™ for easy, adaptable operation. Audible Input Alert™ to reduce the risk of damage to the meter, the user, and the unit being tested. Plus the strongest warranty in the business.

All good reasons to move up to the truly-multi Fluke 80 Series today. You'll find 80 Series DMMs at your Fluke distributor. For immediate, off-the-shelf delivery. Call

1-800-44-FLUKE, ext. 33 for the name of your nearest distributor.

John Fluke Mfg. Co., Inc. P.O. Box 9090 M/S 250C, Everett, WA 98206 U.S.: (206) 347-5400 CANADA: 416-890-7600 OTHER COUNTRIES: (206) 356-5500

© Copyright 1989, John Fluke Mfg. Co., Inc. All rights reserved. Prices and specifications subject to change without notice. Ad no. 0102-F80

FROM THE WORLD LEADER IN DIGITAL MULTIMETERS.

FLUKE

CIRCLE 121 ON FREE INFORMATION CARD

BUILD THIS

17 POOR MAN'S LASER PRINTER

Build your own and save big bucks!
Paul Renton

33 MAGNETIC FIELD METER

Use this easy-to-build gaussmeter to find out if you're being exposed to potentially dangerous magnetic fields.
Reinhard Metz

43 LINE POWER FROM 12 VOLTS

This 40-watt DC-to-AC inverter lets you run appliances from your car's cigarette lighter.
David Cuthbert

45 BUILD THIS VIDEO PHONE

Send and receive video pictures over standard phone lines!
Charles Colby

63 THE STEPPER-MOTOR ROBOT

Our friendly robot is a great teaching tool.
Fred Eady

TECHNOLOGY

27 FCC APPROVES NO-CODE

Now you can get a Technician-class Amateur Radio license without passing a Morse-code test!
Mike Stone W8OQCD

49 EXPERIEMENTS IN VOICE RECOGNITION

Two simple projects let you use voice commands to control things.
Daniel B. Cooper

57 INSIDE SWITCHING POWER SUPPLIES

Learn the basics of switching regulators.
Harry L. Trietley

DEPARTMENTS

6 VIDEO NEWS

What's new in this fast-changing field.
David Lachenbruch

18 EQUIPMENT REPORTS

Hewlett Packard 5600A
Portable Oscilloscope.

71 HARDWARE HACKER

New hackable project ideas, and more!
Don Lancaster

80 AUDIO UPDATE

Audio amplifiers: Do they sound different?
Larry Klein

85 COMPUTER CONNECTIONS

The evolution of standards.
Jeff Holtzman

AND MORE

98 Advertising and Sales Offices

98 Advertising Index

12 Ask R-E

13 Letters

88 Market Center

26 New Lit

22 New Products

4 What's News



Build a 40-watt DC-to-AC inverter and power AC appliances from your automobile cigarette lighter.

DAVID CUTHBERT

Build the new line... This device will allow you to run AC appliances from your car's cigarette lighter. It's a simple project that can be completed in a few hours. The inverter is powered by a 12VDC battery and can provide up to 40 watts of AC power. It's perfect for running small AC appliances like a radio or a small lamp. The project is described in detail in the article on page 43.

PAGE 43



Build this video telephone and send and receive video pictures over standard phone lines in the world!

CHARLES COLBY

Build a two-way videophone... This project allows you to send and receive video pictures over standard phone lines. It's a complex project that involves a lot of electronics and programming. The project is described in detail in the article on page 45.

PAGE 45

ON THE COVER



If you've been worrying that just about *everything* in your life can cause cancer, at least you can stop worrying that you're paranoid. Besides smog, red meat, cigarettes, radon gas, etc., studies have shown an increase in cancer rates in those who are exposed to even low-level magnetic fields. Electro-magnetic fields (ELF) are created by the generation, distribution, and use of electricity and electronic devices—meaning that you're exposed to it at home from everything ranging from your blow dryer to your microwave, as well as at work. Those who live close to power-distribution substations and power lines are considered to be particularly at risk. To find out if you and your family and co-workers are being exposed to potentially hazardous ELF levels, build the portable ELF gaussmeter shown on page 33.

COMING NEXT MONTH

THE MAY ISSUE GOES ON SALE APRIL 3.

BUILD THIS RAM TESTER

Verify that your memory is working properly and at the rated speed.

BUILD THE PHON-COM

Turn your telephones into a home intercom system.

MICROCELL

Is the "poor man's cellular network" the phone network of tomorrow?

BUILD THE PULSE MATE

A handheld pulse generator makes a handy troubleshooting tool.

As a service to readers, RADIO-ELECTRONICS publishes available plans or information relating to newsworthy products, techniques and scientific and technological developments. Because of possible variances in the quality and condition of materials and workmanship used by readers, RADIO-ELECTRONICS disclaims any responsibility for the safe and proper functioning of reader-built projects based upon or from plans or information published in this magazine.

Since some of the equipment and circuitry described in RADIO-ELECTRONICS may relate to or be covered by U.S. patents, RADIO-ELECTRONICS disclaims any liability for the infringement of such patents by the making, using, or selling of any such equipment or circuitry, and suggests that anyone interested in such projects consult a patent attorney.

RADIO-ELECTRONICS (ISSN 0033-7862) April 1991. Published monthly by Gernsback Publications, Inc., 500-B Bi-County Boulevard, Farmingdale, NY 11735 Second-Class Postage paid at Farmingdale, NY and additional mailing offices. Second-Class mail registration No. 9242 authorized at Toronto, Canada. One-year subscription rate U.S.A. and possessions \$17.97, Canada \$23.97, all other countries \$26.97. All subscription orders payable in U.S.A. funds only, via international postal money order or check drawn on a U.S.A. bank. Single copies \$2.95. © 1991 by Gernsback Publications, Inc. All rights reserved. Printed in U.S.A.

POSTMASTER: Please send address changes to RADIO-ELECTRONICS, Subscription Dept., Box 55115, Boulder, CO 80321-5115.

A stamped self-addressed envelope must accompany all submitted manuscripts and/or artwork or photographs if their return is desired should they be rejected. We disclaim any responsibility for the loss or damage of manuscripts and/or artwork or photographs while in our possession or otherwise.

Radio Electronics®

Hugo Gernsback (1884-1967) founder

Larry Steckler, EHF, CET,
editor-in-chief and publisher

EDITORIAL DEPARTMENT

Brian C. Fenton, editor

Marc Spiwak, associate editor

Kim Dunleavy,
assistant technical editor

Teri Scaduto, assistant editor

Jeffrey K. Holtzman
computer editor

Robert Grossblatt, circuits editor

Larry Klein, audio editor

David Lachenbruch
contributing editor

Don Lancaster
contributing editor

Kathy Terenzi, editorial assistant

ART DEPARTMENT

Andre Duzant, art director

Injae Lee, illustrator

Russell C. Truelson, illustrator

PRODUCTION DEPARTMENT

Ruby M. Yee, production director

Janice Box,
editorial production

Karen S. Brown
advertising production

Marcella Amoroso
production assistant

CIRCULATION DEPARTMENT

Jacqueline P. Cheeseboro
circulation director

Wendy Alanko
circulation analyst

Theresa Lombardo
circulation assistant

Michele Torrillo, reprint bookstore.

Typography by Mates Graphics

Cover photo by Jack McConnell and
Diversified Photo
Services

Radio-Electronics is indexed in
Applied Science & Technology Index
and *Readers Guide to Periodical Literature*.

Microfilm & Microfiche editions are
available. Contact circulation depart-
ment for details.

**Advertising Sales Offices listed
on page 98.**

Radio-Electronics Executive and
Administrative Offices
1-516-293-3000.

Subscriber Customer Service:
1-800-288-0652.

Order Entry for New Subscribers:
1-800-999-7139.

The
Audit
Bureau
of Circulation



RADIO SHACK

PARTS PLACESM



Talking Multimeter. Press a button on the probe and this meter calls out the reading while displaying it on a high-contrast LC display. Full auto-ranging, continuity sounder, diode-check mode. Low-battery and over-range indicators. #22-164 99.95

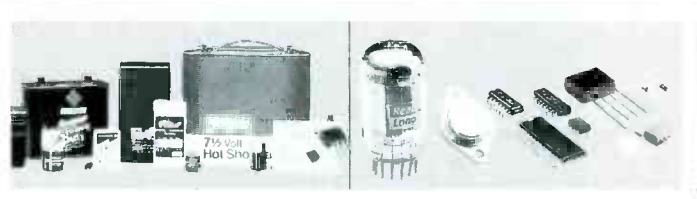

"HOTLINE" SPECIAL-ORDER SERVICE

Your nearby Radio Shack stocks over 1000 popular electronic parts and can special-order many items from our main warehouse—ICs, tubes, semiconductors, phono cartridges and styli, even SAMS[®] manuals. We can also supply replacement batteries for cordless phones, computer memory, transceivers, pagers and more. Service is fast and there is no postage charge.



(1) **Universal Breadboard.** Our best! Molded 2 1/4 x 6 1/2" board on 7 x 4" steel base with rubber feet and three binding posts. #276-169 19.95
 (2) **Breadboard Jumper Wire Kit.** Our 140-piece set of ready-to-use hookup wires. #276-173 4.95

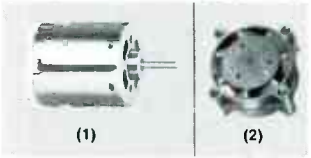

(1) **High-Speed 12VDC Motor.** Up to 15,200 RPM at no load. About 2" long (with shaft). #273-255 2.99
 (2) **12VDC Brushless Micro Fan.** For cooling mobile equipment and hum-sensitive circuits. Rated 4.6 CFM, 150 mA. #273-244 17.95

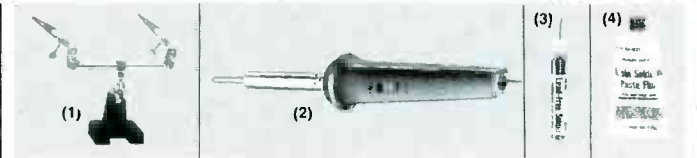

(1) **Adjustable Project Holder.** Our extra-sturdy "Helping Hands" holder simplifies soldering, gluing and assembly work. #64-2093 8.19
 (2) **Dual-Wattage Soldering Iron.** Go from 15 to 30 watts with the flick of a switch. 8 1/4" long. UL listed AC. #64-2055 9.49
 (3) **Lead-Free Solder.** Top choice for fine electronics work. 96% tin, 4% silver composition. .032"-diameter. 0.25 oz. #64-025 1.99
 (4) **Soldering Paste Flux.** #64-021 1.79

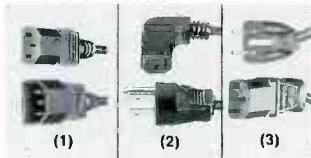

Computer/Business Machine AC Power Cords. 6 ft. HP (CEE-type) connectors. UL listed.
 (1) **Extension.** #278-1259 4.99
 (2) **90° Type.** #278-1260 5.99
 (3) **With Straight CEE Connector.** #278-1257 3.99

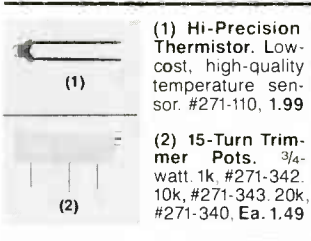

(1) **Hi-Precision Thermistor.** Low-cost, high-quality temperature sensor. #271-110, 1.99
 (2) **15-Turn Trimmer Pots.** 3/4-watt. 1k, #271-342, 10k, #271-343, 20k, #271-340, Ea. 1.49



Infrared Module. Ready-to-use module for remote-control projects. Combines an IR detector, limiter and demodulator in a compact 3-lead package. 5VDC. With data. #276-137 3.49



ENERCELL[®] Battery Guide. Complete data on all ENERCELL batteries plus basic battery information and tips to help you choose the right battery for the job. Over 230 pages. #62-1304 5.95



Mini Audio Amplifier. Perfect for use as a test-bench amp and for computer voice/music synthesis. Built-in speaker plus 1/8" headphone jack, 1/8" input jack, volume control. #277-1008, 11.95

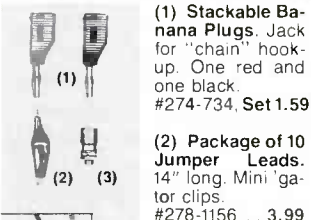

(1) **Stackable Banana Plugs.** Jack for "chain" hook-up. One red and one black. #274-734, Set 1.59
 (2) **Package of 10 Jumper Leads.** 14" long. Miniigator clips. #278-1156 3.99



Miniature Piezo Speaker. Only 13 1/32" diameter by 5/64" thin. Efficient 1200-ohm audio transducer can be directly driven by ICs. Response: 500 Hz to 20 kHz. 273-091 2.49

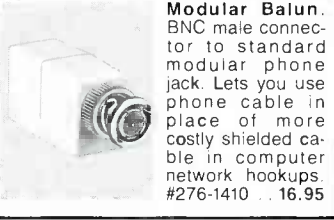

Modular Balun. BNC male connector to standard modular phone jack. Lets you use phone cable in place of more costly shielded cable in computer network hookups. #276-1410 16.95

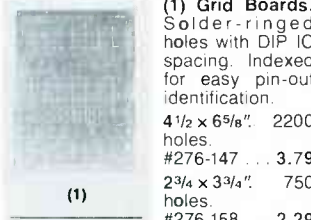

(1) **Grid Boards.** Solder-ringed holes with DIP IC spacing. Indexed for easy pin-out identification.
 4 1/2 x 6 5/8". 2200 holes. #276-147 3.79
 2 3/4 x 3 3/4". 750 holes. #276-158 2.29
 1 27/32 x 2 27/32". 356 holes. #276-149 99c

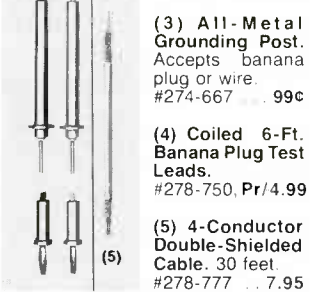

(3) **All-Metal Grounding Post.** Accepts banana plug or wire. #274-667 99c
 (4) **Coiled 6-Ft. Banana Plug Test Leads.** #278-750, Pr/4.99
 (5) **4-Conductor Double-Shielded Cable.** 30 feet. #278-777 7.95



Crimp-Style D-Sub Connectors. With quality gold-plated contacts.
 9-Position Male. #276-1427 99c
 9-Pos. Female. #276-1428 1.19
 25-Position Male. #276-1429 1.49
 25-Pos. Female. #276-1430 2.49



D-Sub Pin Crimping Tool. This professional steel tool makes it easy to install D-sub connectors. Accepts #20, #24 and #28 pins. Comfortable cushioned handles provide a firm, secure grip. 6 7/8" long. #276-1595 9.95

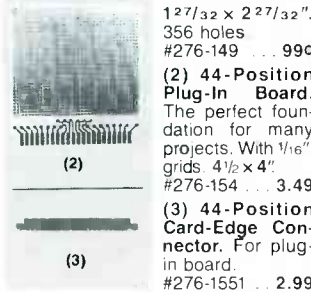

(2) **44-Position Plug-In Board.** The perfect foundation for many projects. With 1/16" grids. 4 1/2 x 4". #276-154 3.49
 (3) **44-Position Card-Edge Connector.** For plug-in board. #276-1551 2.99

Since 1921 Radio Shack has been the place to obtain up-to-date electronic parts as well as quality tools, test equipment and accessories at low prices. Over 7000 locations to serve you—NOBODY COMPARES
 Prices apply at participating Radio Shack stores and dealers. Radio Shack is a division of Tandy Corporation

Radio Shack[®]
AMERICA'S TECHNOLOGY STORESM

CIRCLE 78 ON FREE INFORMATION CARD

WHAT'S NEWS

A review of the latest happenings in electronics.

Fast-rise-time, high-power, photoconductive switch

A photoconductive semiconductor switch (PCSS), developed recently by scientists at Sandia National Laboratories (Albuquerque, NM) and demonstrated using a laser-diode array developed at the Princeton, NJ-based David Sarnoff Research Center, can very rapidly turn on high amounts of electrical power using light from a much-lower-power laser-diode array.

The gallium-arsenide solid-state device has several potential applications. Some of those include use in optically activated firesets for triggering explosives, in pulse-power systems to supply energy to compact high-power accelerators, and as a fast-rise-time switch in electromagnetic pulse (EMP) testing. The PCSS might fit the bill for the small, fast-rise-time, repetitive switch required to make ultrawideband impulse radar a reality.

The device has been shown to switch 8.5 MW of power using light from an 850-watt laser diode array. Previously, the highest power switched with a photoconductive switch



NEW YORK'S "STAR DWI" PROGRAM allows drivers, upon observing a fellow motorist driving erratically, to directly report their suspicion of drunk driving to the state police.

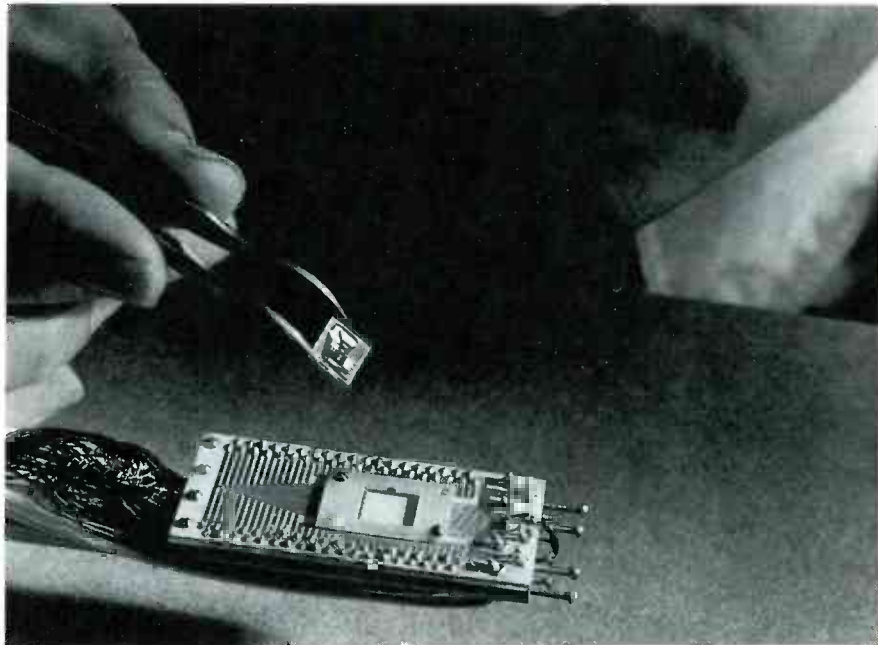

WESTINGHOUSE ELECTRIC CORPORATION SCIENTIST DONALD L. MILLER holds an IC containing a high-resolution, superconducting, analog-to-digital converter, the first operating electronic circuit of its kind. The one-square-centimeter chip, known as a counting converter, was introduced last summer. It provides high-resolution and low power consumption for use in future air-traffic-control and infrared space-tracking applications. The 12-bit circuit has a resolution of one part in 4,000.

using the same laser diode array was 0.25 MW. The new switch held off 55 kilovolts until it was activated and delivered 470 amps to a 38-ohm load. The pulse of current peaked in only 3.5 nanoseconds, even though the optical pulse that triggered the switch had a 21-ns rise time. In subsequent experiments, rise times as short as half a nanosecond have been obtained by scientists.

During the experiment, the PCSS was operating in a high-gain switching mode, called "lock-on," which allows the switch to trigger using minimal laser energy. The original experiment demonstrated the feasibility of lock-on mode in small-scale applications. Since a laser diode can emit millions of light pulses per second, future research will determine if the PCSS can switch large amounts of electrical current at high rates.

Cellular phones help battle DWI

Under a program called "STAR DWI," motorists with cellular phones

can join the New York State Police in their fight to prevent drunk driving. Motorists can report those they suspect of driving while intoxicated (DWI) directly to the state police simply by pressing the asterisk ("*") key and then the letters "D-W-I" on their cellular phones. The call is free, and is directly connected to the nearest state police communications center. The police will ask the motorist who called for the location, make, model, color, and license plate number of the suspected car and will dispatch the nearest available police vehicle to investigate.

The program, initiated in December 1990, was developed in conjunction with the state's cellular-telephone service providers, including NYNEX mobile communications. Because several other states in the northeast United States will have very similar "STAR DUI" (driving under the influence) programs, New York's cellular systems have been programmed to accept "*DUI" calls as well.

R-E

A Shocking Offer!

Now for the first time in CIE's 56 year history you do not have to be enrolled at CIE to receive our introductory Electronic and Electricity Lesson Modules. Available for a limited time to non-students for the shockingly low price of only \$149.50

With CIE's patented AUTO-PROGRAMMED method of learning you'll quickly learn and then master the basics of electronics and electricity and then move on to... DC/AC circuit theories, fundamentals of bi-polar junction transistors (BJT), field effect transistors (FET), wiring, diagram and schematic readings, component identification, soldering techniques... and much, much, more.

Your commitment to CIE ends with your payment, but CIE's commitment to your success just begins when you receive your

39 lessons, exams, binders and equipment. This special introductory price includes all the benefits and assistance CIE normally extends to its students and graduates. You'll be entitled to unlimited access to CIE's faculty and staff to assist you in your studies via a toll free 800 number six days a week, 24-hour turnaround on grading your submitted exams, CIE Bookstore privileges, a patented learning method, reference library, a student, faculty and alumni electronic bulletin board and a free issue of CIE's school newspaper The Electron. All this knowledge and support will put you on the road to understanding digital electronics, microprocessing principles, computer systems, telecommunications, and much, much, more.



**All This and Much More
For ONLY!**

\$149⁵⁰

- Free Issue of The Electron
- Build your personal burglar alarm
- Instructors available 6 days a week
- 20 lesson books containing 39 theory and hands-on training lessons and exams.

- Bookstore Privileges
- Patented Learning Method
- Electronic Bulletin Board
- 24-Hour Grading

Yes, send me CIE's 39 Introductory Electronic and Electricity Lessons and Equipment.

Name: _____

Address: _____

City: _____ Apt. #: _____

State: _____ Zip: _____

Age: _____ Phone (_____) _____

Total Merchandise: \$149.50

Ohio Residents add 7% Sales Tax: _____

California Residents add 6-1/2% Sales Tax: _____

Total this order: _____

Method of Payment: Amount Enclosed ... \$ _____

Personal Check or Money Order

Master Card Visa

Card Expiration Date: _____



BOOKSTORE

1776 East 17th Street
Cleveland, Ohio 44114
(216) 781-9400

BK03



CHARGE BY PHONE!



9 AM to 4:30 PM Eastern Time; from Ohio 1-800-523-9109
from all other states 1-800-321-2155

APRIL 1991

VIDEO NEWS

What's new in the fast-changing video industry.

DAVID LACHENBRUCH

• **HDTV Goes Digital.** It now seems fairly certain that the high-definition TV system chosen for the United States will be digital. Zenith is the latest to develop a digital transmission system, the third all-digital system to be proposed for testing by the Advanced Television Test Center. While Zenith's earlier HDTV system was the first to be partially digital (it digitized low-frequency signals), General Instrument actually proposed the first all-digital system last spring. That was followed by a second digital system, proposed by the Advanced TV Research Consortium consisting of NBC, Philips, David Sarnoff Research Center, and Thomson Consumer Electronics.

Zenith's new digital HDTV system was developed jointly with AT&T's Bell Telephone Laboratories and was said to be more compatible with digital telecommunications, computers, and interactive systems. Zenith said digital circuitry will increase the cost of receivers perhaps "a few hundred dollars" over the \$500 premium it had originally estimated HDTV sets for, because of the hybrid system standard NTSC receivers would be using.

• **Interactive Dispute.** Format battles are a fact of life in consumer electronics, and the next one probably will be in the CD-based interactive video field. Commodore Dynamic Total Vision (CDTV) system, based on the Amiga computer, apparently will be the first compact disc-based interactive system to reach the marketplace. The hardware, to be priced less than \$1,000, is scheduled to be in some stores this spring, and up to 100 software programs are promised this year. CDTV combines audio and limited-motion video with computer technology to give consumers access to such things as encyclopedias, games, atlases, and cookbooks.

But as usual, there will be competition from a non-compatible system. Compact Disc-Interactive (CD-I), sponsored by Philips, Matsushita and Sony, is the best-known interac-

tive system, but unfortunately it will require a different player and different discs from CDTV. CD-I is scheduled to hit the marketplace next fall. Like CDTV, it will provide limited video action—either half-screen full-motion or full-screen motion at half the normal TV frame rate—but Philips promises that a 1992 version will provide full-frame full-motion video. Philips promises to supply add-ones to adapt the first machines to full-motion full-frame when the new system is available, and says all programs will be "forward compatible" from the start.

There is considerable confusion as to whether the new interactive media will open up a large new field combining audio, video and books—or whether they will be just another consumer product to lay an egg. Almost certainly, we'll know the answer before 1991 is out.

• **Interchangeable Camcorder Lenses.** Four of Japan's largest camcorder manufacturers have agreed on a system of lenses for sophisticated high-end camcorders. The system can be applied to any format—VHS, VHS-C, 8mm, and Beta—and is designed for the advanced videophile or professional camcorder. It's called Video Lens (VL) and involves standard contact points on the camcorder body and lens, and microprocessors in each part of the combination, so that information on iris, exposure speed, autofocus and so on can be communicated between the lens and camcorder body.

The system was developed jointly

by Canon, Hitachi, Matsushita and Sony. The first version has been unveiled by Canon in an ultra-sophisticated high-band 8mm (Hi8) model equipped with a 15× zoom lens. Options offered are an 8× zoom lens and a 2× extender, which will double the focal length of either lens.

Because Canon is also a major manufacturer of 35mm still cameras, it's offering something extra—an adaptor which will permit the use of any autofocus lens made for its EOS single-lens reflex cameras with its camcorder. The new VL mount system will eventually permit the separate selection of camcorder bodies and lenses, mixing different brands and bringing so-called "home" video up to the sophistication level of film photography.

• **Scratch One, Add One.** Despite the softening of the television set market in the U.S. last year, the picture tube boom goes on, but there has been one deflection from the ranks of tube plant expansion. Philips, which had planned a new production facility in Saline, Michigan, abandoned the idea after the foundation had been dug, citing economic conditions. But Mitsubishi, which builds big 35-inch tubes in Japan, said it was looking for a site to build them in the United States. Thomson Consumer Electronics recently completed an expansion of its Indiana plant to make 35- and 31-inch tubes. Other new and expanded tube plants were completed or started in the U.S. last year by Matsushita, Toshiba, Hitachi and Sony. **R-E**



CANON'S NEW 8mm camcorder with interchangeable lenses.

NTE KEEPS YOU UP AND RUNNING.

NTE specializes in "replacitivity," the science of getting things up and running again—fast! After all, downtime is costly, so no one can wait weeks on end for an OEM part to come in. With NTE, no one has to! One call gives you access to 3,550 top of the line universal replacement semiconductors that are cross-referenced to more than 240,000 original devices! Included in the NTE line are: bipolar transistors, integrated circuits, rectifiers, diodes, thyristors, optoelectronic devices, varistors, resistors, capacitors, and much, much more. All are backed by NTE's exclusive two-year warranty.

For your copy of the NTE Technical Guide contact your local NTE distributor, or simply fill in the coupon below and send it to us today with a check or money order for \$3.25 each.



NTE ELECTRONICS, INC.

A WORLDWIDE REPUTATION FOR QUALITY, SERVICE AND VALUE

Please rush me _____ copies of the NTE Technical Guide and Cross Reference manual at \$3.25 each. I have enclosed my check or money order for a total of \$ _____

Name _____

Company _____

Address _____

City _____

State _____ Zip _____

Mail to: NTE, 44-T Farrand St., Bloomfield, NJ 07003



For the name of your nearest NTE distributor, call NTE: Toll Free: 1-800-631-1250 (incl. Canada)

Tel: (201) 748-5089 • FAX: (201) 748-6224

CIRCLE 71 ON FREE INFORMATION CARD

What's your

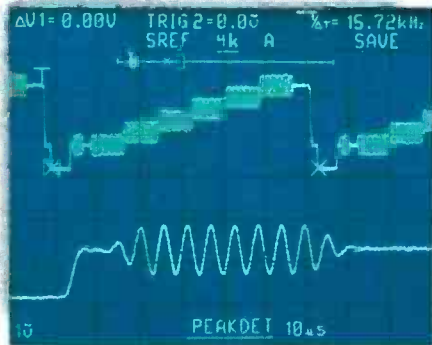

Analyzing TV and complex video signals?

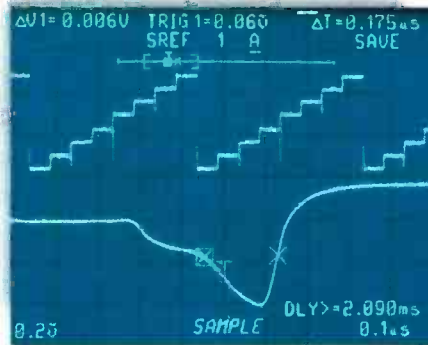

Uncovering elusive glitches?

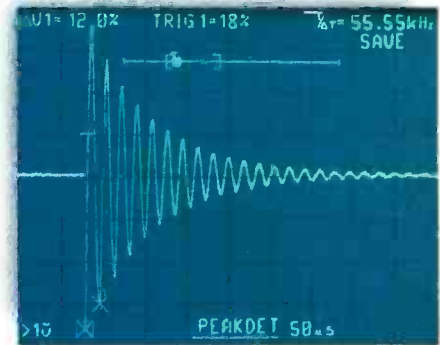

Capturing single-shot events?

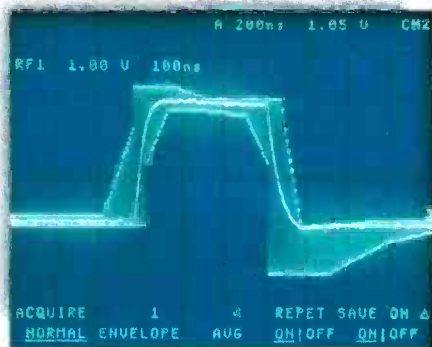

Testing telecommunications signals?



Finding aberrations buried within a signal?

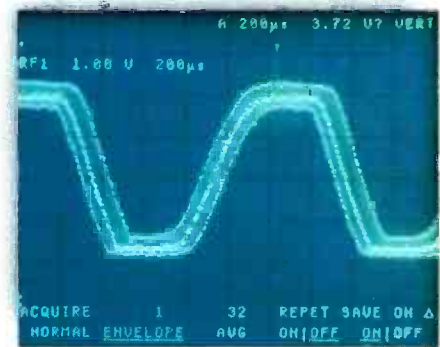

Automatic PASS/FAIL testing?

You can't depend on banner specs alone to solve problems like these.

Whether you're trying to measure waveform parameters or analyze long data streams, identify infrequent events or track down glitches as narrow as 2 ns — there's all the difference between the depth of Tek troubleshooting and the trade-offs in other DSOs that compromise your results.

Spec for spec, feature for feature, no other company offers the credentials Tek does to

effectively match DSO performance to your application needs. Whatever your criteria, you'll find a perfect solution in our line of problem-solving portable DSOs, from 10 to 500 MS/s.

Select the features to support your application. Tek DSOs offer a diverse set of capabilities including peak detect to uncover elusive glitches. Fast update rate for live signal display. Combined analog/digital operation for real-time verification of your

r problem?

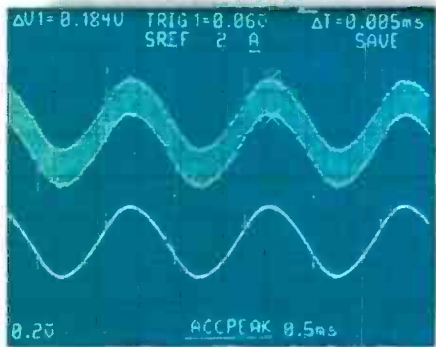

Characterizing signal noise?

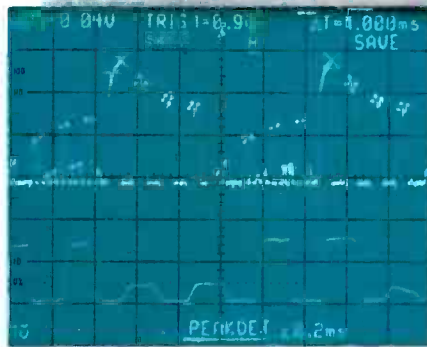

Capturing and analyzing long data streams?

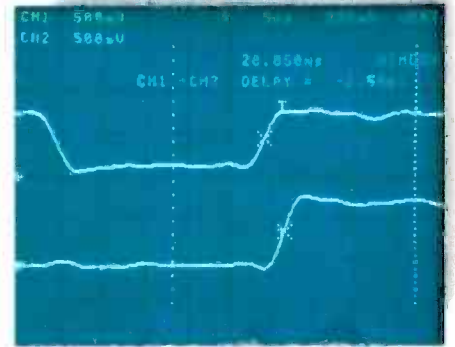

Measuring timing relationship between signals?

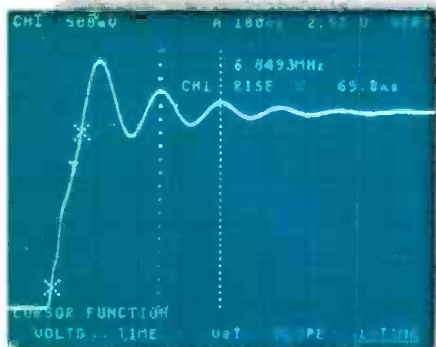

Performing complex measurements automatically?

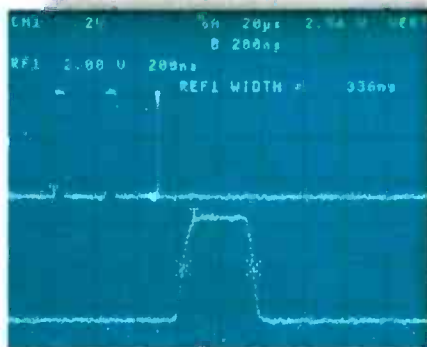

Expanding glitches for close analysis?

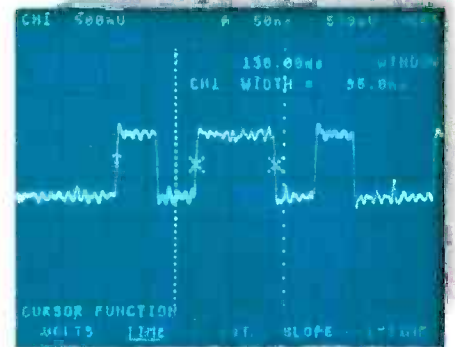

Windowing in on signal details?

signal. Or Save on Delta to automatically verify that all parts of your signal fall within prescribed limits. Best of all, Tek's line of 100 MS/s digitizing scopes start at just \$3995.

To find out which Tek scope is right for you, contact your Tek representative, return the card or call Tek direct. We can answer your questions and show you a scope that doesn't just look good on paper. It makes your toughest troubleshooting challenges routine.

1-800-426-2200



One company measures up.

Tektronix
COMMITTED TO EXCELLENCE

CIRCLE 92 ON FREE INFORMATION CARD

ASK R-E

Write to Ask R-E, Radio-Electronics, 500-B Bi-County Blvd., Farmingdale, NY 11735

WIND-SPEED READ

I recently built a 2-digit LED counter using a 7490 decade counter and a 7447 display driver. I want to use it for an anemometer but I don't know what to use to make the display read up and down as the wind speed changes. Any ideas?—L. Fiedler, Garden Grove, CA

You haven't sent me the schematic or block diagram for the circuit you want to build, so I'm not sure exactly what you have in mind. There are, however, a few things you can try.

The most straightforward thing to do is to replace the 7490 with a 74190. That counter is similar to the one you're using, but it can count both up and down. The count direction is determined by putting either a low or a high on the DOWN/UP pin (pin 5). A low will make the 74190 count up and a high will make it count down. A pinout diagram of the 74190 is shown in Fig. 1.

Since the chip can only handle a maximum count of ten, you might consider using two of them cascaded together. That would give you a maximum count of 99 and, should the wind speed exceed that, the circuit will more than likely be the least of your worries.

The 74192 is another up/down decade counter that can be used in your circuit. It has the advantage of a master clear input and is a bit easier to use when you want to cascade two chips to increase the counting range.

Both the 74190 and the 74192 are cheap and available so it's a good idea to get a few of each to experiment with. You're going to have to come up with a way to control the signal on the direction pin but, since you're using a mechanical anemometer, there are several mechanical ways to get the job done.

Get yourself a data book and do some brain stretching exercises at the test bench. The design problems you have in front of you are interesting ones and you should have a good time working out the right solution.

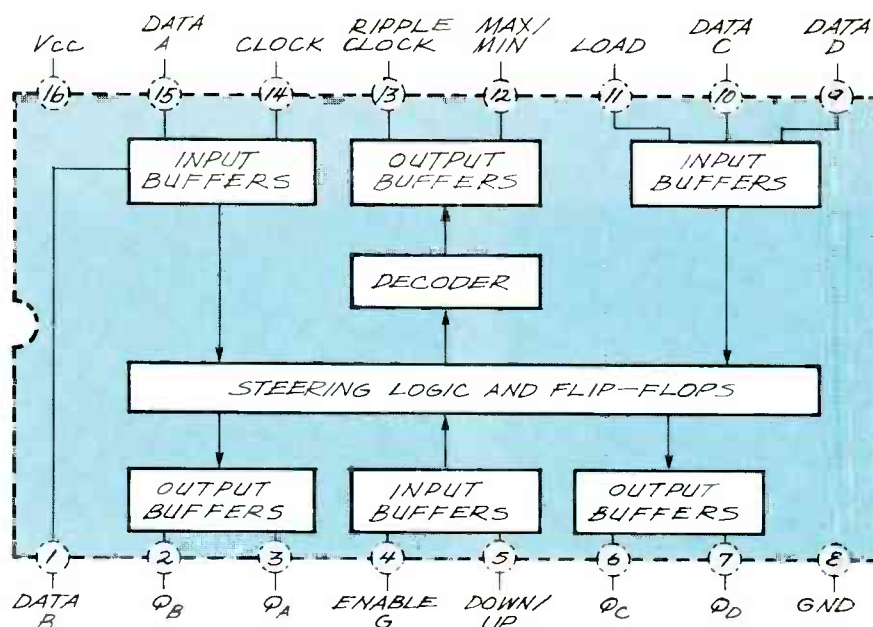

FIG. 1—THE 74190 CAN COUNT both up and down. The count direction is determined by putting either a low or a high on pin 5. A low will make the 74190 count up and a high will make it count down.

FLYBACK SQUEAL

I'm just getting started in electronics and I'm having trouble with a minor repair problem. The flyback transformer in a TV always gives off an annoying squeal and I need some way to eliminate the noise or at least drop it to a more tolerable level. I don't have access to a lot of parts, and money is also a problem. Is there anything at all you can suggest?—L. Leduc, Abbotsford, Canada

Before we get started, let me tell you that, as far as I'm concerned, transformer squeal is one of the world's most annoying sounds.

The only absolutely sure way to solve the problem is to replace the transformer. There's no way to take the old one apart. Every time I've tried to quiet a transformer without actually changing it, I've only managed to make the sound go away for a short while. It always comes back.

If there's no way you can replace the transformer, there are some other things you can do. I've done all of

them at one time or another.

Before you even think of doing anything to the transformer, pull the plug and properly discharge all capacitors to ground. And don't forget that even wood can serve as a conductor for high voltages. That's a long way of saying that you can still get a nasty
continued on page 76

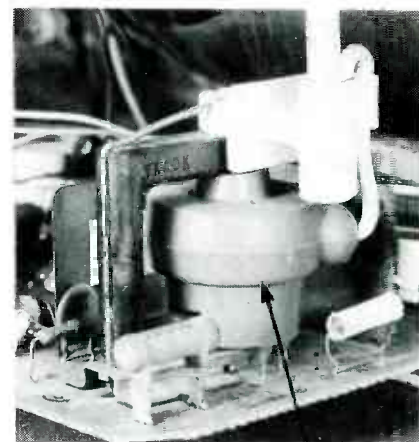

FLYBACK

FIG. 2—TYPICAL FLYBACK transformer. You can try to eliminate the squealing noise, or at least cut it down a bit, by covering the transformer with RTV high-voltage putty or hot-melt glue.

LETTERS

Write to Letters, Radio-Electronics, 500-B Bi-County Blvd., Farmingdale, NY 11735

AMIGA AMIGO

I could not help but feel a bit disappointed when I read *Computer Connections* in the January issue of **Radio-Electronics**. The author, Jeff Holtzman, speculates on the future of personal computers, predicting: (1) a (preemptive) multitasking operating system; (2) an NTSC-compatible video system; I/O subsystems based on coprocessors; a graphical operating environment (with command-line mode for power users); and multimedia.

Gee! That's funny! The Amiga's been doing all that for five years! You mean... MS-DOS machines *might* have all that in the *future*? Wow, that's great! Then they'll only be *ten* years behind!

Perhaps the column's name should be changed to "MS-DOS Connections." The current title is misleading, because a reader might mistakenly

think that the column provides an unbiased look at computer technology. Of course, in the October 1990 issue of **Radio-Electronics**, Mr. Holtzman calls himself a "PC chauvinist." Oh, I see—that makes it OK to ignore the rest of the computer world!

What I'd love to see is more Amiga coverage. Mr. Holtzman may be a PC chauvinist, but I'm a hot-blooded Amiga evangelist from the bowels of Hell. (Amiga—it's not just a computer, it's a religion!)

He could at least *mention* my favorite machine, couldn't he? Surely nobody could have such a severe case of tunnel vision.

But, alas, this letter is undoubtedly in vain. Nobody pays attention to us Amiga users... but thanks for reading this far!

By the way, my original letter was typeset blazingly fast on a bottom-of-

the-line Amiga 500, with AmigaT_EX, of course. You know what they say—"The best way to accelerate an MS-DOS machine is at 32 m/s²" (Larry Phillips).

RAYMOND CHENG

Mississauga, Ontario, Canada

Jeff Holtzman's response appears in this month's *Computer Connections*.—Editor.

MAC-HACK ATTACK

Thank you for the information on hacking a Macintosh ("Build Your Own Macintosh-Compatible Computer," **Radio-Electronics**, January 1990). I've been doing that kind of idiocy for a while, but believe me, it's not worth it. Add it up:

Clone case	\$ 90.00
Fujitsu 800K floppy drive	104.00
Mouse (Samurai)	50.00
Monitor	50.00
Video/sync processor	59.00

PUT THE PC10 IN YOUR PC FOR MORE COUNTER POWER.

OPTOELECTRONICS does it again - phenomenal power, performance and price.

This is what sets our PC Based Universal Counter apart from any other counter available on the market today...

- Instant Direct Tune - Set a communications receiver such as ICOM R7000 to frequency detected by counter. Patent pending.
- Data logging and data file creation to keep records or measure frequency drift.
- Menu selection for Units includes CPM/RPM, Hz, KHz, MHz, GHz, Sec, mS, uS and nS.
- Software timebase calibration of 1ppm TCXO timebase.

- Windows 3.0 operating environment with fully developed operating and signal conditioning controls accessible through pull down menus.

In addition to these unique features, PC10 is a down right high performance counter...

- 10 digit 10Hz to 2.4GHz frequency range.
- Measurement Period (Gate Time) continuously variable from 1 milli-second to 28 seconds.
- Reciprocal Counting for high resolution measurement.
- Input sensitivity is less than 10mV from 10Hz to over 1.6GHz.
- Direct count frequencies over 200MHz with 1Hz resolution in 1 sec.

Model PC10 Universal Counter Timer Board for the PC. Introductory Price \$339.

The PC10 has on board 50 ohm RF input with amplifiers and prescalers to operate as a stand alone 1MHz to 2.4GHz RF counter. TTL level input signals can be connected directly to the miniature 25 pin D connector on the mounting bracket. For low frequency, high impedance inputs, the Model AP10H companion amplifier must be used.

Model AP10H Dual High Impedance Amplifier Head Unit (not shown). Introductory Price \$299.

The AP10H is the companion head unit that supports all PC10 Universal Counter functions from 10Hz to 100MHz with 1 megohm inputs. Input attenuators, low pass filters and trigger levels are software selectable.

Options: TCXO 10 Precision Temperature Compensated Time Base \$195. ±0.2ppm 20°-40°C. 1ppm - year aging.

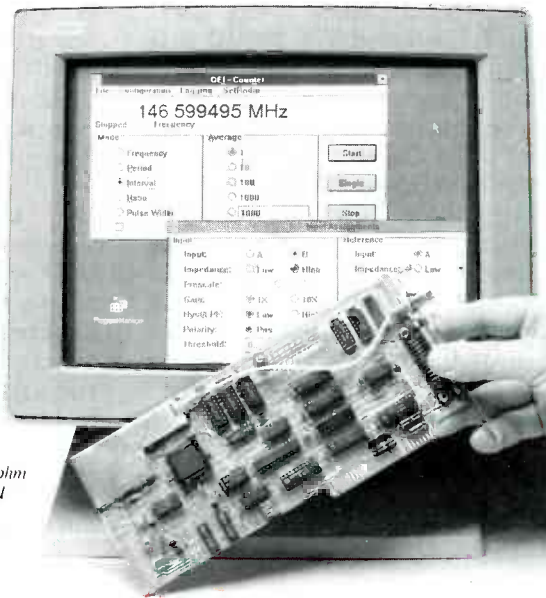

OPTOELECTRONICS

Toll Free Order Line: 1-800-327-5912
FL (305) 771-2050 • FAX (305) 771-2052
5821 NE 14th Avenue • Fort Lauderdale, Florida 33334



CIRCLE 183 ON FREE INFORMATION CARD

Assorted cables	30.00
Fan	8.00
Memory/SCSI board	150.00
New ROM's	100.00
Motherboard	50.00
Used keyboard	50.00
Power supply	13.00
AC filter	3.00
Power cord	1.00
Battery	4.50
2 Meg RAM	80.00
Your time (10 hours at least)	250.00
TOTAL	\$1092.50

You might as well go out and buy a packaged Mac from a dealer, because the above expenditures give you a bare-bones 8-MHz unit with a dinky screen and no hard disk!

ALEX FUNK
Durham, NC

MORE ON MACINTOSH BUILDING

I read with interest the article "Build A Macintosh-Compatible Computer" (**Radio-Electronics**, January 1991). Having purchased a Mac 128K in 1984 and upgrading the 128K motherboard (I'm still using it) to its current 2-MB RAM, 128K ROM, and SCSI drives, I noticed a few critical points that were overlooked. I hope this letter will help clear up some issues that could cause problems for your readers.

First, not every Mac is compatible with all software! Software written for the Mac II (68020 CPU) will not run on a Mac 128K, 512K, Plus, etc. There are a lot of programs that are written for System 6.0.x and these programs will *not* run on a Mac with the older 64K ROM. It is very difficult to find *any* software that will run on a 128K Mac today! You really must have the 128K ROM and 512K of RAM to use most Mac software.

Second, there is a significant difference between a 128K and 512K motherboards that have the 128K ROM's added along with more RAM and the Mac Plus motherboard. Those early motherboards had 20 bytes of Parameter RAM (battery backed). From the Mac Plus on, Apple used 256 bytes of parameter RAM called XPRAM. Under System 6.0.x, the sound and Map Control Panel programs will not work unless you have the 256 bytes of XPRAM. The term "512KE" is often used to identify 512K, 64K ROM motherboards that have been upgraded with 128K ROM, which is not correct. Apple issued 512KE motherboards that

had 128K ROM and 256 bytes of parameter RAM, and those are the true "512KE" motherboards.

I have found a simple solution to the XPRAM problem. My motherboard has only 20 bytes of parameter RAM but I am using a System 6.0.x with no problems. I am using Scott Armitage's XPRAM INIT software that uses disk space to replace XPRAM memory. Best of all, the software is free (you can download it from GENie) and it works great!

Finally, on page 36 of the article it said that with 64K ROM you can use only 400K floppy drives, yet the parts list on page 32 states that you can use an 800K floppy with a 128K or a 512K motherboard. That is confusing, but there is a solution. You *can* use an 800K floppy-disk drive with a motherboard that has 64K ROM *only* if you have Apple's Hard Drive 20 system file in the system folder. That file was intended for Apple's original hard drive that plugged into the floppy-disk-drive port and worked with the 512K machines. It also lets you use 800K floppies. The file is available on GENie.

In case your readers don't have access to GENie, for \$5 and a formatted blank disk, I will send them the XPRAM and Hard Drive 20 files (\$7 without a disk). (No phone calls after 9:30 PM CST, please.)

There are a number of vendors out there with products for making your own Macintosh and upgrading older 128K and 512K motherboards that were omitted from your article. Less Hall (P.O. Box 5732, Raleigh, NC 27650) supplies Macintosh parts and information; Atlanta Technical Specialists (3550 Clarkston Ind. Blvd., Suite F, Clarkston, GA 30021) sells cases, video cards, and kits; motherboard upgrades, SIMMS and SCSI, can be obtained from both Computer Care (Ford Center, Suite 1180, 420 North Fifth Street, Minneapolis, MN 55401) and Newbridge Microsystems, 603 March Rd., Kanata, Ontario, Canada K2K 2M5; Soft Solutions (907 River Road, Suite #98, Eugene, OR 97404) provides Macintosh parts and repairs; and Maya Computer (1-800-541-2318) offers Macintosh motherboards and all kinds of parts.

ANTHONY J. ORESTEEN
452 Orion Road
Batavia, IL 60510
(708) 879-5608

A RAVE REVIEW

Just a brief note to let you know that Robert W. Ramirez's article, "Putting a New Scope to Work" (**Radio-Electronics**, January 1991), was one of the best I have ever read. It was explicit and well planned, and written in clear and concise English. Thanks for a great article.

SIDNEY GOLDBER
San Leandro, CA

FAX-MATE FIX-UP

It has been brought to our attention that the "Fax-Mate" project (**Radio-Electronics**, October 1990) has an unwanted switching problem to the fax mode for some speech situations. A closer study of the schematics showed that the Silicon Systems' DTMF decoder (IC2, SSI 204) is used incorrectly. Please advise your readers of the correct implementation of the Silicon Systems' DTMF decoder IC.

As reflected in the device's data sheet, the detected DTMF digit (pins 14, 13, 1, and 2) are guaranteed valid when the Data Valid (pin 12) is high. The author of the project has not used the DV pin. One way to correct the problem is to use a 3-input AND gate (74LS11) instead of IC3-a and connect the DV pin to it.

Another problem with the circuit is a phenomenon called "talk off," which is defined as detection of the DTMF tone in the presence of speech. As the human voice does include the frequencies of DTMF tones, a false detection is inevitable. One method to prevent this is to use two DTMF tone sequences instead of one. For instance, a two-digit code of "11" would reduce the false detection problems.

RENA MOATTAR
Senior Applications Engineer
Silicon Systems Inc.
Tustin, CA

LCD MODULE UPDATE

I enjoyed very much the articles on LCD modules that appeared in the June and July 1990 issues of **Radio-Electronics**. I can find fault with only one aspect, which I have also seen perpetuated elsewhere. The problem is with the idea of using fixed delays after each operation on the LCD.

The idea of performing an operation on a device, then waiting for a fixed delay in software for the device

Cable TV

Descrambler Article Parts

We stock the exact Parts for several articles published in Radio-Electronics magazine on building your own Cable TV Descrambler.

February 1984 SB-3 Type

701 Parts Pkg.....\$19.00
Includes all original parts.

702 PC Board.....7.95
Original 3X4 etched, drilled and Silk-Screen pc board.

704 AC Adaptor.....7.95
12 to 18 Volt DC @ 200ma.

701, 702 & 704.....29.00
All three for special saving.

February 1987 Tri-Mode

301 Parts Pkg.....29.00
Includes all original parts.

302 PC Board.....7.95
Original 5X8 etched, drilled and Silk-Screen pc board.

304 AC Adaptor.....7.95
12 to 18 Volt DC @ 200ma.

301, 302 & 304.....39.00
All three for special savings.

Tri-Mode Tutorial..7.95
26 pages of in-depth info.

May 1990 Universal

901 Parts Pkg.....\$49.00
Includes all

902 PC Board.....9.95
Improved 4X7 etched, drilled and Silk-Screened pc board.

904 AC Adaptor.....8.95
12 to 18 Volts AC @ 350ma.

901, 902 & 904.....59.00
All three for special savings.

Snooper Stopper...\$39.00

Prevent Descrambler detection with snooper stopper/data blocker and protect your privacy. Includes free article on Cable Snooping.

Macrovision Kit...\$29.00

Macrovision.....now you see it, now you don't with our macro-scrubber kit. Originally Published in Radio-Electronics .

Signal Eliminator (tunable notch filters).....\$29.95

*Model number & channel; #23 (channel 2 & 3) #46FM (channel 4 to 6 & FM)
#713 (channel 7 to 13) #1417 (channel 14 to 17) #1822 (channel 18 to 22)*

1 remote replaces 3...

The MAC 20 wireless remotes replaces any three combinations; TV, VCR, Cable Converter, Stereo, CD or other entertainment system.

MAC 20.....\$59.95

A VCR in every room..

with the first FCC approved wireless home broadcast system. 120 ft. range.

VC2000.....\$99.95

70 Channel Cable TV Converter.....\$89.95

- * 6 Function Infra-Red remote. * Compatible with all External Descramblers.
- * Fine Tuning. * Channel 3 or 4 switchable output.
- * Memory & Recall. * STD, HRC & IRC compatible.

CALL TOLL FREE 1-800-332-3557

Outside USA Call 1-508-699-6935

Visa, MasterCard and COD.

Add \$4.00 S&H, \$6.50 Outside USA.

D & D Electronics, Inc. PO Box 3310, N. Attleboro, Ma. 02761

VISA

MC

CIRCLE 185 ON FREE INFORMATION CARD

LISTING 1

```

DISLET BCLR 0, PORTB      ENABLE OFF
      BSET 1, PORTB      SET R/W TO READ
      BCLR 2, PORTB      SET RS=0
      BSET 0, PORTB      ENABLE ON
BRSET 7, PORTA, DISLET  BUSY?-LOOP
BCLR 0, PORTB      ENABLE OFF
BCLR 1, PORTB      SET R/W TO WRITE
BSET 2, PORTB      SET RS=1
STA PORTA          OUTPUT CHAR
LDA #$FF          REVERSE DATA LINES
STA DDRA          (DATA DIRECTION REGISTER FOR PORTA)
BSET 0, PORTB      ENABLE ON
BCLR 0, PORTB      ENABLE OFF
CLR DDRA          DISABLE DATA LINES
RTS
    
```

to finish, is always a very poor one. First of all, there is always some processing to do before you use the device again, and possibly the device will have finished by the time you get back to it, thereby making the delay unnecessary. Furthermore, the exact question of time delays gets more complicated. Are the figures on the specifications sheet average times or worst-case times? What if the device gets replaced with a slower one, or the clock rate of the processor gets changed. What if, as in the LCD, the

device takes a long time to power up?

The best solution, specifically for the LCD, is to use the busy flag provided to you by reading the MSB of the data with RS = 0. That can always be read in the basic cycle time of the LCD (approximately 1 μ s). Depending on your hardware, that might require some changes to make the data bus bidirectional.

The software would, before each LCD operation, check the busy flag and loop until it was clear, then go ahead with the operation. That would

take care of the power-up delay and the variable delays associated with different operations. If you wanted to be extra careful, you could make the software timeout after 100 ms, so that the processor would not "hang" if the LCD was disconnected or broken.

Listing 1 (and, similarly, Listing 2) of the June article could be rewritten as shown here:

Good luck!
 RUSS HOBBS
 Worcester, MA

THEFT OF CABLE SERVICES

In the July 1990 issue of **Radio-Electronics**, in his *Drawing Board* column, Robert Grossblatt defended the theft of cable TV pay services on philosophical grounds that are apparently shared by those who write to your *Letters* column. That philosophy is also shared by the "phone phreaks" and power-meter bypassers who have spent time in jail for their beliefs. Those people are no less thieves than those who drive off from a gas station without paying.

It is fortunate that the majority of the population does not subscribe to that philosophy. The honest majority must pay higher prices for their goods and services to subsidize those who choose not to pay. If everyone stole all services, the services would cease to exist.

I believe that a magazine that publishes material describing methods and equipment clearly intended to defraud legitimate businesses is as guilty as the authors who write and the readers who use that material. If a magazine must resort to that sort of sensationalism to boost readership, perhaps another line of business is indicated.

JIM SPENCER
 Fern Park, FL

TELEPHONE LINE CONTROLLER

I've received so many questions concerning my article "Telephone Line Controller" (**Radio-Electronics**, September 1990) that I've put together a "Question-and-Answer" flyer. It answers the most commonly asked questions, and is available at no charge by writing to AC&C, 717 East Jericho Turnpike, Suite 101, Huntington Station, NY 11746.

MORDECHAI SAAD

R-E

For quality, cost-effective test instruments.

B&K-PRECISION is your one-stop source!

Our line includes digital and analog oscilloscopes, multi-meters, frequency counters, power supplies, generators, digital and IC testers, semiconductor and other component testers. They all offer famous B&K-PRECISION quality, plus immediate delivery from a distributor near you.

FREE BUYING GUIDE

For a 68-page guide with detailed specifications on all our products, contact your local distributor or:



Domestic and International Sales
 6470 W. Cortland St., Chicago, IL 60635
 312-889-1448 • FAX: 312-794-9740
 Canadian Sales, Atlas Electronics, Ontario



CIRCLE 77 ON FREE INFORMATION CARD

Build your own laser printer at a fraction of the cost of those expensive store-bought units.

PAUL RENTON

A LASER PRINTER CAN REALLY ADD that extra touch to your printouts. The superb graphics resolution gives your printouts a professional look, and the fast text output (8 pages per minute) can really speed up your printing. Although laser-printer prices have dropped drastically in the last few years, they are still a little too expensive for the average person. However, you can now build your own laser printer at home and save thousands of dollars!

How it works

Laser printers are essentially souped-up copy machines. They

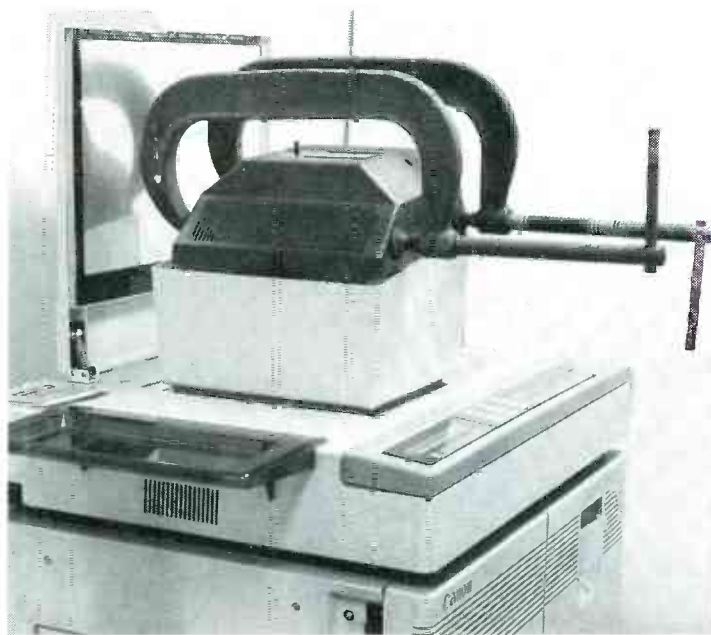

FIG. 1—THE MONITOR CAN BE SECURED to the copier surface using C clamps, superglue, or even large rubber bands. The exact method you use depends on your particular copier/monitor combination.

use a photosensitive drum which is exposed to a laser beam. The laser beam can be turned on and off while spinning mirrors sweep the laser beam across the drum selectively discharging it. Toner

is transferred to the drum in the charged places and then onto paper to produce the final image.

Since a copy machine already has the paper feed, the photosensitive drum...
continued on page 84

**POOR MAN'S
LASER PRINTER**

Add comfort, convenience, fun to your home with these innovative electronics.

Hundreds of easy innovations.

Your home will do more for you with Heath products. Simple to install. Affordable. Guaranteed.

Play a tape on the living room VCR and watch it on your bedroom TV.

Turn on and adjust your TV, VCR, music system, lamps, fans and more with just one remote control.

Plug in an extra phone jack without messy cutting and drilling.

Get a complete home status report via phone from anywhere in the world. (If the electricity goes off, this electronic "house sitter" calls you.)

Automatically water your lawn at a fraction of the cost of a built-in system.

Call home and turn on your lights, appliances ... even a window air conditioner.

Affordable security for your home or car.

Protect your home or car with a professional-quality security system for as little as \$100.

Program lights to go on or off, so your home looks lived-in when you're away.



**HOME
AUTOMATION
BY HEATH**

Never again return to a dark house. Motion sensor lighting turns on your outdoor lights as soon as you approach.

100% satisfaction ... the Heath guarantee for over 40 years.

Try any Heath product at no risk. If you aren't completely satisfied, simply return the item within six months for credit or full refund.

Get your FREE CATALOG.

Heath's new Home Automation catalog features the latest in home control. For over 100 ways to make your home comfortable and convenient, call **1-800-44-HEATH** or send the coupon below.

Heath
Benton Harbor, Michigan

Please send me the NEW Home Automation catalog.

Name _____
Address _____
_____ Apt. _____
City _____
State _____ Zip _____

Mail to Heath Company, Dept. 020-040,
Benton Harbor, MI 49022

11A-100

CIRCLE 86 ON FREE INFORMATION CARD

EQUIPMENT REPORTS

Hewlett Packard 54601A Portable Digital Oscilloscope

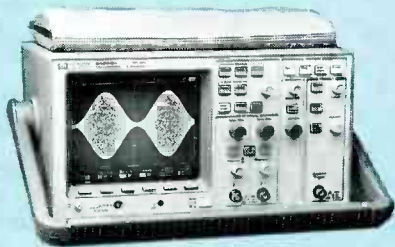

CIRCLE 10 ON FREE INFORMATION CARD

A full-featured DSO at a competitive price.

As weary as test-equipment manufacturers are of battling the competition—which comes from both on- and off-shore—they continue to wage a valiant fight. And we continue to be the beneficiaries. The latest examples of the trend are two new scopes from Hewlett Packard (1900 Garden of the Gods Road, Colorado Springs, CO 80907-3483): the two-channel HP 54600 and its 4-channel sister, the 54601A.

Both of the scopes (we examined the 54601A) feature a 100-MHz bandwidth with a sampling rate of 20 megasamples per second (8-bit storage). Vertical sensitivities range from 2 mV/div to 5 V/div (on the first two channels; the third and fourth offer sensitivities of 0.1 and 0.5 V/div). The timebase can range from 2 ns/div–5 s/div. Because they are digital, they offer a number of other features that are inherent benefits of DSO's. Since these scopes are targeted at technicians and engineers who may never have purchased a digital scope, we'll review some of those benefits.

Why digital?

The first benefit, of course, is the ability to store waveforms. The 54601A has two trace memories, which can store two complete sets of waveforms; that is, each set can contain signals from all four channels. Unlike analog storage scopes, the signals can be retained indefinitely in memory, so measurements made in

the field can be viewed later.

Traces on digital scopes can be easier to view, and thus they can be more informative. Low-frequency signals will remain steady and bright instead of flashing. Signals with low repetition rates will be displayed at the same brightness as any other signal. Transients can be captured without the need for a scope camera, and signals that occur *before* a trigger can be viewed.

Digital oscilloscopes have the reputation of being difficult for an analog-scope user to adjust to. However, that's not the case here. The front panel offers a clean layout that is easy to use even for those used to analog scopes. The only main-panel controls that aren't normally found on analog scopes are the RUN, STOP, AUTOSTORE and ERASE buttons for trace storage, and the TRACE and SETUP store/recall buttons.

The rest of the controls are equally scarce—or so they seem. The main panel can be kept so open and easy to use because most functions are controlled by six "soft key" pushbuttons below the CRT. Those keys take on the functions as displayed above the keys. For example, when the CHANNEL 1 button is pressed on the main panel, the soft keys below the CRT let you select the input coupling, signal inversion, etc.

Using the scope

A push of a single button can set the scope up even if you don't know

what signal you are expecting to view. Alternatively, if you routinely perform certain measurements again and again, you can store up to sixteen complete front-panel setups in memory.

Interpreting the signals shown on the CRT can be extremely easy. The voltage, (peak-to-peak, average, and rms value), frequency, period, and duty cycle of the signals on each channel can be displayed automatically. On-screen cursors can be moved manually to make voltage and time measurements.

The display-update time is quite fast, and gives the scope the feel that you'd expect from an analog scope. One of the reasons for that is that Hewlett Packard uses custom acquisition-processor and display-processor IC's that don't rely on the scope's CPU to handle data acquisition or display management.

Do all these features make the scope easier to use? We have to answer, "Yes, definitely." Because we were examining an early prototype (the scopes won't be available for almost two months as we write this report, but will be available when you read it) we didn't have an opportunity to examine an operating manual—not even a preliminary draft. Nonetheless, we encountered no problems that we weren't able to answer with a bit of experimentation.

Optional interfaces (which we didn't examine) can increase the versatility of the 54601A. Serial RS-232, parallel, and HP-IB (IEEE-488) interfaces can provide hardcopy output to plotters and printers. Optional software allows you to easily convert waveforms into popular MS-DOS graphics and data formats. In addition, the scope is fully programmable via the serial and HP-IB interfaces.

The HP 54600A and 54601A 100-MHz digital oscilloscopes aren't the lowest priced or the most fully featured 100-MHz DSO's on the market. However, with prices of \$2395 and \$2895, they are a bargain that will be hard to resist for engineers and technicians involved in everything from R&D to field service. **R-E**

Start a money-making career in video/audio servicing!

Only NRI gets you started fast with real-world training designed around state-of-the-art equipment you keep!

NRI's newly expanded training covers all the latest advances in home entertainment electronics, then takes you inside today's high-tech equipment as you learn to troubleshoot, diagnose, and service the complete home entertainment system included in your course: 13" color TV, programmable VCR, and integrated audio rack system. Only NRI makes it so easy to start a new career, earn part-time income, even start a video/audio servicing business of your own!

Billions of dollars of video/audio equipment means big opportunity for you

There's never been a better time to get involved in home entertainment electronics. Experts predict that consumers of video/audio equipment will spend over \$26 billion by 1995 as product manufacturers race to fill the demand for increasingly sophisticated technology.

This explosive acceleration of new product innovation means new opportunities for you in video/audio servicing. And NRI prepares you to take advantage of those opportunities by giving you the skills to troubleshoot and service a full range of TV, video, and audio equipment.

The most advanced, most complete video/audio training ever offered!

You start with lessons that give you a strong foundation in electronics fundamentals, mastering the basic circuits and components at the heart of today's video/audio equipment.

Then you build on that foundation as you explore the high technology of digital controls, CDs and digital audio tape players, advanced TV systems, cable TV, VCRs and camcorders, even microprocessors.

Best of all, you're prepared for the technology of today and tomorrow with hands-on training designed to give you invaluable practical experience.

Hands-on training with this incredible array of home entertainment equipment gives you the skills you need for success.



State-of-the-art equipment included in your training makes theory come to life

Only NRI gives you so much real-world equipment ... all yours to train with and keep! Get hands-on experience as you work with a complete, high-tech home entertainment system: a 13" color TV with remote, a programmable VCR, and an integrated remote-controlled audio system including AM/FM tuner, 100 watt amplifier, CD player, dual cassette player, turntable, speakers, and audio rack cabinet.

Theory comes to life as you learn to perform component-level diagnosis and service on advanced technology audio equipment ... conduct in-set demonstrations of TV circuits and components ... and discover first-hand how to maintain and service today's commercial VCRs.

Plus, NRI custom-produced videos

show you in close-up detail how to test, troubleshoot, and service TVs and VCRs like a pro.

No experience necessary ... NRI builds it in

You need no previous experience in electronics to succeed with NRI. Step by step, you accumulate the knowledge and practical experience that will make you uniquely qualified for today's opportunities in home entertainment electronics.

You learn at your own pace and on your own time. And all throughout your training, you have the full support of your personal NRI instructor and the entire NRI technical staff.

FREE catalog tells more

If the coupon is missing, write to NRI Schools, McGraw-Hill Continuing Education Center, 4401 Connecticut Avenue, NW, Washington, DC 20008.

SEND TODAY FOR FREE NRI CATALOG

NRI Schools

McGraw-Hill Continuing Education Center
4401 Connecticut Avenue, NW, Washington, DC 20008

Check one FREE catalog only

- TV/Video/Audio Servicing
- Microcomputer Servicing
- Computer Programming
- Telecommunications
- PC Systems Analysis
- PC Software Engineering Using C

For Career Opportunities approved under GI Bill
 check for details

- Desktop Publishing & Design
- Electronic Music Technology
- Word Processing Home Business
- Automotive Servicing
- Basic Electronics
- Bookkeeping & Accounting

Name _____ (Please print) _____ Age _____

Address _____

City _____ State _____ Zip _____

3-041

NEW PRODUCTS

Use the Free Information Card for more details on these products.

MONOSCOPE/TV PATTERN GENERATOR.

Designed for testing the higher-resolution large-screen television sets, *Leader Instruments' model 435B* generates monoscope patterns with a resolution of 1000 lines, as well as color bars, crosshatch, pulse and bar, and character patterns. Color bars can be superimposed on the monoscope pattern to check resolution and color simultaneously. The instrument includes RF out for evaluating TV and VCR circuits. Frequency response can be evaluated with the line-sweep signal, and transient response can be checked with the window pattern. A five-step staircase is provided for lu-

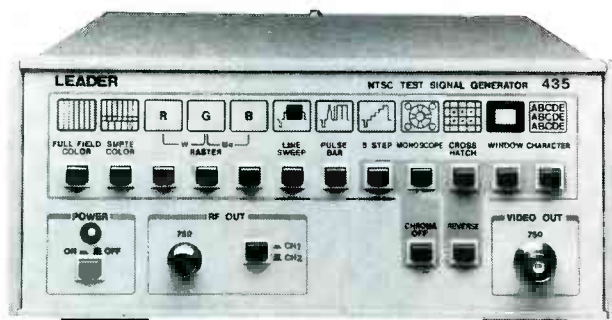

CIRCLE 16 ON FREE INFORMATION CARD

minance linearity, and a 1.5-kHz signal is provided for evaluation of audio. The model 435B pattern generator offers a total of 21 patterns, including two types of color bars, five rasters, line sweep, and five-step staircase. It can evaluate high-voltage stability and

character reproduction as well as linearity.

The model 435B TV pattern generator costs \$3,100.00—**Leader Instruments Corporation**, 380 Oser Avenue, Hauppauge, NY 11788; Tel: 1-800-645-5104 (in NY, 516-231-6900).

logic-shutdown pin, which allows the unit to be toggled on and off to conserve energy, is especially convenient.

The model 48S5.5000XW DC/DC converter has a list price of \$160.00.—**CALEX Mfg. Co., Inc.**, 3355 Vincent Road, Pleasant Hill, CA 94523; Tel: 800-542-3355; Fax: 514-932-6017.

ESD-SAFE SMT VACUUM PICK-UP PENCIL.

For safely handling static-sensitive surface-mount components, *OK Industries' VP-150 Series* vacuum pick-up pencil is uniquely designed and manufactured using static-dissipative materials. The tool allows manual-placement users to handle SMT IC's without worrying about static discharge.

The VP-150 provides two user-selectable vacuum-deactivation modes. A two-position switch allows for both "continuous" vacuum operation, in which vacuum deactivation is achieved when the user lifts his finger off the handpiece's bleed-hole, and "foot-pedal" operation, in which the vacuum is deactivated electrically by pressing a foot pedal. The vacuum pick-up pencil can be used with *OK Industries' SMT-810* board holder and *SMT-815* component carousel.

The VP-150 vacuum pick-up pencil has a suggested list price of \$176.00.—**OK Industries, Inc.**, 4 Executive Plaza, Yonkers, NY 10701; Tel: 914-969-6800.

FOUR-IN-ONE INSTRUMENT.

Combining a 100-MHz frequency counter, a 2-MHz function generator, an auto-ranging digital multimeter, and a 0-50VDC/0-2A power supply in one compact case, *Bel MERIT's MT-100* provides a cost-effective way to acquire a comprehensive test laboratory that won't crowd a workbench. The MT-100 is designed for use in education, production lines, hobby electronics, inspection work, or design engineering.

The MT-100 frequency counter/function generator/DMM/power supply has a

suggested list price of \$595.00.—**Bel MERIT Corporation**, 14775 Carmentia Road, Norwalk, CA 90650; Tel: 213-802-3666; Fax: 213-802-3298.

DC/DC CONVERTER. With its wide input range of 20 to 72 volts DC, *Calex's model 48S5.5000XW* DC-to-DC converter eliminates the need for separate converters for different voltage requirements within that range. The unit can be used for either 24-volt or 48-volt powered systems, and is designed for use in a wide variety of industrial control systems.

The model 48S5.5000XW provides an output of 5 amps at 5 volts DC with an 80% efficiency, with switching technology used to regulate the output voltage. Key specifications are 0.05% line and load regulation; 10 mV peak-to-peak output noise; and -25



CIRCLE 18 ON FREE INFORMATION CARD

to +80°C operating temperature range.

The converter has input-to-output isolation of 500 volts. Internal transient suppressor devices guard the input and output against high-voltage spikes. Filters provide protection against conducted noise from both the input and the output, the shielded case provides RFI protection, and the unit is also short-circuit protected. The output voltage can be trimmed $\pm 10\%$ with a potentiometer, voltage source, or DAC. For remote battery or solar-powered applications, a

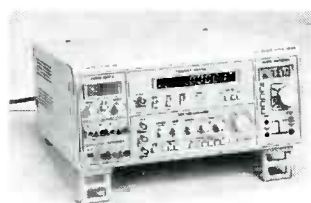

CIRCLE 17 ON FREE INFORMATION CARD



CIRCLE 19 ON FREE INFORMATION CARD

SELECT 5 BOOKS for only \$4.95

(values to \$127.70)

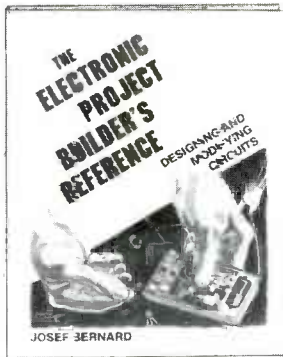
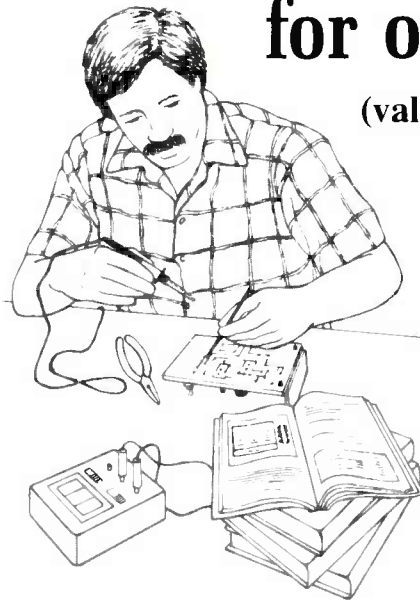

3260 \$22.95

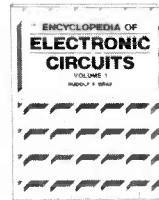

1938 \$60.00
Counts as 3



2867P \$18.95



10010P \$19.95



3321P \$16.95

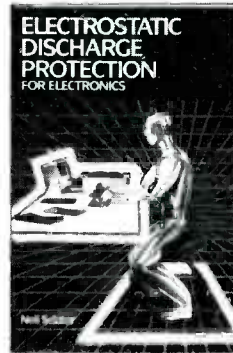

3329 \$29.95
Counts as 2



2987P \$16.95



3360 \$29.95
Counts as 2

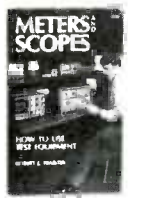

2826P \$16.95



3279 \$36.95
Counts as 2



3445 \$21.95



2995 \$25.95

Your most complete source for electronics books for over 25 years.



3031P \$17.95

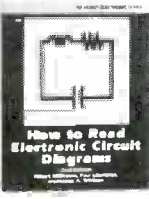

2881P \$14.95



3258 \$27.95
Counts as 2



3107P \$18.95



2865P \$14.95



3219 \$27.95
Counts as 2

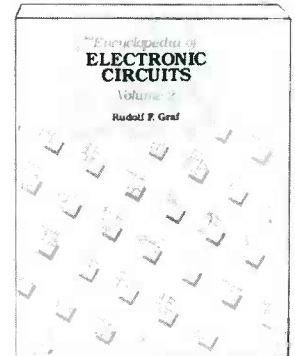

3138 \$60.00
Counts as 3

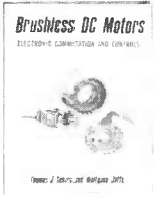

3267P \$16.95



3342 \$25.95
Counts as 2

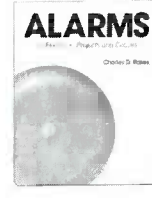

2996P \$13.95

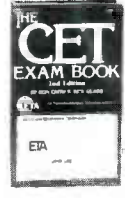

2950P \$13.95



3205 \$24.95



2707P \$17.95



3270 \$32.95
Counts as 2

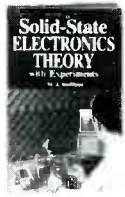

2926 \$25.95

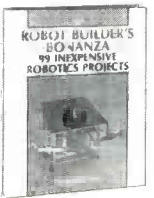

2800P \$16.95



2613P \$17.95



1897P \$15.95



2883P \$17.95

Membership Benefits • Big Savings. In addition to this introductory offer, you keep saving substantially with members' prices of up to 50% off the publishers' prices. • **Bonus Books.** Starting immediately, you will be eligible for our Bonus Book Plan, with savings of up to 80% off publishers' prices. • **Club News Bulletins.** 15 times per year you will receive the Book Club News, describing all the current selections—mains, alternates, extras—plus bonus offers and special sales, with scores of titles to choose from. • **Automatic Order.** If you want the Main Selection, do nothing and it will be sent to you automatically. If you prefer another selection, or no book at all, simply indicate your choice on the reply form provided. You will have at least 10 days to decide. As a member, you agree to purchase at least 3 books within the next 12 months and may resign at any time thereafter. • **Ironclad No-Risk Guarantee.** If not satisfied with your books, return them within 10 days without obligation! • **Exceptional Quality.** All books are quality publishers' editions especially selected by our Editorial Board.



ELECTRONICS BOOK CLUB

Blue Ridge Summit, PA 17294-0810

Please accept my membership in the Electronics Book Club and send the 5 volumes listed below, billing me \$4.95. If not satisfied, I may return the books within ten days without obligation and have my membership cancelled. I agree to purchase at least 3 books at regular Club prices during the next 12 months and may resign any time thereafter. A shipping/handling charge and sales tax will be added to all orders.

--	--	--	--

Name _____

Address _____

City _____

State _____ Zip _____ Phone _____

Valid for new members only. Foreign applicants will receive special ordering instructions. Canada must remit in U.S. currency. This order subject to acceptance by the Electronics Book Club. RPIE491

All books are hardcover unless number is followed by a "P" for paperback

(Publishers' Prices Shown)
©1991 ELECTRONICS BOOK CLUB

VOLT-OHM-AMMETER. A.W. Sperry's *Digisnap DSA-7610A* 3½-digit, snap-around volt-ohm-ammeter is designed to live up to heavy-duty use in portable electrical-service applications. The compact, battery-operated instrument measures AC voltage (0–500V), AC current (0–300A), and resistance (0–2K ohms). It provides auto-ranging, an instant audible



CIRCLE 20 ON FREE INFORMATION CARD

continuity buzzer, and an automatic power-off feature. Other features include safety-styled test leads, recessed safety-designed input jacks, current transformer jaws that open simultaneously, electronic overload protection, and a data-hold switch. One set of test leads, two batteries, and a carrying case are included with the instrument.

The *Digisnap DSA-7610A* volt-ohm-ammeter costs \$119.95.—**A.W. Sperry Instruments, Inc.**, 245 Marcus Boulevard, Hauppauge, NY 11788; Tel: 516-231-7050.

PRECISION MONOLITHIC ±10V REFERENCE. *Analog Device's AD688*, claims to be the industry's first precision monolithic ±10V reference, has a maximum tracking error of 1.5 mV, initial error of 2.0 mV, and a temperature drift of only 1.5 ppm/°C. The device's absolute accuracy performance matches that available

from expensive, complex hybrid devices. Its performance is achieved by laser-trimming high-stability, thin-film resistors to correct for

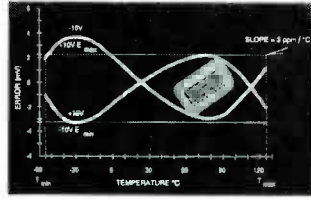

CIRCLE 21 ON FREE INFORMATION CARD

drift. Applications include robotic, avionic, and instrumentation designs, as well as 12- to 16-bit data-acquisition systems.

The *AD688* offers 12-bit absolute accuracy without any user adjustments or trims. For extremely precise applications, the reference can be calibrated using the "gain" and "balance adjust" pins. Force and sense connections (Kelvin connections) are used to correct for the effects of voltage drops in circuit wires by forcing the reference output of the device to a value that precisely compensates for the voltage error.

The reference cell consists of an ion-implanted buried Zener diode and three low-drift amplifiers that facilitate Kelvin connections. It is packaged in a machine-insertable, 16-pin cerdip with three grades specified by accuracy and temperature range. The *AD688AQ* is specified over the –40 to +85°C industrial temperature range and the *AD688SQ* over the –55 to +125°C range. Both of those precision references have an initial output error of ±5 mV and a tracking error of ±3 mV. The *AD688BQ* is specified over the –40 to 85°C temperature range with an initial error of ±2 mV and a ±1.5-mV tracking error.

The *AD688 ±10V* reference is priced starting at \$12.75 in hundreds.—**Analog Devices, Inc.**, Applications Assistance, 181 Ballardvale Street, Wilmington, MA 01887; Tel: 617-837-1428.

DIGITAL MULTIMETER. Offering high-performance and easy operation, *Global Specialties' model 735* 3½-digit LCD-readout multimeter with autoranging capability is suitable for professionals, schools, and hobbyists. Its measurement functions include DC and AC voltage, DC and AC current up to 10 amps, resistance, diode check, and continuity check. Advanced features include data hold, which provides hands-free operation by retaining the last measurement value even after the test probes have been removed from the circuit, and memory mode, which allows



CIRCLE 22 ON FREE INFORMATION CARD

deviations and relative measurements to be made by subtracting the latest measurement from the stored value.

The model 735 DMM costs \$59.95.—**Global Specialties**, 70 Fulton Terrace, New Haven, CT 06512; Tel: 1-800-572-1028.

PORTABLE IBM PS/2. For those who require desktop power, storage, and expandability in a laptop computer, the *IBM Personal System/2 model P75 486*, based on Micro Channel architecture, features a 33-MHz i486 microprocessor and comes standard with either a 160-MB or a 400-MB fixed-disk drive. The portable computer has a 10-inch gas plasma display and VGA resolution, 8 MB (expan-

dable to 16 MB) of high-speed (70 ns) memory, and a full 101-key PC keyboard.

The *P75 486's* integrated design makes it easily expandable. It offers an external small computer system interface (SCSI) port and an external video port of IBM's extended graphics array (XGA) video subsystem, both integrated on the system

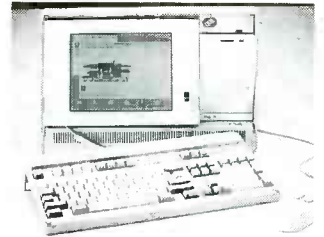

CIRCLE 23 ON FREE INFORMATION CARD

board. Users can connect to a variety of SCSI peripherals and support for 1024 × 768 resolution on an external monitor without using any of the system's two full-size (32-bit) and two half-size (16-bit) expansion slots. The system is supported by OS/2 Extended and Standard Editions 1.2 and 1.3, DOS 3.3 and higher, and DOS with Microsoft Windows 3.0. Some of the available options include a molded-plastic travel case with wheels that fits under airplane seats or in overhead luggage compartments.

The *P75 486* costs \$15,990 for the 160-MB hard-drive version and \$18,890 for the 400-MB version.—**IBM Corporation**, US Marketing & Services, 1133 Westchester Avenue, White Plains, NY 10604.

THERMISTOR/COMPUTER INTERFACE MODULES. Offering a combination of wide-range analog input-signal conditioning, analog-to-digital conversion, and on-off control features, *DGH Corporation's D145/1452* modules make it easy to link 2252-ohm thermistors to any computer with a serial port. They communicate in ASCII over an RS-232C or RS-485 link, using an 8-bit CMOS micro-

computer to perform all scaling, linearization, and calibration tasks. That eliminates the need for potentiometers, switches, or any kind of adjustment hardware. The single-channel data-acquisition modules also eliminate multiplexing problems, by putting the hardware at the input source. As many as 124 modules can be strung on a single set of wires.

The measurement temperature range is 0 to 100°C, measurement resolution is 0.01°C or F, and accuracy is $\pm 0.1^\circ\text{C}$ (25° ambient). The conversion rate is 8/s, and input isolation is 500V rms. Communication features include channel address, 300 to 38.4K baud rate, parity, line feed, byte-time delays, echo, and checksum. Communications setups are stored in nonvolatile memory to prevent accidental erasure. The thermistor/computer interface modules are packaged in 3.6 x 2.45 x 0.85-inch

and fine voltage controls also provided.

The compact bench-top instrument has 0.01% regulation and less than 1-mV RMS ripple, and is conservatively rated for continuous operation and maximum power output without overheating. Designed to withstand accidental abuse, the power supply is equipped with reverse-polarity



CIRCLE 25 ON FREE INFORMATION CARD

protection from an external DC source, overload protection, thermal protection, short-circuit protection, and current limiting.

The model 1611 provides fully isolated positive and negative outputs, so either polarity can be floated or grounded. It offers both constant-voltage and constant-current operation, with automatic mode selection. In constant-voltage applications, a current limit can be preset. If variations in the load cause the current to reach the present value, the unit automatically switches to constant-current operation. Two 1611 units can be connected in parallel to double the current output, or in series to double the voltage output.

The model 1611 power supply, that comes complete with hook-up leads, spare fuse, parts list, schematic diagram, and instruction manual, has a suggested retail price of \$295.00.—**B&K-PRECISION**, 6470 West Cortland Street, Chicago, IL 60635; Tel: 312-889-1448. **R-E**



CIRCLE 24 ON FREE INFORMATION CARD

cases with captive hardware and a plug-in screw terminal connector.

The $D^{1451/452}$ thermistor/computer interface modules cost \$250.00 in single quantities.—**DGH Corporation**, P.O. Box 5638, Manchester, NH 03108; Tel: 603-622-0452; Fax: 603-622-0487.

POWER SUPPLY. With two analog meters, the model 1611 0-50-volt, 2-amp DC power supply from **B&K-Precision** provides simultaneous monitoring of voltage and current output. For precise output settings, two current ranges are selectable, with coarse

CABLE - TV

SIGNAL REMOVERS

- FOR ELIMINATION OF SEVERE INTERFERENCE
- FOR "CENSORING" OF ADULT BROADCASTS



FOR FULL DESCRIPTION OF USES ask for our free brochure

- ATTENUATION - 45 dB TYPICAL
- BANDWIDTH - 4 MHz AT 5 dB POINTS
- INSERTION LOSS - 2 dB

MODEL	TUNING RANGE	FOR CHANNELS	PASSBAND	PRICE	SHIPPING
23H	50-66 MHz	2,3 (or 6 meter ham)	50-300 MHz	\$30	NO SHIPPING OF C.O.D. CHARGES
46FM	66-108 MHz	4,5,6 (or any FM)	50-300 MHz	\$30	
1417	120-144 MHz	14(A) 15(B) 16 (C) 17(D)	50-400 MHz	\$30	
1822	144-174 MHz	18(E) 19(F) 20(G) 21(H) 22 (I)	50-400 MHz	\$30	
713	174-216 MHz	7,8,9,10,11,12,13	50-400 MHz	\$30	

3 for \$75 - 10 for \$200 - mix or match

CALL TOLL FREE FOR C.O.D. OR SEND CHECK TO ORDER
FAST DELIVERY
30 DAY MONEY BACK GUARANTEE (3 FILTER LIMIT)

Star Circuits

P. O. Box 94917
Las Vegas, NV 89193-4917

1-800-433-6319

CRAMOLIN® DeOxidizer

IMPROVES CONDUCTIVITY

DEOXIDIZES • CLEANS • PRESERVES • LUBRICATES

For All Metals, Including Gold!

CRAMOLIN® DeOxidizer improves conductivity by dissolving oxides that form on metal connector and contact surfaces, eliminating unwanted resistance that impedes electrical performance.

CRAMOLIN® is an active ingredient that does not rely on solvents for performance. Due to the excellent migration properties, CRAMOLIN® coats the entire metal surface and protects it from future oxidation.

CRAMOLIN® continues to be the most effective and economical product for improving and maintaining electrical component reliability.

FOR MANUFACTURE, MAINTENANCE AND SERVICE OF:

- Switches & Relays • Cable Connectors & Adaptors
- Edge Connectors • Terminal Strips • Plugs & Sockets
- Gold Plated Connectors • Potentiometers • Battery Contacts

USED BY THOSE WHO DEMAND THE BEST:

- Bell & Howell • Capital Records • Dolby Laboratories
- Hewlett Packard • John Fluke Mfg. • McIntosh Labs
- MCI (Sony) • Motorola • NASA • Nakamichi
- RCA • Switchcraft • and Many More.

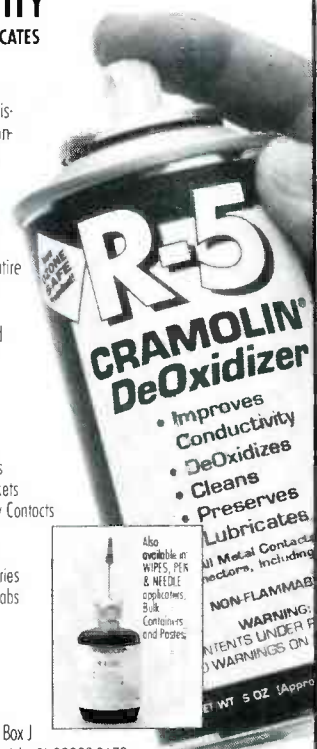

Since 1956
CAIG
LABORATORIES, INC.
"Environmentally Conscious"

P.O. Box 1
Escondido, CA 92033-3679
(619) 743-7143
FAX: (619) 743-2460

CIRCLE 50 ON FREE INFORMATION CARD

NEW LIT

Use The Free Information Card for fast response.

GREAT RADIO READS CATALOG #5; from Tiare Publications, P.O. Box 493, Lake Geneva, WI 53147; Tel: 414-248-4845; \$1.00.

Expanded to 20 pages, this catalog features a wide variety of books and other items designed to help you get more out of your radio hobby—whether you're into SWL, ham, scanning,

GREAT RADIO READS

The New Tiare Catalog is filled with a wide variety of books and other items to help you get more out of your radio hobby, whether you're an SWL, ham operator, scanner fan or CB'er.

We've greatly expanded our catalog to bring you books and other information designed to a wide variety of radio interests and related items.

New books from Tiare include Coast Guard Radio, The Variable Frequency and the Radio Communications Software Directory.

We hope you find something in here of interest and we check to appreciate the opportunity to serve you!

Tiare Publications
P.O. Box 493
Lake Geneva, WI 53147

Catalog #5 - \$1.00

CIRCLE 27 ON FREE INFORMATION CARD

or CB's. New books include *Coast Guard Radio* and *Radio Communications Software Directory*. Besides books, the catalog offers items such as SWL forms, software, globes and maps, and even a "Radio for Peace" T-shirt.

HDTV: ADVANCED TELEVISION FOR THE 1990's; by K. Blair Benson and Donald G. Fink. McGraw-Hill Book Company, 11 West 19th Street, New York, NY 10011; Tel. 1-800-2-MCGRAW; \$39.95 (hardcover).

The advent of high-definition television has created dozens of questions for which America's high-technology industries must

find reliable, realistic answers. This book strives to answer such questions as: Which of the HDTV systems now being developed will become the standard? How can broadcasters take part in HDTV? Will consumers be willing to pay the price for improved performance? What effect will recent FCC rulings have on HDTV development?

The book features technical overviews of the various competing HDTV and ATV (advanced TV) systems currently under development—including a detailed analysis of Zenith's spectrum-compatible system—and carefully assesses the strengths and weaknesses of each. It examines all aspects of the 1125-line system, from its equipment and colorimetric standards, to transmission and modulation considerations, and methods for coping with noise

discussion of pertinent management issues that must be resolved is included. The book also provides a practical look at techniques for simulcasting, receiver design specifications, the distribution and transmission of the picture signal, and the impact of HDTV technology on program production.

TMT-1 TRANSMISSION MEDIUM TESTER; from Beckman Industrial, 3883 Ruffin Road, San Diego, CA 92123-1898; Tel: 619-495-3200; Fax: 619-268-0172; free.

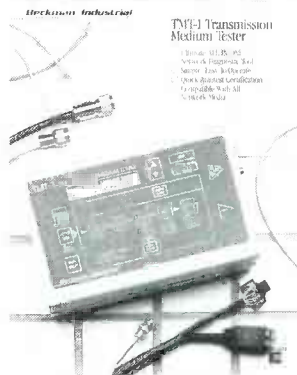

CIRCLE 29 ON FREE INFORMATION CARD

This six-page, full-color brochure describes Beckman's TMT-1 transmission medium tester, an instrument used in local area networks (LAN's) certification. The TMT-1 is a lightweight portable instrument designed to verify the capability of installed LAN's to conduct high-reliability information traffic. The brochure explains the series of tests performed by the TMT-1 either automatically or under manual control. The literature is free from Beckman upon request.

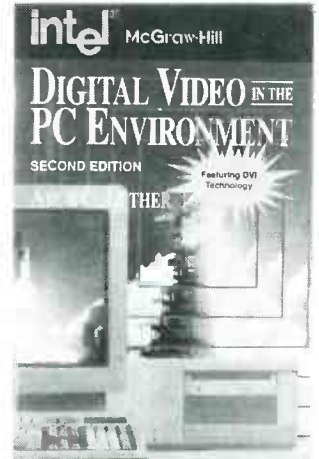

CIRCLE 30 ON FREE INFORMATION CARD

DIGITAL VIDEO IN THE PC ENVIRONMENT; Second Edition; by Arch C. Luther. McGraw-Hill Book Company, 11 West 19th Street, New York, NY 10011; Tel. 1-800-2-MCGRAW; \$29.95.

Digital Video Interactive, or DVI, technology is an exciting new field that brings together audio, video, and personal computers to create a system with vast storage capacity that is user friendly and can deliver multimedia presentations. This book is written for those who are interested in learning about DVI and the special skills required for practical applications of the technology.

The second edition has been fully revised and updated, and includes a thorough examination of the i750, an inexpensive DVI chip from Intel that promises to make DVI technology economically feasible for a wide range of PC applications. Also covered are the latest writable and erasable optical storage media, and new C language software. **R-E**

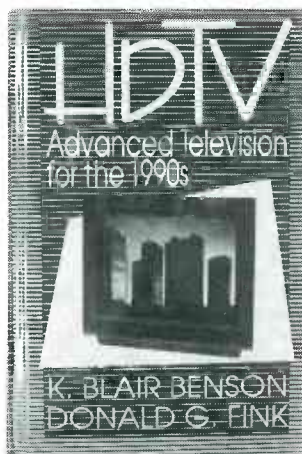

CIRCLE 28 ON FREE INFORMATION CARD

and other problems. The book explores a wide range of topics, including signal compression, digitization, fiber-optical tests, and tape recording. An in-depth dis-

FCC APPROVES NO-CODE

A codeless Amateur Radio license class has just been granted by the FCC!

MIKE STONE WB0QCD

IF YOU'VE EVER THOUGHT ABOUT GETTING an Amateur Radio license, but shied away from it because of the Morse code test, here's your chance. For the first time in U.S. Amateur Radio Service history, it will be possible to obtain a Technician class Amateur Radio license without passing a Morse code test.

The Federal Communications Commission (FCC) Docket number 90-55, passed on December 13, 1990, eliminates the 5 word-per-minute (WPM) prerequisite for the new Technician class license. The relaxed requirements for the Technician license will take effect February 1, 1991.

The FCC took this action in response to numerous petitions and public comments. Among the organizations who petitioned the FCC was the American Radio Relay League (ARRL). They believe the codeless Technician license will open the door to Amateur Radio for qualified persons who find the international Morse code for continuous wave (CW) telegraphy to be a barrier. At a press conference held shortly after the Commission's meeting, the FCC's Private Radio Bureau Chief Ralph Haller W4RH said "The Amateur Service is not growing as it should relative to what it has to offer." The FCC believes that passing Docket 90-55 will keep the U.S. at the forefront of communications research and development, and help to recruit new qualified people into the Amateur Radio Service.

In addition to the above, the FCC has also passed Docket 90-356, which will affect licensing requirements for handicapped individuals. The high-speed CW code test will now be waived for some handicapped individuals if their physical condition makes it impossible to learn the

code at the required speeds. A physicians certificate will be required to determine eligibility of this waiver.

FCC license grades

There are currently five levels of FCC Amateur "Ham" Radio license grades, in ascending order: Technician, Novice, General, Advanced, and Extra. Each grade of license carries with it specific operating privileges and assigned frequency areas in which the user may transmit signals over-the-air. Presently, Amateur Radio license grade requirements include:

- Technician—No Morse code, a 55-question test is required involving electronics and radio theory operation.
- Novice—5-WPM CW.
- General—13-WPM CW.
- Advanced—13-WPM CW.
- Extra—20-WPM CW.

All license grades require a written theory test. The Novice and Technician written tests are the same. The General, Advanced, and Extra written exams get increasingly difficult.

Privileges for the new Technician-grade license are 30 MHz and above with all mode, voice and repeater privileges. That includes the 50-MHz, 6-Meter band (in which worldwide DX is possible), the popular 2-Meter band (144-148 MHz), which features local FM simplex, repeater, satellite, radio teletype and packet or computer activity. The 222 to 224-MHz, 420 to 450 MHz (voice, satellite and ATV), 900- and 1200-MHz bands and above are also included within the operating privileges of the Technicians license.

The present Novice class category grants CW and limited "voice talk" privileges on 28-MHz worldwide open HF bands which can be obtained by passing a 5 WPM-code exam and theory test.



The General, Advanced and Extra class licenses offer unrestricted "talk" and mode HF privileges as well as more frequency space.

The recruit for radio hobbyists

Ham Radio has lost quite a number of significant pioneers who first began hobby operations back in the 1920's and 30's. Many of those "true" Hams began tinkering with radio, TV and electronics as kids in their teens and early twenties which now puts them well into their seventies and eighties. All Hams mourn the loss of those talented individuals, many of whom actually changed the world as we know it today with their innovations, inventions and spirit.

Currently, there are approximately 495,166 Ham-radio license holders in the U.S. As of 1990, the number of operators by license class are:

- Technician—104,771
- Novice—53,219
- General—119,393
- Advanced—126,050
- Extra—91,733

The American Ham Radio community has been making serious efforts to recruit new members since about 1980. Amateur Radio has captured the interest and licensed many young people within its ranks. Yet, we need *more new* increased active numbers to sustain the operating frequencies that the FCC has granted us. We also realize that we want to be selective in those that we want to bring into our fraternal ranks.

Amateur Radio hobbyists are interested in attracting a clientele of technically qualified electronic hobbyists that, as a group, will contribute and advance the hobby even further. With a little help and guidance, those people would make excellent additions to the overall Ham Radio com-

munity. **Radio Electronics** readers are just such a targeted after group. Now's your chance to join us!

Getting to know Ham Radio

The fastest way to get acquainted with Ham Radio is to subscribe to some of the industry's best publications. By far, the largest Ham organization in the country is the (ARRL). They have been around a long time and have a vast organization set up to help interested or new Hams. AARL has many publications about nearly every facet of the hobby. They also publish the most widely read Ham monthly publication *QST magazine*. Call or write for more information. (The names and addresses of all organizations and publications we mention are listed in the accompanying sidebar.)

Other recommended Ham Radio publications include *73 Amateur Radio Today*, published monthly at \$24.97 per year and *CQ Magazine*, published monthly at \$22.95 per year. *CQ* also has a 1991 *Amateur Radio Equipment Buyers Guide* of more than 1,000 Ham products, and a separate *Antenna Buyers Guide*, both priced at \$4.95 each, \$6.00 foreign. *Worldradio* is published monthly at \$13.00 per year.

Spec-Com is a specialized Ham Radio-based technical publication that's available for those interested in fast- and slow-scan television, facsimile, radioteletype (Baudot, ASCII and AMTOR), packet radio, Orbiting Satellite Carrying Amateur Radio (OSCAR), space and TVRO communications, lasers, microwave and computers. (The new Technician-grade codeless Amateur Radio license now allows those mode-operating privileges!)

Spec-Com supports a growing USATVS national ham-TV organization and sponsors one of the best dedicated Ham Radio computer telephone landline BBS's in the country. The *Spec-Com Journal* is published bi-monthly, at \$20.00 per year in the U.S.; \$25.00 per year in Canada and Mexico; \$30.00 foreign. A special ½ year trial subscription is available for just \$10.00 (3 issues).

A good source of available amateur equipment is contained in

the *Amateur Electronic Supply* catalog. FCC testing and study materials can be obtained from either the ARRL or the W5YI Group. Ham Radio computer software for the Radio Shack TRS80 color computer, IBM, Commodore, Apple, AmIGA, and other systems is available from *Ham Radio Software*. Ask for their current catalog and state the type of computer you own.

A special multi-page "Get Acquainted with Ham Radio" package of useful information is

available to **Radio Electronics** readers for just \$5.00. Include three 25-cent postage stamps to help with return mailing. This package offers money-saving values, listings of Amateur Radio dealers and equipment suppliers, other trade magazine sources, frequency-operating charts, dedicated Ham Radio computer BBS's around the country and a full report on the new FCC Docket 90-55 codeless license! You can order from *Amateur Radio Data Systems & Research*.

The 1991 Dayton Hamvention

If you've ever been to a "ham-fest", you know it's like a gigantic flea market of new and used surplus goodies with talks and lectures and, yes, FCC license testing. There are hundreds around the country held each year. The biggest grand-daddy of them all is coming up the last weekend in April!

The Dayton, Ohio Hamvention draws nearly 30,000 Hams from all over the world. There are many good forums you can attend for free, covering just about all facets of the Ham Radio hobby. If you do attend, be sure to stop by the Ramada Inn North (I70/I75 Little Creek road exit) on either Friday or Saturday night. Spec-Com Communications & Publishing Group, Ltd. will be holding its 6th annual Ham-TV Workshops there. On Friday April 26, the entire evening will be devoted to "Early Radio & TV" nostalgia, with actual scanning-disk demonstrations and equipment. Several speakers are lined up to reminisce about the good old days. This will be a real treat if you're an Antique Wireless collector or hobbyist as well. Saturday nights session covers ATV and WEFAX image systems.

Information on the Dayton Hamvention will be in the "Get Acquainted with Ham Radio" package mentioned earlier. If you're in the area that weekend, come over and say hello!

We hope this good news motivates many of you to take full advantage of such a rare opportunity! Amateur Radio is an interesting, educational and fun hobby. The FCC has now relaxed their rules, so go for it before they change their mind!

R-E

NAMES AND NUMBERS

The American Radio Relay League (ARRL)

225 Main St.—Dept. RE
Newington, CT 06111
(203) 665-0161
BBS: (203) 665-0161

73 Amateur Radio Today

Wayne Green Enterprises
WGE Center—Dept. RE
Hancock, NH 03449
1-800-289-0388
Colorado: (303) 447-9330

CQ Magazine

CQ Communications, Inc.
76 North Broadway—Dept. RE
Hicksville, NY 11801
(516) 681-2922

Worldradio

Worldradio Inc.
201 Lathrop Way, Ste. D—Dept. RE
Sacramento, CA 95815
(916) 457-3655

The Spec-Com Journal

Spec-Com Communications & Publishing Group, Ltd.
P.O. Box 1002—RE
Dubuque, IA 52004
(319) 557-8791
Electronic Cottage Computer BBS:
(319) 582-3235
(300-2400 baud at 8-N-1)

Amateur Electronic Supply

5710 West Good Hope Road
Milwaukee, WI 53223
(414) 358-0333

The W5YI Group

P.O. Box 565101—RE
Dallas, TX 75356
1-800-669-W5YI (9594)

Ham Radio Software

R2 Box 86—RE
Clarence, IA 52216

Amateur Radio Data Systems & Research

C/O Connie Marchik
1007 Cedar Street
Tipton, IA 52772

CIE Gives You The Training You Need to Succeed... At Your Own Pace...& In Your Own Home!

Discover Your Career Potential In The
Fast-Growing Field Of High-Tech Electronics!

If you're anxious to get ahead...and build a *real* career...you owe it to yourself to find out about the Cleveland Institute of Electronics!

CIE can help you discover your career potential in the fast growing field of high-tech electronics. A career that will challenge and excite you every day...reward you with a powerful feeling of personal accomplishment...and deliver a level of financial security you may have only dreamed of before!

As the leading school in home-study electronics, CIE has helped over 150,000 students in the U.S.A. and over 70 foreign countries get started in this exciting field. To find out how CIE could be helping you...read on...then send for a CIE catalog TODAY!

A Growing Need For Trained Professionals!

The career opportunities shown here are only a few of the challenging, high-paying careers you could enjoy as an electronics technician.

You could be the "brains" behind the scenes of an exciting TV broadcast...trouble-shoot life-saving medical equipment...design exotic new aeronautics systems...CIE's job-oriented programs offer you the quickest possible path to the career of your dreams! And CIE also features military and union re-training, to build on what you already know.

Dozens Of Fascinating Careers To Choose From!

Even if you aren't sure which career is best for you, CIE can get you started with core lessons applicable to *all* areas of electronics. As you advance, CIE makes job opportunities available to you through the bimonthly school paper, *The Electron*.



Data Communications



Automotive Electronics



Avionics



Computer-Assisted Manufacturing



Consumer Electronics



Military Electronics

Practical Training... At Your Own Pace.

Through CIE, you can train for your new career while you keep your present job. Each course allows a generous completion time, and there are no limitations on how fast you can study. Should you already have some electronics experience, CIE offers several courses which start at the intermediate level.

"State-Of-The-Art" Facilities & Equipment.

In 1969, CIE pioneered the first electronics laboratory course, and in 1984, the first Microprocessor Laboratory. Today, no other home study school can match CIE's state-of-the-art equipment. And all your laboratory equipment is included in your tuition cost. There is no extra charge—it's yours to use while you study at home and on the job after you complete your course!

Earn Your Degree To Become A Professional In Electronics!

Every CIE course you take earns you credit towards the completion of your Associate in Applied Science Degree, so you can work towards your degree in stages. And CIE is the only school that awards you for fast study, which can save you thousands of dollars in obtaining the same electronics education found in four-year Bachelor's Degree programs!

Personal Training From A Renowned Faculty.

Unlike the impersonal approach of large classroom study, CIE offers you one-on-one instructional help 6 days a week, toll-free. Each CIE lesson is authored by an independent specialist, backed by CIE instructors who work directly with you to answer your questions and provide technical assistance when you need it.

Send For Your Catalog Today!



CIE World Headquarters

Cleveland Institute of Electronics, Inc.
1776 East 17th St., Cleveland, Ohio 44114

YES! Please send me your independent study catalog (For your convenience, CIE will have a representative contact you—there is no obligation.)

Print Name _____

Address _____ Apt # _____

City/State/Zip _____

Age _____ Area Code/Phone No. _____

Check box for G.I. Bill bulletin on educational benefits: Veteran Active Duty

Mail This Coupon Today!

AE07

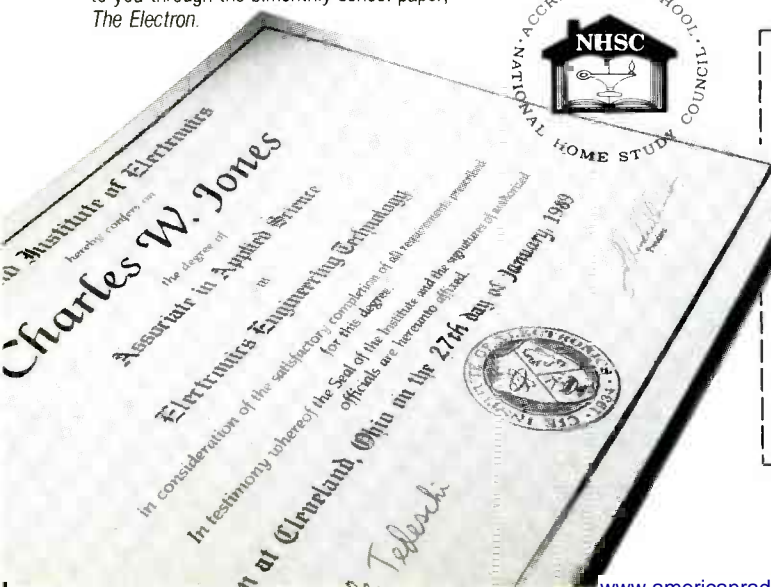

HOW MUCH SHOULD YOU PAY FOR 10 INSTRUMENTS, 39 FUNCTIONS AND 4000 COUNT ACCURACY? Just \$139.95 if you say PROTOMETER™!



- 1 DC VOLTMETER**
- 2 AC VOLTMETER**
- 3 OHMMETER**
- 4 20A AMPMETER**
- 5 DIODE/LED TESTER**
- 6 TRANSISTOR TESTER**
- 7 CAPACITANCE TESTER**
- 8 FREQUENCY COUNTER**
- 9 LOGIC PROBE**
- 10 CONTINUITY TESTER**

PROTOMETER™ 4000 is the Professional Multi-Function Portable Instrument System. Ten test instruments in a 3-3/4 Digit, 4000 count handheld package. Packing the power of our complete instrument line. Combining a digital multimeter, frequency counter, transistor/capacitance tester, and more into a durable no-nonsense

drop-resistant case. Plus standard features like a large LCD display, peak hold, and a unique high-voltage warning indicator. Looks like the competition's DMM and priced like one too!

But PROTOMETER™ 4000 is much more than a DMM. Compare for yourself. Clearly the best value in portable instruments. Why pay just as much for a DMM, when you can get ten test instruments for one low price. How much should you pay? Just \$139.95, if you say PROTO METER™ 4000.

Order Yours Today!! **\$139.95**



Call Toll-Free For Details
1-800-572-1028

**GLOBAL
SPECIALTIES®**

Global Specialties® **A028**
70 Fulton Terrace, New Haven, CT 06512
Telephone: (203)624-3103. ©Interplex Electronics, 1991.

CIRCLE 182 ON FREE INFORMATION CARD

BUILD THIS MAGNETIC FIELD METER

Determine your exposure to line-frequency magnetic-fields with our easy-to-build portable ELF gaussmeter.

REINHARD METZ

IF YOU ARE ONE IN A GROWING number of people who are concerned about the potentially harmful effects of exposure to magnetic fields, you will be interested in this important construction project. Now you can build your own gaussmeter, and determine the magnitude of magnetic flux densities in and around your home. Our hand-held, battery-operated magnetic-field meter is sensitive from 0.1 microtesla (μT) to 20 milliteslas (mT), and has a frequency range from 50 Hz to 20 kHz.

Why all the worry?

Magnetic fields are all around us. They occur from the generation, distribution, and use of 50 and 60-Hz electricity, electronic equipment, and even from Earth's magnetic field, which has always been present throughout Man's evolution. Man has been "tuned" into Earth's steady magnetic field of about $30 \mu\text{T}$ (at sea level) for millions of years. Some sources of excessive magnetic fields that have caused the greatest public concern include power-distribution substations, power lines, CRT terminals, and use of appliances.

Magnetic field intensities can vary greatly, depending on the exposure source and the distance from that source. The rate at which the field intensity falls off with distance can vary from one source to another, depending on how well the current-carrying lines are balanced, or how well the opposing lines of magnetic

flux cancel each other out. Fields from coils, magnets, or transformers drop off rapidly with distance by a factor of $1/r^3$. In power lines, if currents flow in opposite directions, the drop-off is $1/r^2$ because of partial field canceling. When unbalanced current exists, the field intensity falls off less rapidly as $1/r$.

Figure 1-a, -b, and -c show drop-off rates of $1/r$, $1/r^2$, and $1/r^3$, respectively. Figure 2 lists some of the many sources of magnetic field exposure, with their range of intensities and drop-off rates.

Although a great deal of controversy still prevails, many people in the scientific community believe that exposure to magnetic fields of extremely-low frequency (ELF fields of 1–100 Hz) may pose a risk to human health. Some disturbing findings of exposure to ELF fields include a significant increase in serum triglycerides (a possible stress indicator) in hu-

mans, disorientation of chicks (a result suggesting that bird migration could be affected), and a slowed reaction time in monkeys.

A study conducted by epidemiologist Nancy Wertheimer and physicist Ed Leeper, found that exposures to magnetic fields as small as $0.25 \mu\text{T}$ correlated with a rise in cancer rates. In the study, the researchers examined wiring and transformers in the neighborhood of birth homes of children who had died of leukemia between 1950 and 1975, along with those of a control group of children who did not have the disease. The results of their studies were published in *The American Journal of Epidemiology* (March, 1979). Some experts argue that other factors, such as pollution and exposure to chemical carcinogens, make interpretation of those findings very difficult.

Standards for acceptable exposure to ELF fields are emerging, as are results of studies

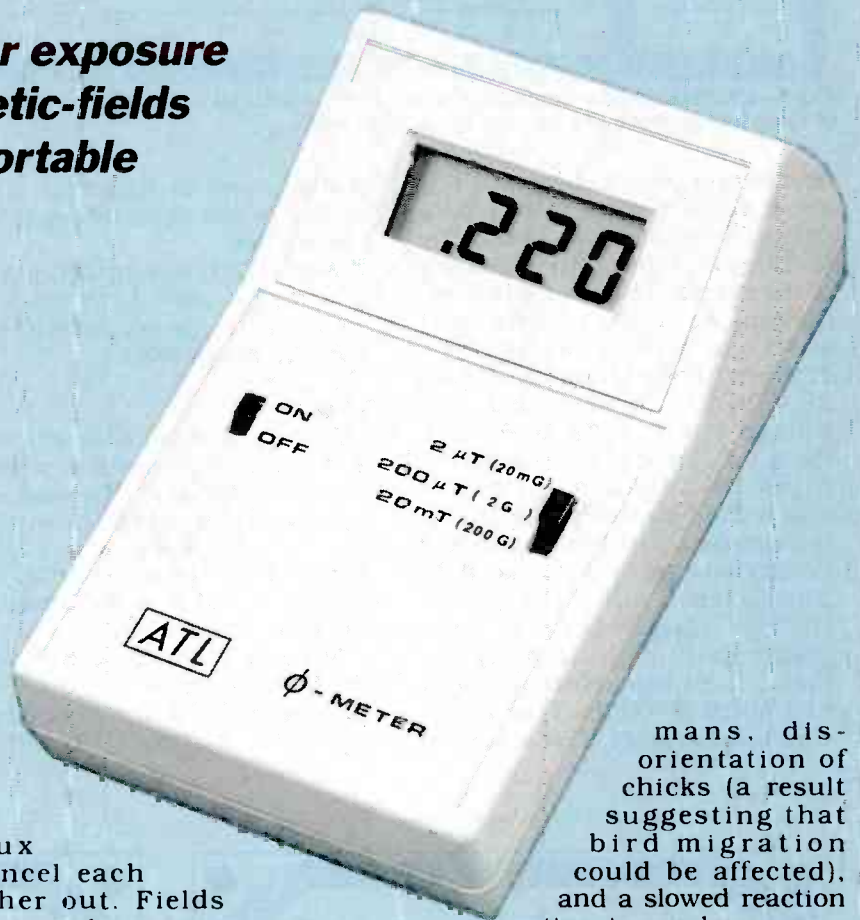

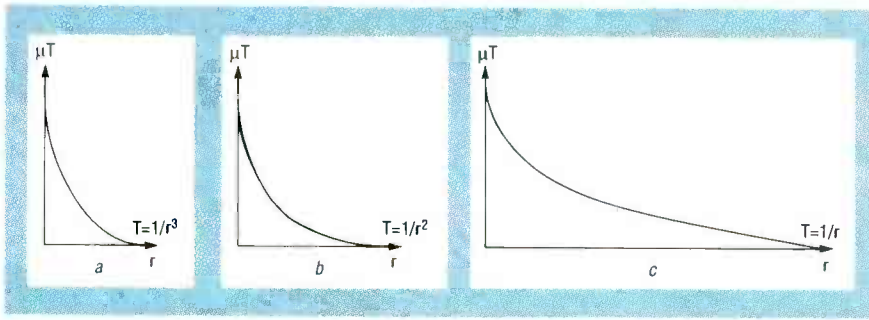

FIG. 1—MAGNETIC FIELD drop-offs. A fast drop-off of $1/r^3$ (a), $1/r^2$ (b), and a slow drop-off of $1/r$ (c) is typical of many sources of magnetic fields.

describing possible hazard levels. If you are more interested a detailed account of scientific findings and the political history of the effects of magnetic-field radiation, we suggest a three-part series of articles by Paul Brodeur, *The New Yorker* (June 12, 19, and 26, 1989). "60-Hz and The Human Body", *IEEE Spectrum*, Parts 1-3, Volume 27, Number 9, pages 22-35 (August, 1990) is also a good source for technical information. The Environmental Protection Agency (EPA) has published a report titled "The Evaluation of the Potential Carcinogenicity of Electromagnetic Fields", publication number EPA/600/6-90/005B. This report contains analyses of 64 scientific

studies, and is currently under review by the Scientific Advisory Committee.

Well, that's enough background for now. Let's examine some of the theory behind how the ELF meter works.

Theory

The quantity of magnetic flux density, \mathbf{B} , is in units of webers/meter², or tesla (T). The magnetic flux, ϕ , is defined by the integral

$$\phi = \int \mathbf{B} \cdot d\mathbf{s} = B \times A$$

where $d\mathbf{s}$ is the differential surface area and A is the area that the coil encloses.

For a coil immersed in a field, the induced open-circuit voltage, E , is equal to the number of turns of a coil, N , times the rate of

change of flux through it.

$$E = N \times d\phi/dt$$

Note that the value of $N \times d\phi/dt$ is actually negative with respect to the induced voltage value, but for our purposes we will just consider the magnitude of the product. The direction of the induced current is such that its own magnetic field opposes the changes in flux responsible for producing it.

If we substitute for ϕ we get

$$E = N \times A(dB/dt)$$

If the magnetic field of a sine wave is $\mathbf{B} = a(\sin \omega t)$, a is the amplitude in teslas and ω is the angular velocity ($2\pi f$), then

$$dB = a\omega(\cos \omega t)dt, \text{ and}$$

$$E = N \times Aa\omega(\cos \omega t)$$

Since $\cos \omega t$ varies from $+1$ to -1 , the peak magnetic field is defined as

$$E = NAa \omega$$

For a frequency of 60 Hz, ω equals

$$2\pi \times 60 = 377$$

For a coil size of $3\frac{1}{2}'' \times 3''$, the area is .0068 m², and therefore

$$E = 2.56 N \times a$$

For the 12-turn pickup coil that we'll use, the sensitivity is 30 μV per μT .

Circuit description

The meter's 12-turn field pickup is integrated into the unit's circuit board. For remote sens-

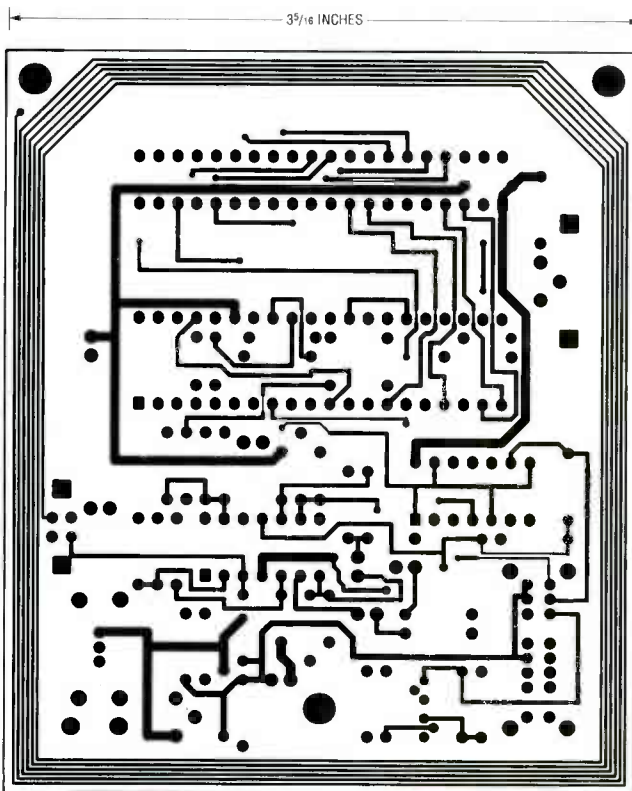

COMPONENT SIDE OF THE PC BOARD.

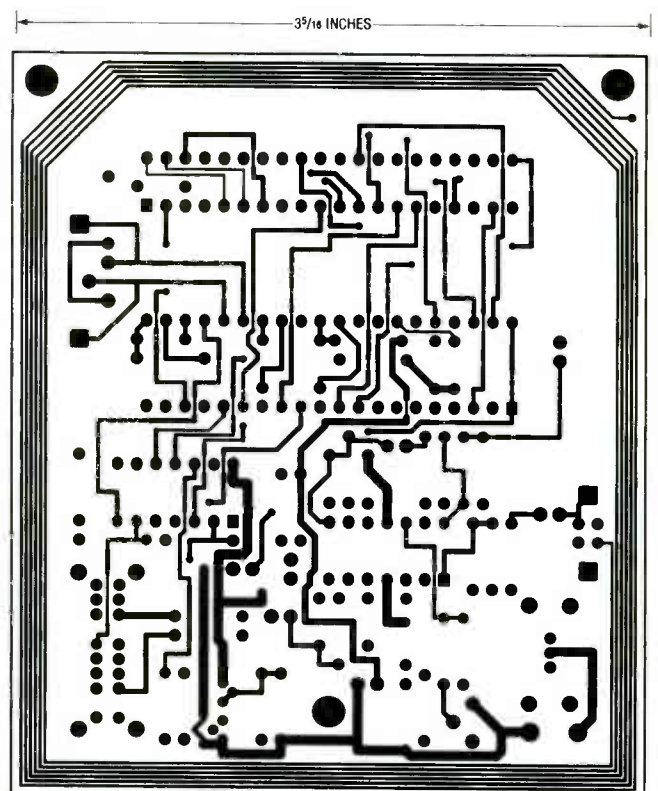

SOLDER SIDE OF THE PC BOARD.

SOURCES OF MAGNETIC FIELD EXPOSURE

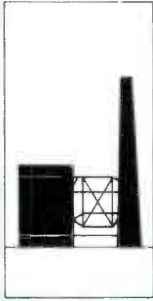

POWER GENERATING STATION
(20KV), 3.0mT

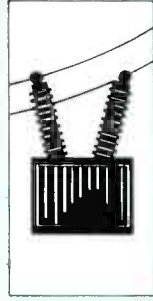

STEP-UP TRANSFORMER
5 - 20μT

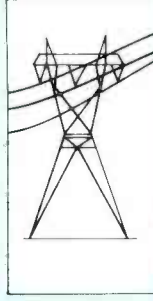

TRANSMISSION LINES
(69-765KV)
5 - 70μT, WITH
MAGNETIC FIELD DROP-OFF
AT $1/r^2$

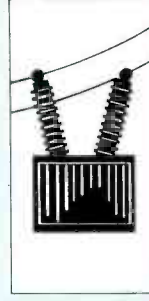

STEP-DOWN TRANSFORMER
5 - 20μT

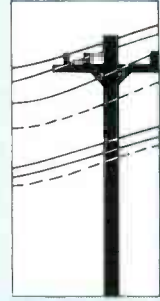

PRIMARY DISTRIBUTION LINES
(4-35KV)
1 - 5μT, WITH MAGNETIC
FIELD DROP OFF AT $1/r^2$



**DISTRIBUTION
STEP-DOWN TRANSFORMER**
0.1 - 1μT, WITH A
FAST MAGNETIC FIELD
DROP-OFF AT $1/r^3$



SECONDARY DISTRIBUTION LINES
(115/230V)
0.1 - 1μT, WITH A SLOW
MAGNETIC FIELD DROP-OFF
OF $1/r$ (DUE TO UNBALANCED
PHASE AND NEUTRAL LINES)

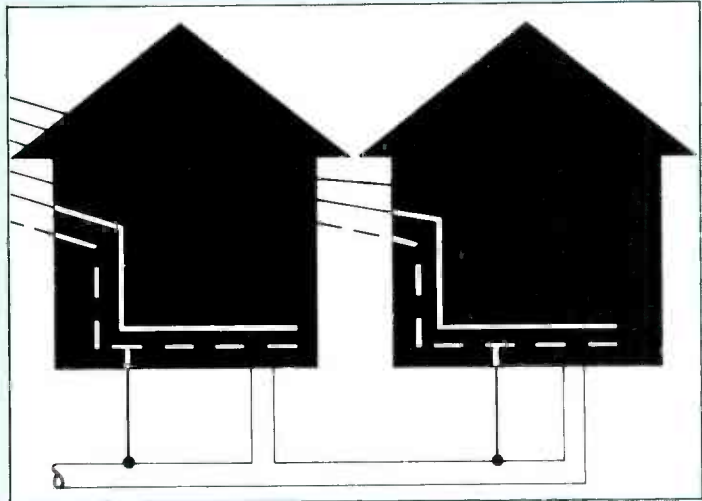

ELECTRIC UTILITY GROUND
HOUSEHOLD WATER PIPES
CARRY RETURN CURRENT AND
CREATE UNBALANCED FIELDS.
GROUND CURRENTS CAN BE
A PRIMARY SOURCE OF CONTINUOUS
EXPOSURE IN SOME HOMES, WITH
A SLOW DROP-OFF
AT $1/r$

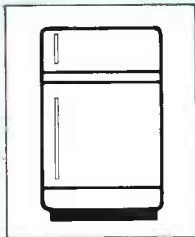

REFRIGERATOR
0.1 - 1μT, SOURCE
OF MAGNETIC FIELD
IS FROM MOTOR IN
BACK OF THE APPLIANCE,
SO EXPOSURE IS LOW, DROP-OFF
IS $1/r^3$

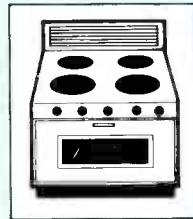

ELECTRIC RANGE
6-200μT, MAJOR SOURCE
OF MAGNETIC FIELD
IS RESISTIVE HEATING
ELEMENTS, DROP-OFF
IS $1/r^3$

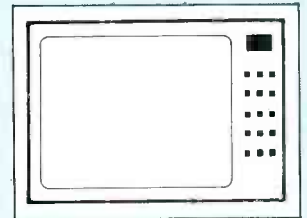

TELEVISION
2-50μT, MOSTLY
RF FIELDS BUT
POWER TRANSFORMER
AND VERTICAL SWEEP
PRODUCE MAGNETIC FIELDS,
DROP-OFF IS $1/r^3$

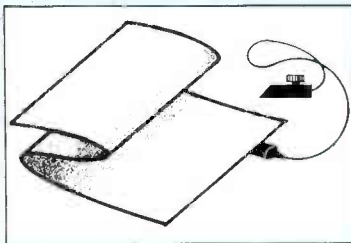

ELECTRIC BLANKET
1-5μT, HEATING ELEMENTS
ARE CLOSE TO BODY, AND FIELD
EXPOSURE CAN LAST OVERNIGHT,
DROP-OFF IS $1/r^2$

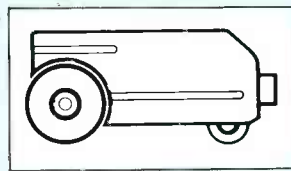

VACUUM
200-1000μT,
DROP-OFF IS $1/r^3$

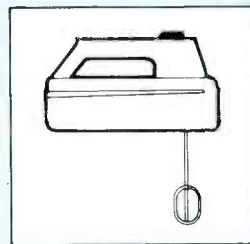

MIXER
50-600μT, DROP-OFF
IS $1/r^3$

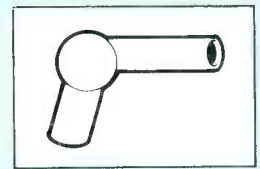

HAIR DRYER
10-2000μT, DROP-OFF
IS $1/r^3$

FIG. 2—HERE ARE SOME PRIMARY SOURCES of magnetic field exposure with the range of field intensity in teslas, and drop-off rates.

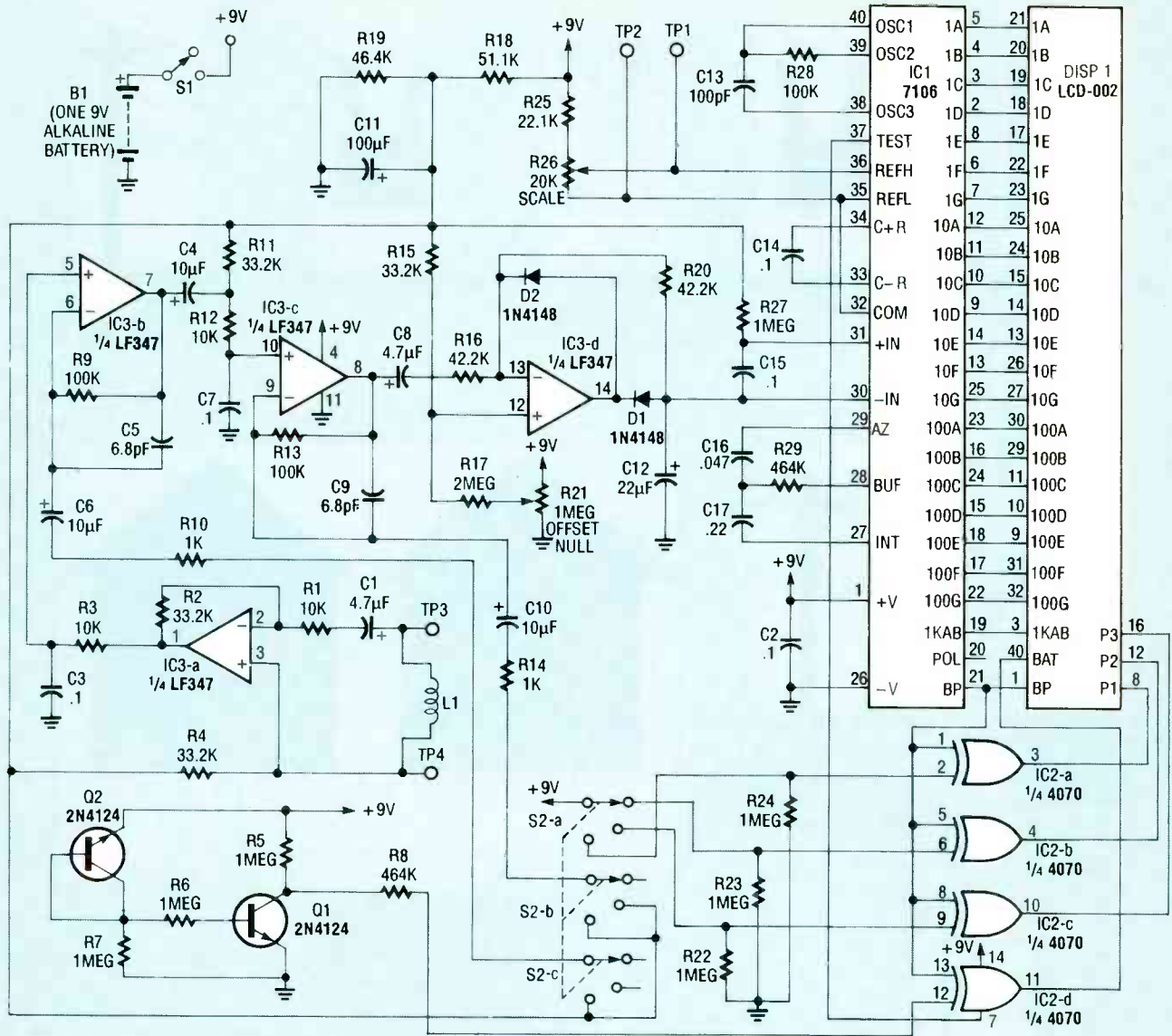

FIG. 3—SCHEMATIC OF THE MAGNETIC FIELD METER. The magnetic field is picked up by L1 and appears as a voltage that is proportional to the field strength at the input of IC3-a, which amplifies the signal to 100 μV per μT . The signal is then further amplified by IC3-b and IC3-c to achieve the three tesla ranges.

PARTS LIST

All resistors are 1/4-watt, 1%, unless otherwise indicated.

R1, R3, R12—10,000 ohms
 R2, R11, R15—33,200 ohms
 R4—10 ohms
 R5-R7, R22-R24, R27—1 megohm
 R8, R29—464,000 ohms
 R9, R13, R28—100,000 ohms
 R10, R14—1000 ohms
 R16, R20—42,200 ohms
 R17—2 megohms
 R18—51,100 ohms
 R19—46,400 ohms
 R21—1-megohm potentiometer, 5%
 R25—22,100 ohms
 R26—20,000-ohm potentiometer, 5%

Capacitors

C1, C8—4.7 μF , 10 volts, electrolytic
 C2, C14—0.1 μF , electrolytic or polyester

C3, C7, C15—0.1 μF , polyester
 C4, C6, C10—10 μF , electrolytic
 C5, C9—6.5 pF, ceramic disc or mica
 C11—100 μF , 10 volts, electrolytic
 C12—22 μF , 10 volts, electrolytic
 C13—330 pF, polyester
 C16—0.047 μF , polyester or ceramic disc
 C17—0.68 μF , polyester

Semiconductors

D1, D2—1N4148 switching diode
 Q1, Q2—2N4124 NPN transistor
 IC1—ICL 7106 A/D converter
 IC2—4070 or 4030 quad 2-input exclusive-OR gate
 IC3—LF347 quad JFET input op-amp

Other components

S1—MSS1200, SPST (Alco)
 S2—MSS4300, SPDT (Alco)

L1—18 turns, 3" diameter remote-sensing coil (optional, see text)

B1—9-volt alkaline battery, with connector Case—Pac-Tec, HPS-9VB

NOTE: The following items are available from A & T Labs, P.O. Box 552, Warrenville, IL 60555: A kit of all parts including PC board and case, without battery, \$85.00; an etched, drilled and plated through PC board with solder mask and silk-screened parts placement, \$15.00; a fully assembled and tested unit, \$109.00. Add 6.75% sales tax for Illinois residents, 5% shipping and handling in U.S., 12% shipping and handling in Canada. Check or money order (UPS COD in contiguous U.S. only) is accepted.

ing, an external field coil probe can be used. Figure 3 shows the complete schematic of the circuit. The magnetic field picked up by the coil appears as a voltage, which is proportional to field strength and frequency at the input of a cascaded amplifier IC3-a, -b, and -c. With a first stage amplifier gain of 3.3 set by R12-R10, the overall sensitivity is 100 μV per μT , or 100 mV per mT. The meter sensitivity is nominally 2 volts full scale, leading to the lowest level sensitivity of 20 mT full scale.

Op-amp IC3-a amplifies the signal to a normalized level of 100 μV per 1 μT . That voltage is further amplified by 1, 100, or 10,000 by IC3-b and -c. The three amplifier stages provide the three magnetic field ranges of 2 mT, 200 μT , and 2 μT (full scale). Components R3-C3 and R12-C7 establish a frequency roll-off characteristic that compensates for the frequency-proportional sensitivity of the pickup coil, and set the 20-kHz cut-off point.

Finally, IC3-d is a precision rectifier and peak detector. Its output drives IC1, a combination analog-to-digital (A/D) converter and LCD driver. Components R25-R29 and C13-C17 are used by IC1 to set display-update times, clock generation, and reference voltages. The decimal points are driven by IC2, as determined by the range-select switch S2. Transistors Q1 and Q2 serve as a low-battery detector, and turn on the battery annunciator in the LCD when the battery voltage drops below 7 volts.

Assembly and checkout

The finished unit shown in Fig. 4 uses a double-sided PC board, which is available from the source mentioned in the parts list. We also show the component side and solder side of the PC board if you choose to make it yourself. You can, however, build the circuit on a perforated construction board if you like, but remember to include the 18-turn remote sensing coil, L1, as indicated in the Parts List. Mount all parts below the LCD display first. It's easier to fix assembly problems if a socket is used with the LCD. Install all parts as shown in Fig. 5 paying attention to component values and capacitor polar-

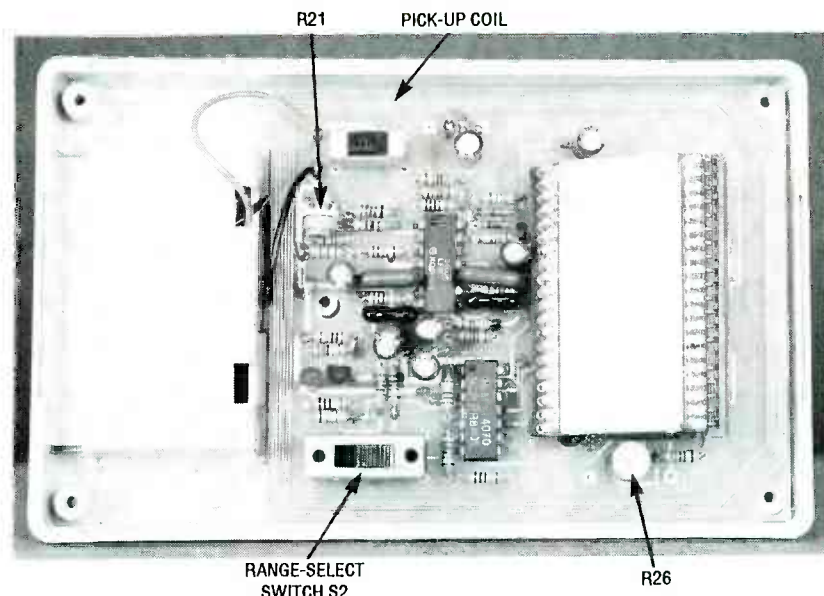

FIG. 4—THIS IS AN INTERNAL VIEW of the magnetic field meter. Assembly is easy, just install all components below the LCD first.

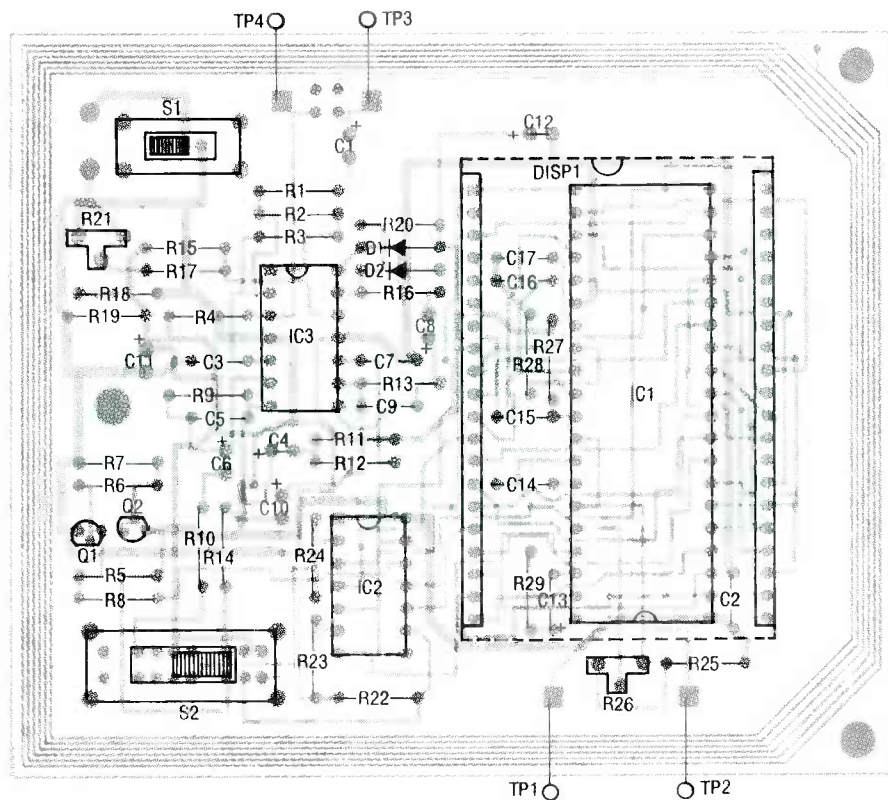

FIG. 5—PARTS PLACEMENT DIAGRAM.

ities. If you are using the internal sensing coil, install jumpers between L1-TP3 and L1-TP4.

If you are using the case specified in the parts list, raise and angle the display as necessary with wire-wrap IC sockets. Make holes in the front panel for S1 and S2. Mount the finished PC board in the case using a spacer for the single screw holding the center bottom of the board, and attach

the battery connector. You are now ready for power-up and checkout.

With power on, adjust R26 for 1.000 volt between TP1 and TP2. Then, select the 20 mT range and short the pickup coil with a very short lead between TP3 and TP4. Adjust offset-null potentiometer R7 for a display of 0.00. Remove the jumper, and the meter is complete.

Electronics Engineers & Designers!

Take any **3** books for only **\$4⁹⁵**
(Values to \$114.85)

SHARPEN YOUR SKILLS—With Quality, Affordable Professional Books

COMPUTER SCIENCE



3279 **\$36.95**
Master the proven repair techniques of an expert electronic technician. 570 pp. *Counts as 2*

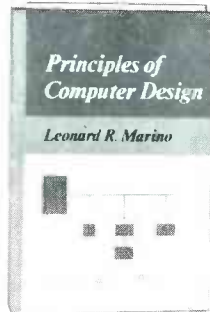

9813 **\$39.95**
Covers logic design, register transfer design, architecture, programming and more. 578 pp.

ENGINEERING MATH

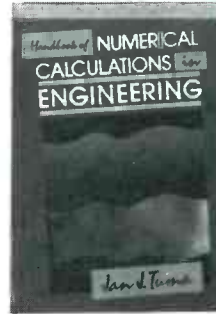

9321 **\$49.50**
This time-saving handbook provides problem-solving calculations for engineering design, production and research. 416 pp. *Counts as 2*

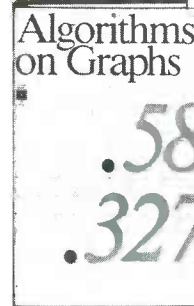

3429 **\$29.95**
Your source for well-developed, ready-to-use computer algorithm codes. 180 pp.

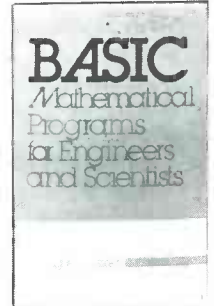

8225P **\$19.95**
Tested programs for most mathematical computing needs. 233 pp.

ELECTRONIC CIRCUITS & COMPONENTS

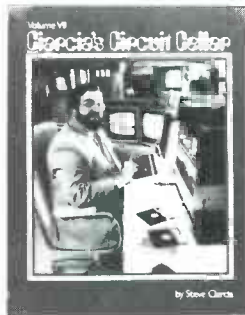

10010P **\$19.95**
More do-it-yourself circuits from the master—Steve Garcia. Step-by-step guidance on projects ranging from a gray-scale video digitizer to parallel interfacing. 256 pp.

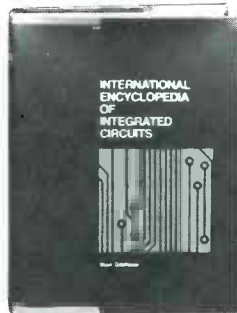

3100 **\$75.00**
This quick-reference provides pin-out diagrams, internal block diagrams and schematics, characteristic curves, descriptions and applications—for foreign and domestic ICs! 1088 pp. *Counts as 3*

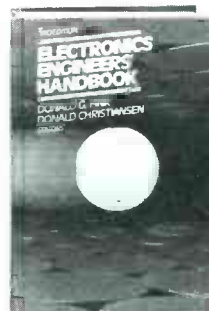

9255 **\$89.50**
"Outstanding, extensive reference to current technology of electronics. Covers everything from principles to applications."
—Computer Book Review
2528 pp., 1800 illus. *Counts as 3*

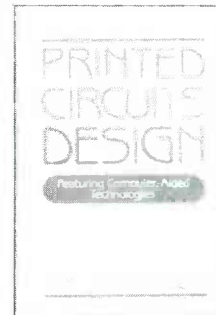

10016 **\$39.95**
Design tighter, more complex circuits, on time and on budget with this book, one of the first to provide a thorough coverage of all aspects of PCB design, including CAD. 320 pp.

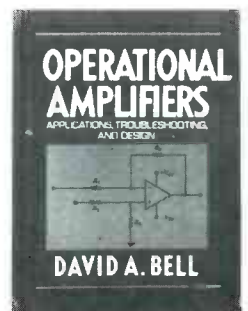

9359 **\$48.00**
Select and use op-amps for any application with total confidence using this lucid guide. It covers the basic operational amplifier circuit and the industry standard 741 op-amp. 364 pp. *Counts as 2*



3258 **\$27.95**
Step-by-step instructions for troubleshooting and repairing the latest in electrical equipment. 310 pp.

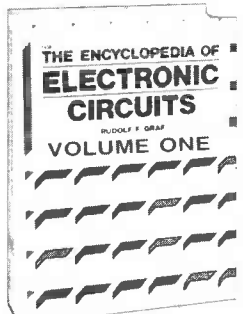

1938 **\$60.00**
Over 1,300 useful and versatile electronic circuit designs. 768 pp. *Counts as 2*

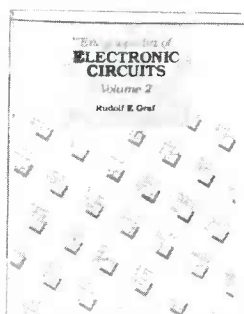

3138 **\$60.00**
More than 700 state-of-the-art electronic circuit designs for on-the-job use. 738 pp. *Counts as 2*



3321P **\$16.95**
A valuable workbench companion covering industrial hardware theory and application. 334 pp.

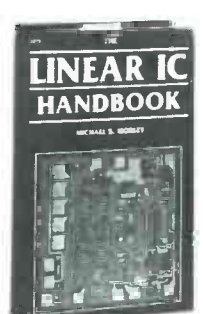

2672 **\$49.50**
Linear integrated circuits—specifications, prices & data. 614 pp.

STATE-OF-THE-ART

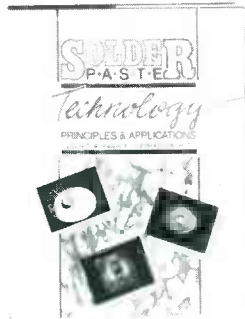

3203 **\$44.50**
An indispensable guide to technology from composition to applications and testing. 400 pp. *Counts as 2*

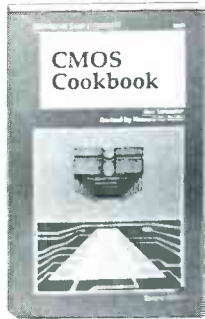

9244P **\$18.95**
This revised and updated edition is both a comprehensive, industry-wide reference, and a valuable collection of project ideas. 512 pp.

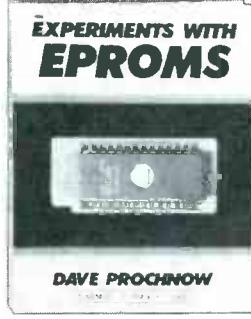

2962P **\$17.95**
Complete schematic diagrams, parts lists, and photos for building a variety of projects. 240 pp.

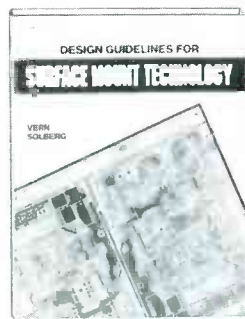

3199 **\$52.00**
Layout and design guidelines for efficient processing, inspection and repair. 180 pp. *Counts as 2*

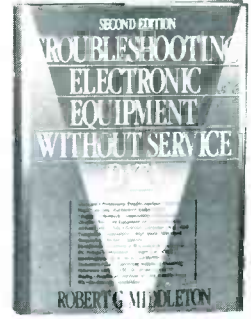

9290 **\$36.00**
Provides many never-before-published troubleshooting techniques and case histories. 315 pp. *Counts as 2*

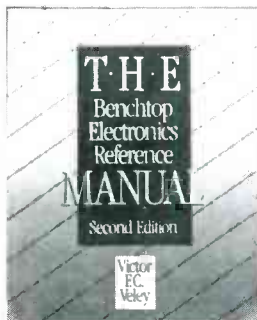

3414 **\$39.95**
Veley has completely updated this edition and added new sections on mathematics and digital electronics. This is the most complete reference available on all areas of electronics. 816 pp., 389 illus. *Counts as 2*

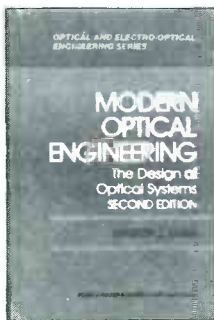

10012 **\$59.50**
Every clear, easy-to-understand technique in the completely updated reference enhances your ability to make sound professional design decisions. 528 pp. *Counts as 2*

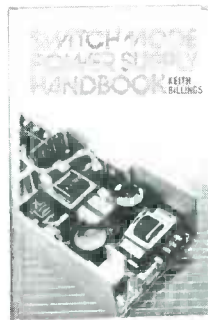

9305 **\$59.50**
The solution-oriented handbook for practicing engineers at all levels. Contains hundreds of informative illustrations and diagrams demonstrating key principles. 600 pp. *Counts as 3*

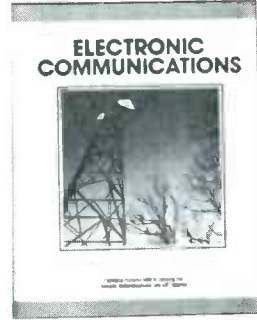

3365 **\$34.95**
Use this broad study to prepare you for your FCC General Radiotelephone Operator License or CET exam, then keep it on your desk as a handy working reference. 704 pp.

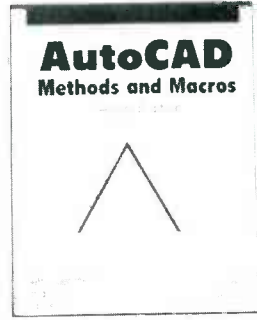

3544 **\$34.95**
This completely revised and updated guide takes you step-by-step through dozens of useful techniques for working through Release 11. 464 pp., 275 illus.

How the Club Works:

YOUR BENEFITS: You get 3 books for \$4.95 plus shipping & handling when you join. You keep on saving with discounts of up to 50% as a member.

YOUR PROFESSIONAL BOOKSTORE BY MAIL: Every 3-4 weeks, you will receive the EE&D Book Club News describing the Main Selection and Alternates, as well as bonus offers and special sales, with scores of titles to choose from.

AUTOMATIC ORDER: If you want the Main selection, do nothing and it will be sent to you automatically. If you prefer another selection, or no selection at all, simply indicate your choice on the reply form provided. You will have at least 10 days to decide. As a member, you agree to purchase at least 3 books within the next 2 years and may resign at any time thereafter.

BONUS BOOKS: Starting immediately you will be eligible for our *Bonus Book Plan* with savings of up to 80% off publishers' prices.

IRONCLAD NO-RISK GUARANTEE: If not satisfied with your books, return them within 10 days without obligation!

EXCEPTIONAL QUALITY: All books are quality publishers' editions especially selected by our Editorial Board.

All books are hardcover unless number is followed by a "P" for paperback. (Publishers' Prices Shown)

©1991 EE&D BC, Blue Ridge Summit, PA 17294-0860

SEND NO MONEY NOW!

INTRODUCTORY 10-DAY FREE EXAMINATION



ELECTRONICS ENGINEERS & DESIGNERS BOOK CLUBSM

Blue Ridge Summit, PA 17294-0860

YES! Please accept my membership in the ELECTRONICS ENGINEERS & DESIGNERS BOOK CLUB and send my 3 volumes listed below billing me \$4.95. If not satisfied, I may return the books within 10 days and have my membership cancelled. I agree to purchase 3 or more books at regular Club Prices during the next 2 years, and may resign any time thereafter. A shipping/handling charge and sales tax will be added to all orders.

--	--	--

Name _____

Address _____

City _____

State _____ Zip _____ Phone _____

Signature _____

Valid for new members only. Foreign applicants will receive special ordering instructions. Canada must remit in U.S. currency. This order subject to acceptance by the Electronics Engineers & Designers Book Club. DRE491

LEARN VCR

CLEANING/MAINTENANCE/REPAIR

EARN UP TO \$1000 A WEEK, WORKING PART TIME FROM YOUR OWN HOME!



Secrets Revealed!

NO Special Tools or Equipment Needed.

EARN UP TO \$60 AN HOUR AND MORE!

THE MONEY MAKING OPPORTUNITY OF THE 1990'S

IF you are able to work with common small hand tools, and are familiar with basic electronics (i.e. able to use voltmeter, understand DC electronics).

IF you possess average mechanical ability, and have a VCR on which to practice and learn. . . . then we can teach YOU VCR maintenance and repair!

FACT: up to 90% of ALL VCR malfunctions are due to simple MECHANICAL or ELECTRO-MECHANICAL breakdowns!

FACT: over 77 million VCRs in use today nationwide! Average VCR needs service or repair every 12 to 18 months!

Viejo's **400 PAGE TRAINING MANUAL** (over 500 photos and illustrations) and **AWARD-WINNING VIDEO TRAINING TAPE** reveals the **SECRETS** of VCR maintenance and repair—"real world" information that is **NOT** available elsewhere!

Also includes all the info you'll need regarding the **BUSINESS-SIDE** of running a successful service operation!

FREE INFORMATION

CALL TOLL-FREE 1-800-537-0589

Or write to: Viejo Publications Inc.

5329 Fountain Ave.

Los Angeles, CA 90029 Dept. RE

CIRCLE 188 ON FREE INFORMATION CARD

Be an FCC LICENSED ELECTRONIC TECHNICIAN!



Earn up to \$30 an hour and more!

Learn at home in spare time. No previous experience needed!

No costly school. No commuting to class. The Original Home-Study course prepares you for the "FCC Commercial Radiotelephone License." This valuable license is your professional "ticket" to thousands of exciting jobs in Communications, Radio-TV, Microwave, Maritime, Radar, Avionics and more. . . . even start your own business! You don't need a college degree to qualify, but you do need an FCC License.

No Need to Quit Your Job or Go To School This proven course is easy, fast and low cost! **GUARANTEED PASS**—You get your FCC License or money refunded. **Send for FREE facts now. MAIL COUPON TODAY!**

COMMAND PRODUCTIONS

FCC LICENSE TRAINING, Dept. 90
P.O. Box 2824, San Francisco, CA 94126
Please rush FREE details immediately!

NAME _____
ADDRESS _____
CITY _____ STATE _____ ZIP _____

42

RADIO-ELECTRONICS

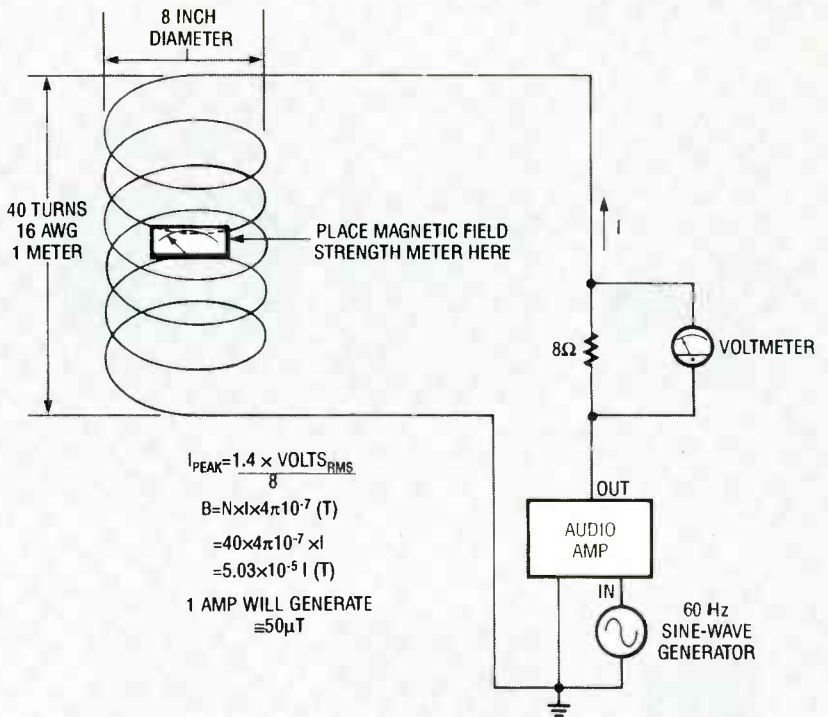

FIG. 6—USE THIS TEST SETUP TO accurately calibrate your meter. A known current is passed through a coil whose field intensity is known. A sine-wave generator provides the 60 Hz frequency, and an audio amplifier is coupled to the coil by an 8-ohm resistor. Measure the voltage across the resistor, and use the calculations shown.

Calibration

Calibration of the meter is basically determined by the pick-up-coil characteristics, amplifier gains, and meter reference-voltage setting. The amplifier gains, as we previously discussed, are chosen to match the coil characteristics as closely as possible.

If you desire to calibrate your meter more exactly, you will need to generate a known magnetic field intensity. One way to do that is to pass a known current through a coil configuration whose field pattern characteristics are known. Figure 6 shows such a calibration setup. A good controllable signal source is a sine-wave generator and an audio amplifier, whose output is coupled to a coil through an 8-ohm resistor. Measuring the voltage across the resistor gives the current. Then, calculate the magnetic field according to Fig. 6. (Note that while all references to field strength here are made in teslas, gauss are also commonly used. The conversion is easy: 1 tesla = 10,000 gauss.)

Place the meter inside the coil and turn it on. Use the highest sensitivity scale that does not overrange the display. An over-

range is indicated by a display of 1 followed by three blanks. In most cases, the $2 \mu\text{T}$ range is satisfactory.

Measurement interpretation

A great deal of controversy exists in the emerging understanding of potential health hazards of low-frequency magnetic fields. The International Radiation Protection Association (IRPA) has set some interim standards based on 1984 World Health Organization guidelines. Those IRPA standards specify a continuous maximum magnetic field exposure for the general public of $100 \mu\text{T}$, and $500 \mu\text{T}$ as the maximum occupational exposure allowed over the entire working day.

Some European countries have already adopted strict magnetic field emission requirements for video display terminals, but the United States is taking a more cautious approach about developing and enforcing such guidelines.

Whatever studies and data you think are accurate, now you have a way to measure your own exposure and take whatever action you believe is prudent.

R-E

LINE POWER FROM 12 VOLTS

**Build a
40-watt
DC-to-AC
inverter, and
power AC**



**appliances
from your
automobile
cigarette
lighter.**

DAVID CUTHBERT

WOULD YOU BELIEVE THAT THIS ARTICLE was written on an electric typewriter while the author was sitting next to a stream on a camping trip? The typewriter was powered from our 40-watt inverter that can be plugged into an automobile's cigarette lighter socket. The unit has enough power for many items that normally don't go on camping trips, such as a TV, a stereo, an electric razor, or a desk lamp. However, it also has some uses that may not be as obvious; it can be used to power items such as an oscilloscope or soldering iron when doing electronics work in the field. On road trips, the inverter can be used to power a camcorder battery charger.

The inverter draws a maximum of 5 amps, which is completely safe for an automobile cigarette lighter socket, and the no-load current is only half an amp. The output voltage is regulated and remains fairly constant from no-load to full-load. Figure 1 shows the output-voltage waveform superimposed over a sine wave. The rectangular output waveform has the same RMS and peak voltage as the sine wave, so the device being powered will

never know the difference. The rectangle-wave operation greatly increases efficiency. The waveform would look similar if displayed on an oscilloscope.

Operation

The inverter, the schematic of which is shown in Fig. 2, is actually a push-pull audio amplifier. The "input," or reference signal, is a 5-volt square wave. The output is 340-volt peak-to-peak AC signal. The feedback signal is rectified in order to match the DC reference signal. On one half of the AC waveform, the upper three FET's are gated on, and on the other half the lower three FET's are on.

Normally, 120-volt AC outlets have one side at ground and one side that's "hot." The hot side alternates from -170 to $+170$ volts. The inverter output is a little different. On one half of the AC cycle, one side is near ground and the other is at $+170$ volts. During the other half of the cycle the situation is reversed.

Op-amp IC1-a and its associated components form a 300-Hz clock oscillator, and counter IC2 divides the clock signal by four to obtain a 75-Hz inverter frequen-

cy. The 75 Hz, rather than 60 Hz, is used to avoid transformer saturation. Some electric clocks will run fast with that frequency, but most electronic gear will work just fine. Decade counter IC2 controls the timing of the reference signal and the gating-on of the error-amp signal to the proper set of FET's.

Figure 3 shows the timing relationships in the inverter. When IC2 pin 3 goes high, the output of buffer IC1-c is high. That reverse biases D1 and allows the error amp signal to reach Q1, Q2, and Q3. At the same time, IC2 pin 4 is low, which causes the output of buffer IC1-d to be low. That grounds the gates of Q4, Q5, and Q6 thereby turning them off. Pins 2 and 7 of IC2 are also low, so Q7 is off. A 5-volt reference from regulator IC3 is now present at the error-amp's (IC1-b) non-inverting input. The reference-signal rise time is slowed by R12 and C2 in order to avoid output overshoot, and the gain and frequency response of the error amp is set by R15, R25, and C3.

Next, pin 2 of IC2 goes high, which turns Q7 on and the reference signal is pulled to ground. Pins 3 and 4 of IC2 are now low

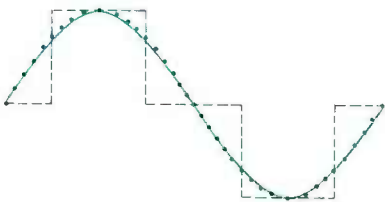

FIG. 1—BECAUSE THE OUTPUT-VOLTAGE waveform, which is shown here superimposed over a sine wave, has the same RMS and peak voltage as the sine wave, the device being powered will never know the difference.

and the FET gates are grounded, turning them off. Pin 4 of IC2 now goes high and the other three FET's are gated on. The reference signal now rises to 5 volts, and the other half of the AC output waveform is generated. The next clock pulse causes IC2 pin 7 to go high; all FET's are now off and the reference is set to zero. The following clock pulse resets IC2 and another cycle begins.

A filter that protects the CMOS circuitry against alternator spikes and reversed input polarity is formed by R7, C8, and D7. Components R9 and C4 filter output spikes, and R18–R21 are pre-load resistors to stabilize the inverter when no load is con-

nected. Although the FET's have no current-equalizing source resistors, they still share current fairly equally. (When a FET "hogs" current it heats up more and its on resistance increases, causing it to draw less current.)

Construction

The inverter circuit was built on a perforated construction board. Transistors Q1, Q2, and

Q3 share a 1.5- by 4-inch heat-sink, and Q4, Q5, and Q6 share another; the heat sinks are made of aluminum sheet. Figure 4 shows an internal view of the inverter. In the prototype, the FET's were not insulated from the heat-sinks because the heatsinks are isolated from ground and all other circuitry. If you use any other heatsinking configuration,

continued on page 68

PARTS LIST

All resistors are 1/4-watt, 5%, unless otherwise noted.

- R1–R7—100 ohms
- R8—1000 ohms
- R9—1000 ohms, 1/2-watt
- R10, R11—4700 ohms
- R12–R16—10,000 ohms
- R17—10,000-ohm potentiometer
- R18–R21—22,000 ohms, 1/2-watt
- R22–R26—100,000 ohms
- R27, R28—470,000 ohms
- R29—1 megohm

Capacitors

- C1—0.001 μ F, ceramic disc
- C2—0.01 μ F, ceramic disc
- C3—0.0047 μ F, ceramic disc
- C4—0.05 μ F, 200 volts, ceramic disc or metal film
- C5–C7—0.1 μ F, ceramic disc
- C8, C9—470 μ F, 35 volts, electrolytic

Semiconductors

- IC1—LM324 quad op-amp
- IC2—4017 CMOS decade counter
- IC3—LM7805 or LM340-5 +5-volt regulator
- D1–D7—1N4003 diode
- Q1–Q6—IRF511 60-volt 3.5-amp MOSFET
- Q7—2N2222 or 2N3904 NPN transistor

Other components

- T1—120/12.6 volt center-tapped 3-amp power transformer
- J1—banana jack, red
- J2—banana jack, black
- J3—AC power receptacle
- F1—5-amp slow-blow fuse
- S1—SPST 6-amp switch
- NE1—neon indicator light with series resistor

Miscellaneous: fuse holder, perforated construction board, enclosure, aluminum for heatsinks, standoffs for mounting circuit board, wire, solder, etc.

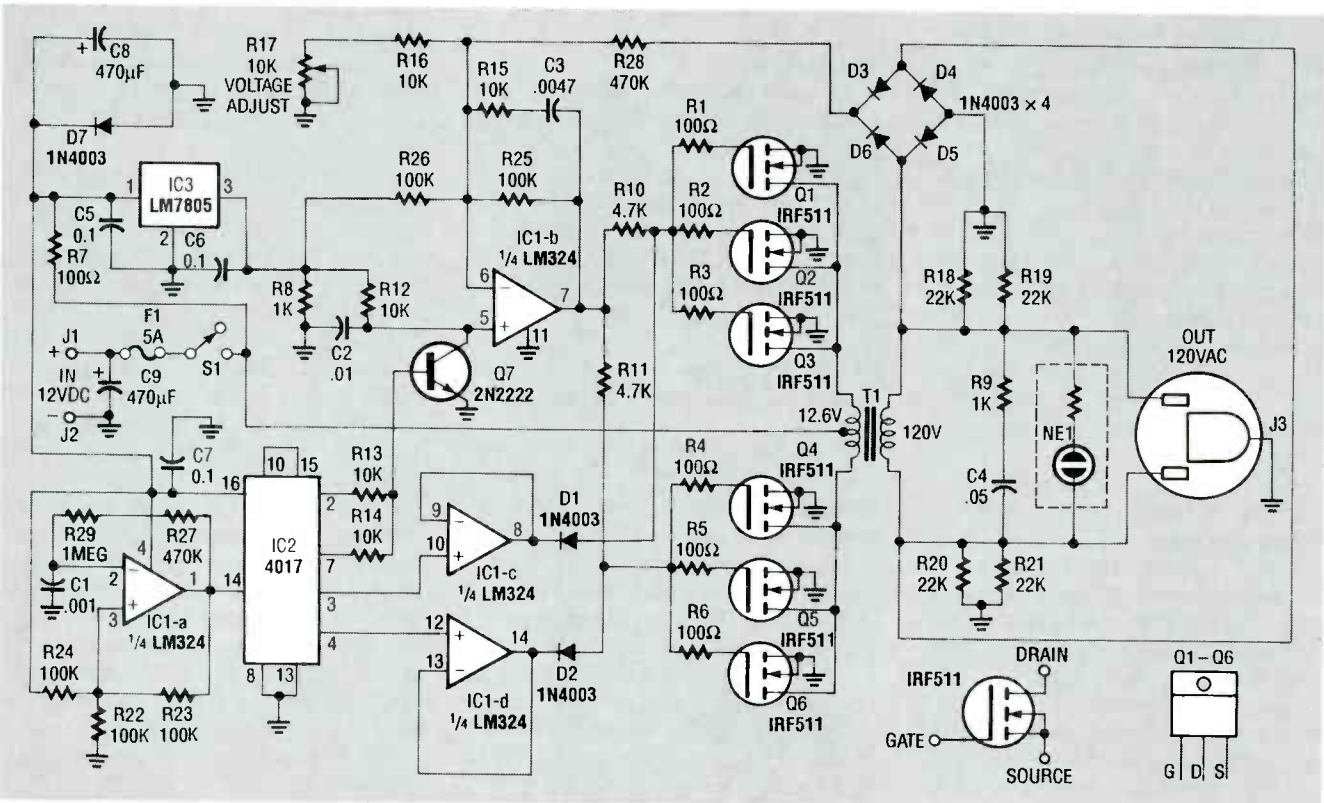

FIG. 2—THE INVERTER is actually a push-pull audio amplifier where, on one half of the AC waveform, the upper three FET's are gated on, and on the other half the lower three FET's are on.

Build this video telephone

Build a two-way videophone and send and receive video pictures over standard phone lines to and from anywhere in the world!

CHARLES COLBY

LAST MONTH WE SAW HOW THE VIDEO phone operates. Now let's build the unit, hook it up, and get it working.

Construction

Building this project is actually very easy, because of the relatively small number of parts used. That's because the video controller IC takes care of many functions by itself, eliminating the need for several other parts.

It's a good idea to use a PC board for this project for two reasons: one, to lessen the likelihood of wiring mistakes, and two, so that you end up with the extremely compact unit you see pictured in this article. We have provided the foil patterns to make the double-sided board if you so desire, or you can also buy a finished board, as well as all other required parts, from the source mentioned in the parts list.

Figure 6 shows the parts-placement diagram for the videophone base unit. There's nothing critical concerning the construction of the unit, just as long as you are careful to observe proper compo-

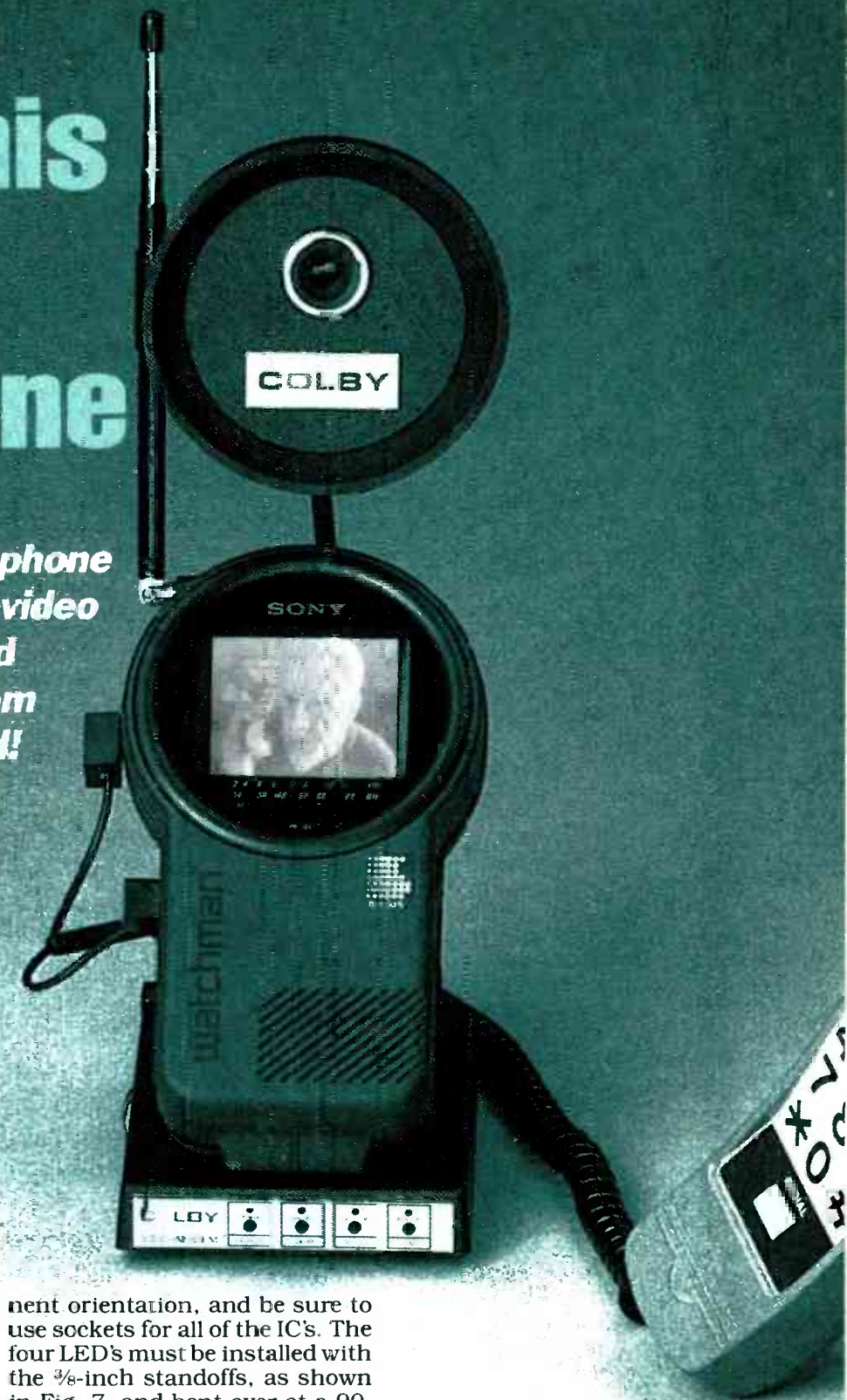

nent orientation, and be sure to use sockets for all of the IC's. The four LED's must be installed with the $\frac{3}{8}$ -inch standoffs, as shown in Fig. 7, and bent over at a 90-degree angle so that they can be seen through the holes in the front panel of the unit. The two voltage regulators, IC1 and IC2, are secured to the metal bottom half of the case we used, for heat sinking. If you don't use the same case, you should consider heat sinking of some kind.

After carefully inspecting the completed board for errors, you

can install it in a project case—the case that the prototype unit is installed in is available from the source mentioned in the parts list, as is the circular case for the small CCD camera module. Figure 8-a is an actual-size label for the front panel of the unit, and Fig. 8-b is for the back. They will fit right onto the available case, but can be used for any setup.

HISTORY OF VIDEOPHONES

The first public showing of two-way videophones was at the AT&T booth at the New York World's Fair in 1939. And, of course, Dick Tracy has always had a two-way videophone on his wrist.

Videophones have had several false starts over the years. While videophones offer a tremendous possibility for exchange of information, there is a certain reluctance on the part of a lot of people to use them. (Is my hair combed alright?) However, one of the main problems with videophones has been the bulky equipment that used to be required.

That was very much the case with the videophones like Robot Research's 1978 picture phone box (see **Radio-Electronics**, August, 1982). With the videophone described in this article with its very small, easily aimed camera, everything (except a phone) fits in about one half the desk space as a standard telephone.

Shown here is the author at age 17 with his 1961 videophone. It used a converted WWII iconoscope camera that measured about 2 feet long, a foot high and 9 inches wide, and weighed 50 pounds. In addition, a 6-foot high rack of equipment was required to send and receive pictures in both slow- and fast-scan rates. Still pictures could be sent over phone lines and amateur radio channels using slow-scan techniques and regular fast-scan full-motion pictures could be sent over 450-MHz ham band TV frequencies.

Slow-scan television (SSTV) was developed during the late fifties to early sixties by amateur radio operators to allow them to send pictures within the narrow bandwidth (3500 kHz) that the FCC permitted for transmissions below 450 MHz. In the old slow-scan format, a frame contained 128 lines. (Regular TV has 525 lines, and the Colby videophone has 260 lines.) The old SSTV format had a horizontal scan rate of a 1/15th of a second (versus 1/15,734 second, or 63 microseconds for regular TV).

Since there was no such thing in those days as a flash A/D converter or "frame grabber," you had to sit still for 8 to 10 seconds while the whole frame was being scanned. If you moved you would blur the picture...similar to the early days of photography when the lens was required to be open for 10 seconds to get the proper exposure. To view the picture on the receiving end, the early SSTV systems used a long persistence P-7 phosphor CRT. That was required because it took 10 seconds to paint the picture on the screen. You could literally see the spot of light created by the scanning beam moving across each line, and by the time the bottom line of the screen was done, the top part of the picture was already fading.

Then came analog scan converters that let you input slow-scan signals and output 1/60th of a second still-video frames. They could be viewed on a regular fast-scan TV without the top fading out, but these analog units were bulky and expensive.

The real breakthrough came in the early 70's when techniques were developed to



CHARLES COLBY looks up at his partner, **Jim Kennedy** (on screen), to check the picture quality on their gigantic 1962 video-phone system.

store and retrieve images using digital techniques. The first solid-state scan converters used many shift registers to store data. The next step was the use of dynamic random access memory (DRAM) chips to store the data that was then converted to video. That's the method used in the videophone in this article.

Slow-scan TV has been used for years by security companies for remote monitoring purposes. Also, many space vehicles still use SSTV to transmit pictures from space. The Viking and the Voyager space probes are good examples. JPL of Pasadena, California has been the main proponent of SSTV use because it's very power efficient—an important factor on long-range space vehicles.

The telephone company had a picture phone center in major cities for years where you could go and sit in a booth and talk and see someone in a similar booth. This was not only inconvenient, but also very expensive.

About two years ago, several Japanese companies introduced home picture-phone units that sold for about \$500.00–\$600.00. These units are about the size of a small shoebox and have a built-in camera and monitor. One problem, though, is that the camera is fixed in position, so the subject must move into the field of view of the camera. The units used an amplitude-modulated protocol which is very susceptible to noise on the phone lines. But the biggest problem, and perhaps the key element that has kept them from becoming widely accepted is the low, 96 × 96 pixel resolution.

Our videophone has overcome many problems. It has a small size, an easily moved and pointed camera, high resolution, 50 shades of gray, a noise-immune pulse-width modulation transmission system, and a high-tech look—it looks like it belongs on your desk!

R-E

PARTS LIST

All resistors are 1/4-watt, 5%, unless otherwise noted.

- R1—510 ohms (× 4) 8-pin SIP
- R2—390 ohms (× 5) 10-pin SIP
- R3—10,000 ohms (× 4) 8-pin SIP
- R4—4700 ohms (× 5) 10-pin SIP
- R5—1000 ohms (× 7) 8-pin SIP, pin 1 common
- R6—1000 ohms (× 5) 10-pin SIP
- R7—1000 ohms (× 3) 6-pin SIP
- R8—110,000 ohms (× 3) 6-pin SIP
- R9—680 ohms
- R10, R19—6800 ohms
- R11—27 ohms
- R12—2000 ohms
- R13—3900 ohms
- R14—8200 ohms
- R15—15,000 ohms
- R16—27,000 ohms
- R17—4700 ohms
- R18—180 ohms
- R20—75 ohms

Capacitors

- C1, C4, C5, C15, C17, C20—470 μF, 16 volts, radial electrolytic
- C2, C3, C9, C18—100 μF, 16 volts, radial electrolytic
- C6, C10, C24—10 μF, 35 volts, radial electrolytic
- C7, C12, C13, C14, C21, C22, C23—0.1 μF, monolithic
- C8—0.1 μF, 200 volts, polyester
- C11—0.05 μF, ceramic
- C16—not used
- C19—4.7 μF, radial electrolytic

Semiconductors

- IC1, IC2—7805 5-volt regulator
- IC3—MP7682 A-to-D converter
- IC4—LM324 quad op-amp
- IC5, IC6—MB81464-12 64K × 4 DRAM
- IC7—PMC-VP video controller
- IC8—GAL16V8 custom A-to-D filter
- IC9—LM393 low-power voltage comparator
- DN1—1N914 (× 8) diode network (contains D1, D3, D9–D13, D16)
- D2, D4, D5—1N4001 diode
- D6–D8, D14, D15—not used
- LED1—LED4—miniature red light-emitting diode
- Q1, Q2, Q5—2N2222 NPN transistor
- Q3, Q4—2N3906 PNP transistor

Other components

- FB1–FB9—ferrite bead over jumper wire
- J1—coaxial power jack
- J2, J6—RCA jack
- J3—miniature phone jack
- J4, J5—modular phone jack
- J7—subminiature phone jack
- J8, J9—3-pin header jumper block
- T1—600/600 ohm audio isolation transformer, 1500 volt rating
- XTAL1—3.57 MHz crystal
- S1—SPST switch
- S2–S5—momentary pushbutton
- RY1—SPST relay, 12-volt coil

Miscellaneous: four 3/8-inch LED stand-offs, PC board, 120 VAC to 12 VDC adapter, three 18-pin IC sockets, one 14-pin IC socket, one 20-pin IC socket, one 48-pin IC socket, one 8-pin IC socket, one 16-pin IC socket, jumper wire, project case, video camera, video monitor, coaxial interconnecting leads (for power and video between base unit and monitor and camera), solder, etc

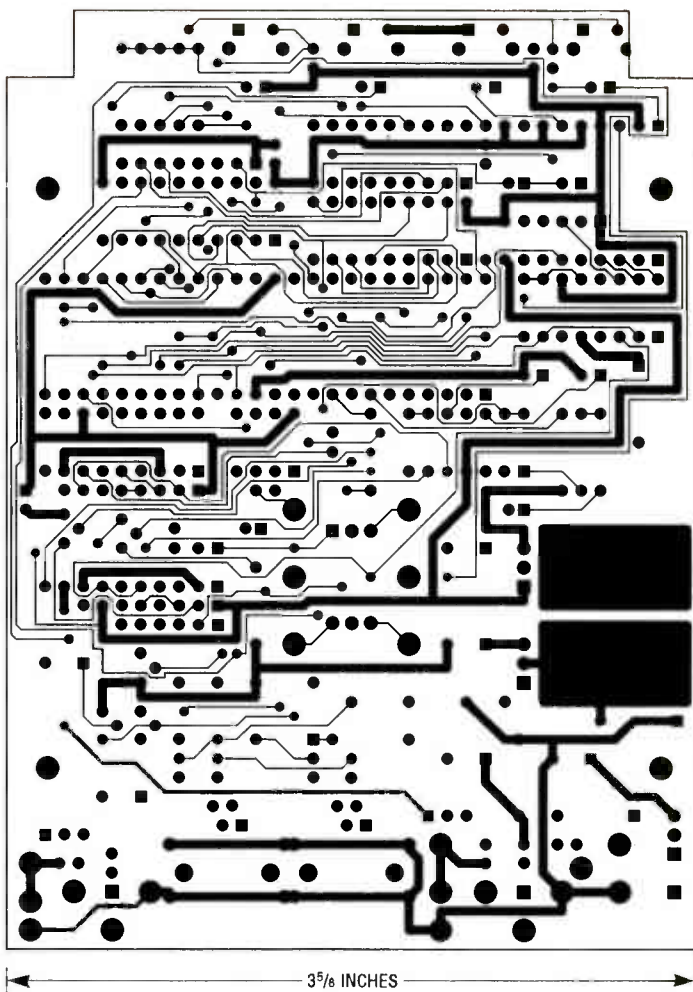
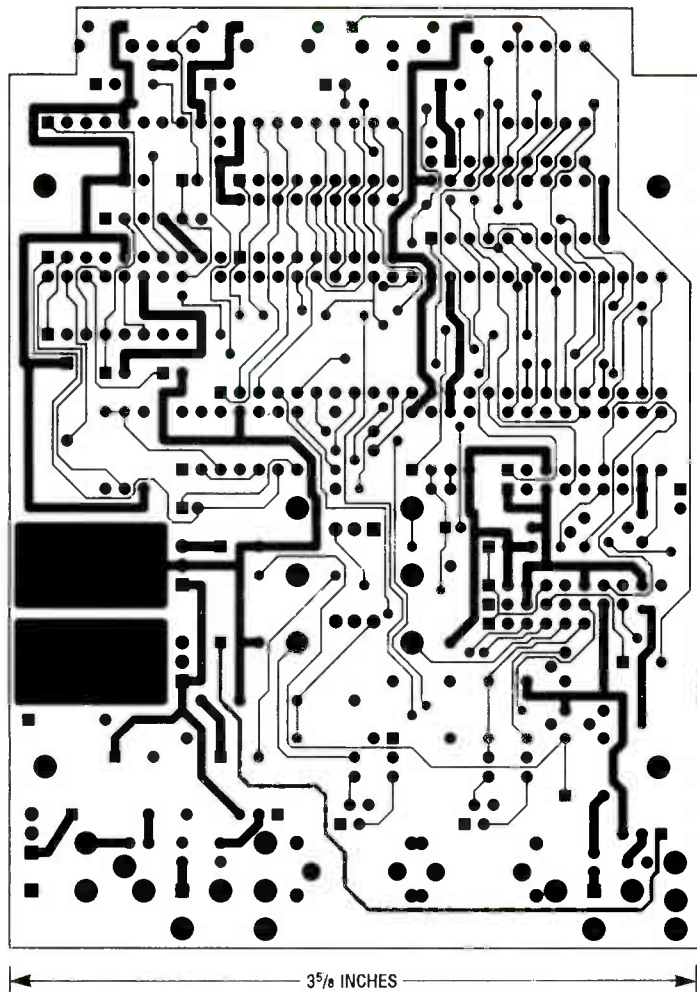

ORDERING INFORMATION

Note: The following items are available from Colby Systems Corporation, 2991 Alexis Drive, Palo Alto, California, 94304 (415) 941-9090, Fax (415) 949-1019. Send check or US postal money order. Checks take 2-3 weeks to clear. California residents add 7.25% sales tax. All prices FOB Palo Alto or Clovis, California. Shipping charges are UPS ground, continental US only, and insurance is included. Add \$5.00 handling fee to each order.

- Bare PC board (PCB-VP)—\$24.99 + \$3.50 S&H
- PMC-VP video controller IC (PMC-U7)—\$49.99 + \$3.50 S&H
- Kit of all other IC's including pre-programmed IC8 (Kit IC-8)—\$39.99 + \$3.50 S&H
- Kit of all discrete components (resistors, capacitors, diodes, transistors, crystal, transformer, jacks, switches, LED's, relay) (kit-VPC)—\$49.99 + \$3.50 S&H
- AC adapter (VP-AC)—\$9.99 + \$4.50 S&H
- Kit of all of the above parts (everything to build one complete videophone base unit, except case) (Kit-unit)—\$169.99 + \$7.50 S&H

- 240 x 320 line CCD camera module (XP-CCD-1)—\$299.99 + \$5.50 S&H
- Sony 2-inch monitor (Sony-2)—\$129.99 + \$4.50 S&H
- Videophone-to-monitor power & video cable (PVC-M)—\$9.95 + \$3.50 S&H
- Videophone-to-camera power & video cable (PVC-C)—\$9.95 + \$3.50 S&H
- All of the above items ordered at one time (Kit-complete)—\$599.99 + \$13.25 S&H
- A VHS video tape showing step-by-step assembly and testing, including sample pictures—\$19.95 + \$4.75 S&H
- An assembled and tested version of the videophone will be available as soon as FCC testing and registration are completed. Write Colby Systems for price list.

The following items are available from Gettys Electronics, 22018 Frontier Road, Clovis, CA 93612 (209) 299-7828.

- Round video camera case (Cam-case-1)—\$29.99 + \$5.50 S&H
- Videophone case with metal bottom and plastic top (VP-case-1)—\$34.99 + \$5.50 S&H.

In the automatic mode, every 38 seconds the videophone connects to the phone line for a period of 12 seconds. Therefore, if you called a monitoring site while the videophone is connected, you would get a busy signal. However, if you wait 12 seconds and redial, the line will not be busy since the 12 seconds will have elapsed and won't start again for another 38 seconds. In actual use, you could hang up on the remote site after you have received one good frame of video. That entire sequence could actually happen in under a minute, since the total cycle time for the videophone is 50 seconds (12 seconds sending and 38 seconds waiting).

That's all there is to it. What was once something that only Dick Tracy could afford to own, is now available to the general public. You will no doubt find many uses for the videophone, and you can be the first on your block to have one!

R-E

Here are two simple projects that will allow you to control things using up to eight voice commands.

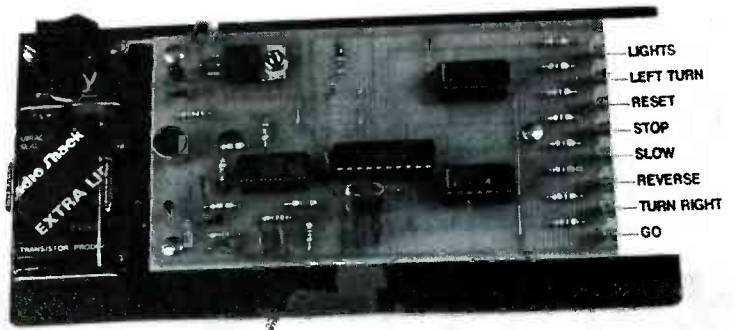

EXPERIMENTS IN VOICE RECOGNITION



DANIEL B. COOPER

SOME OF THE MOST FASCINATING things that electronics experimenters can do are those that seem impossible. Remote control and voice synthesis are two areas of experimentation that were once nearly impossible for hobbyists and amateurs to work with, but integrated circuits have brought both within the reach of even novice tinkerers. Another area that has always been very difficult to work with is voice recognition. And now there is a new IC which brings simple speech-recognition technology within the reach of novice experimenters.

Most voice-recognition projects and experiments have used personal computers as the backbone of the recognition device. A number of voice-recognition expansion cards for both Apple and IBM-compatible computers are available, but they're relatively costly and require the computer in order to be usable. The voice-recognition IC, the VCP200 speaker-independent word recognizer, is a stand-alone device that provides all of the essential elements for speech recognition in a single 20-pin package.

The project

There are a number of applications, both serious and fun, useful and merely entertaining,

for the VCP200. Rather than limit this interesting device to a single-purpose project, we are presenting two separate projects: one is suitable for experimentation—and also makes a nifty science-fair project—and the other is less ideal for experimentation but better for actual use in an application of one sort or another. A variety of adjustments and interfacing techniques will be discussed, and some flexible interface and driver circuits will be presented. None of the parts, with the exception of the VCP200 itself, are exotic or costly, and most are probably in your junk box or parts collection.

The experimenter's version is a self-contained device with a microphone and eight indicator LED's. The addition of a power supply is all that's needed. The project will recognize eight words and short phrases from almost any speaker, and light the corresponding LED in response. Outputs are provided for driving other circuits or devices.

The "working" version of the circuit eliminates the indicator LED's and their driver IC's, and uses a much smaller PC board. However, it retains the eight outputs and all other circuitry, and is therefore more suitable for building into a motorized model or other project.

Voice recognition

The basic elements of voice or speech recognition have been known for a number of years. Human speech consists of phonemes, which are the smallest individual units of sound that make up words and sentences. The "ah" sound in "father," the "t" sound in "top," and the "rr" sound in "radio" are all examples of phonemes. Any word in a particular language can be created by stringing together the proper sequence of phonemes and spaces of silence. Not all languages use the same phoneme sets; English, for example, lacks a glottal stop and the click found in many African languages.

Electronic voice recognition consists of analyzing the arrangement of phonemes in a spoken sequence and matching them against stored patterns or templates to determine the word or phrase. There are many variations in the actual processes used for each of the three steps: storing the patterns, analysis, and matching. However, the basic techniques used for voice recognition can be loosely grouped into four categories.

In speaker-dependent voice recognition, the intended user of the recognition device "trains" it by carefully pronouncing the list of recognized words, several

times each. The system creates detailed templates, or patterns of that speaker pronouncing those words, and stores them. The system will have a very high success rate in recognizing that speaker pronouncing those words, but it will be less able (if at all) to recognize another speaker saying the same words—and, of course, it will only recognize those specific words that it has been trained to recognize.

A discrete-word speech recognizer can only decode speech when it is a series of separately spoken words. It could not understand "Move the cursor to field one," but the sequence "Goto" (pause) "Field" (pause) "One" would be understood. Speaker-dependent discrete-word recognition systems are the most common types in use.

A speaker-dependent connected-word recognition device must be trained to recognize each different speaker's pronunciation. However, more powerful analysis capabilities allow decoding of words strung together in a long phrase or sentence. This type of recognizer could decode "Move the cursor to field one," but is typically costly and complex. The success rates are also typically lower than for speaker-dependent discrete-word recognition systems.

A much more difficult process is to decode the speech of a variety of speakers. No two people pronounce words in quite the same way. When analyzed electronically and graphically, variations, even with very similar-sounding speakers, are quite

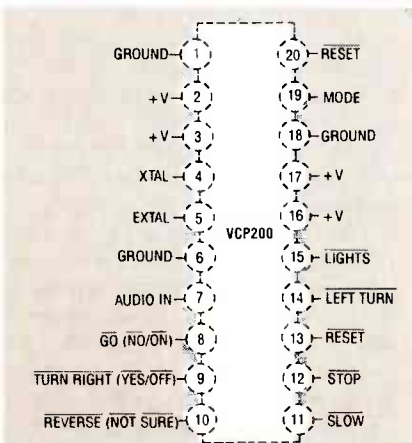

FIG. 1—THE PINOUT OF THE VCP200. The output pins 8, 9, and 10 respond to different words or phrases, depending on the operating mode selected.

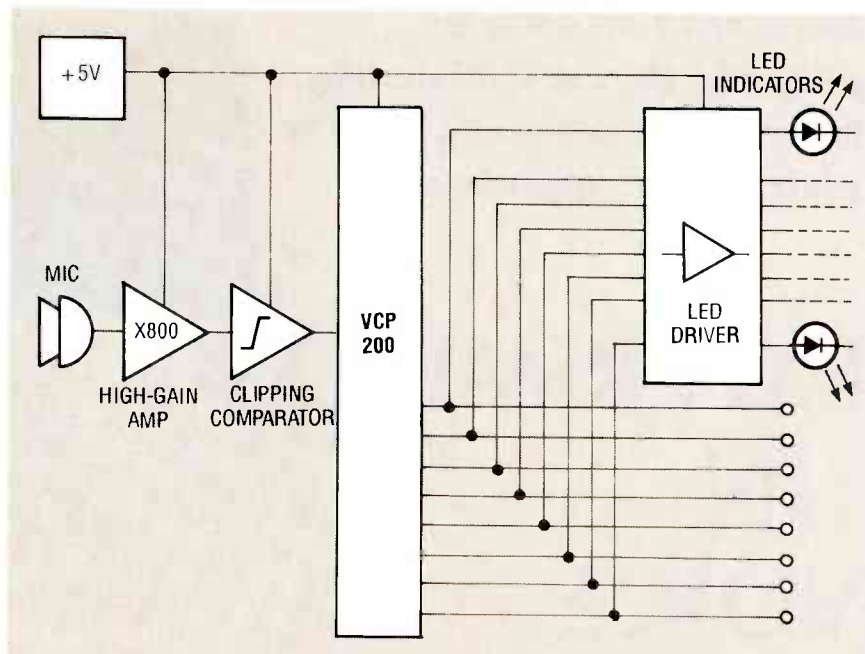

FIG. 2—BLOCK DIAGRAM of the voice-recognition circuit. The VCP200 contains almost all of the required circuitry, and needs only a power supply, microphone, and high-gain amplifier with clipping comparator output for operation. The LED indicators and their drivers are optional.

marked. That natural variation makes it very difficult for a system to recognize, with a high success rate, the same words spoken by different people.

Speaker-independent voice recognition follows the principle that all speakers have certain similarities in their pronunciation. For example, nearly all

speakers pronounce the word "stop" with the following similarities: an initial sibilant ('sss'), a short plosive ('t'), a soft vowel ('ah'), and a final plosive ('p'). By matching selected phonemes and allowing for variation in the matching algorithm, the same words can be identified and decoded from a variety of speakers.

PARTS LIST

All resistors are 1/4-watt, 5%

- R1—2200 ohms
- R2—1000 ohms
- R3—10,000 ohms
- R4, R7—470,000 ohms
- R5—11,000 ohms
- R6, R8—5600 ohms
- R9—4700 ohms
- R10—10 megohms
- R11—100,000 ohms
- R12—19—470 ohms

Capacitors

- C1—0.22 μ F, 16-volts, tantalum
- C2, C3, C12—0.01 μ F disc
- C3—39 pF disc
- C5—4.7 pF disc
- C6—C8—0.1 μ F disc
- C9, C10—27 pF disc
- C11—10 μ F, 16-volt tantalum

Semiconductors

- D1—D8—red light-emitting diode (optional, see text)
- IC1—LM324A quad op-amp
- IC2—LM7805T 5-volt, 1.5-amp voltage regulator

- IC3—VCP200 speaker-independent word recognizer
- IC4, IC5—CD4011B quad NAND gate (optional, see text)

Other components

- JU1—switch or jumper (see text)
- MIC1—electret microphone
- XTAL1—10 MHz crystal

Miscellaneous: PC board (See text), bus wire, SPST power switch, SPDT mode switch, normally open pushbutton reset switch, 9-volt battery or 8–15 volt DC power supply, 9-volt battery clip, three 14-pin IC sockets, one 20-pin IC socket, mounting screws and standoffs, 4-40 \times 3/8-inch screw and nut, hookup wire, solder, aluminum sheet for heatsink.

Note: The VCP200 may be available from Radio Shack (it has been discontinued but many stores still stock them) as part number 276-1308, or from VCPI, 1 Willings Place, Monterey, CA 93940, for \$14.95 postpaid.

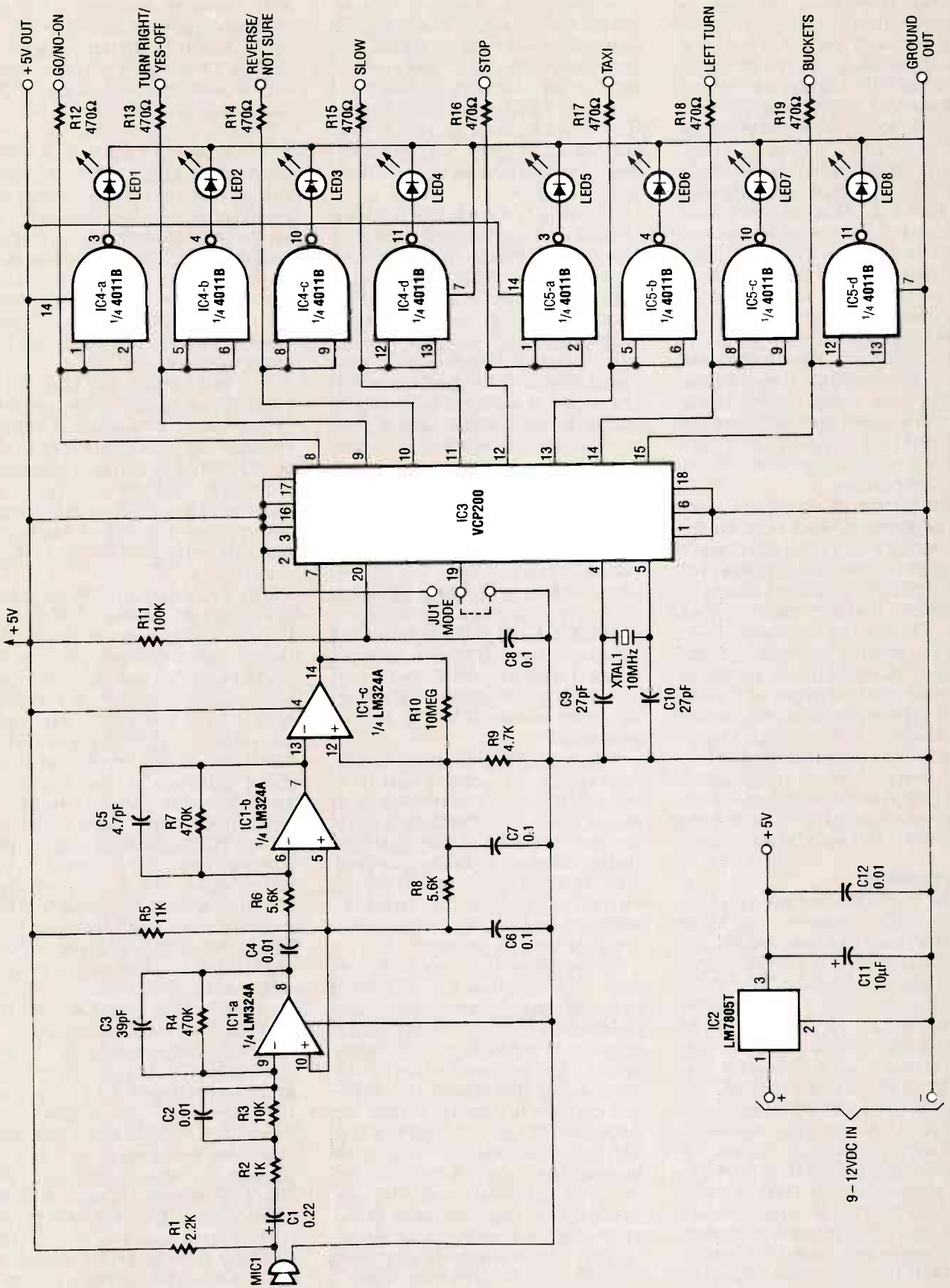

FIG. 3—COMPLETE SCHEMATIC of the voice-recognition circuit. The jumper JU1 may be replaced with an SPDT switch to control the operating mode. Either way will work, but the switch is easier to use.

The drawbacks to speaker-independent systems are that the number of separately recognizable words is limited, the recognition success rate is generally lower than that of speaker-dependent systems, and the system can be easily fooled by similar words. For example, "swap," "stat," "spat," "spot," and "spit" all have phoneme patterns that are similar to "stop." Most speaker-independent word recognition systems will be unable to distinguish between those words.

Most dedicated voice- or word-recognition systems are speaker-independent discrete-word types. Although they have some severe limitations, they excel at simple voice-control tasks involving a few carefully chosen words and phrases. The VCP200 is a speaker-independent discrete-word recognizer.

The dream of designers, control engineers, and science-fiction writers is a system that can recognize normal, connected speech from a wide variety of speakers. Despite much effort, no such system yet exists. The first successful "natural speech" recognizer will almost certainly demand the resources of a dedicated supercomputer to handle the massive analysis and computational steps required. However, keep in mind that speech synthesis, now achieved with single dedicated IC's, also once required a full-sized computer.

The VCP200

The VCP200 speaker-independent word recognizer, from Voice Control Products, Inc. (VCPI), is a mask-programmed Motorola 6804 microprocessor. The 6804 is a 20-pin device that implements most of the standard 6800-series instruction set and capabilities, and contains one kilobyte of onboard ROM. Although an EPROM version is available for user development, production devices such as the VCP200 use a ROM that is mask-programmed at the time of manufacture with the appropriate data and control information. That approach, used for many computationally-based special-purpose devices, is a viable alternative to designing a costly single-purpose chip from scratch.

The VCP200's ROM contains a

phoneme analysis and matching program using a proprietary algorithm. The algorithm analyzes a modified voice input signal and matches it against a selection of stored word-recognition templates to identify twelve different words and short phrases: Yes, No, On, Off, Lights, Left Turn, Reset, Stop, Slow Reverse, Turn Right, and Go.

The chip is switchable between On/Off and Command modes. In the On/Off mode, it recognizes only the two word pairs On/Off and Yes/No. In the Command mode, it recognizes the other eight words and phrases. A separate output for each word is provided, which is latched low when the word is successfully recognized. If the VCP200 cannot find a close match among its word templates, all eight outputs are left high.

The VCP200 is virtually a stand-alone device, requiring only a 10-MHz crystal and four passive components for operation. The only outside circuitry that is required is a special input amplifier, built from a common op-amp, that delivers a sharply clipped and amplified voice signal. That quasi-digital signal can be easily analyzed by the microprocessor.

The VCP200's biggest disadvantage is the limited and non-expandable word list. However, considering that the chip is inexpensive and easy to use, that limitation shouldn't bother anyone who is interested in exploring voice-recognition technology without making a heavy investment of time or money.

Unfortunately for experimenters, VCPI regards the VCP200's program and word-recognition algorithm as proprietary information. Few details are available, and VCPI's literature and documentation discusses the technology only in general terms. An interesting exercise for the advanced experimenter would be attempting to work out the essential elements of the algorithm, using standard reference information on voice recognition, digital analysis of analog signals, and pattern matching.

The pinout of the VCP200 is shown in Fig. 1. The chip is powered from a single-ended 5-volt supply, which connects to

pins 3, 6, and 1, and must provide about 15 milliamps. Its oscillator crystal connects to pins 4 and 5, each of which must also be tied to ground via 27-pF capacitors to complete and stabilize the oscillator tank circuit.

Pins 2, 16, 17, and 18 of the VCP200 are not used in a standard application. They are special-purpose control pins that are usually tied to +V or ground, and are connected that way on our PC board. Generally, these pins may be ignored, as they are normally used to set the VCP200 into various test and special-application modes that are not useful to the experimenter.

The reset input, pin 20, is held high for normal operation and brought low for a reset. A simple resistor-capacitor pair connected to this pin will cause a power-on reset. The VCP200 can be manually reset by strobing the pin low at any time, by holding it low, you can safely disable the chip's operation.

Pin 19 is the operation-mode select input. When this pin is high, the chip is set to the Yes/No mode, and only Yes/Off (pin 9), No/On (pin 8), and Not Sure (pin 10), which indicates a recognition failure, are active. When pin 19 is low, the VCP200 is placed in the Command mode, and all eight outputs are active, with each corresponding to a different recognized word or phrase.

The VCP200's audio input, pin 7, requires an input signal that is either quiescent, or swings past the digital logic thresholds. That requirement translates into a highly amplified, sharply clipped signal that is "shut off" when it is not of sufficient amplitude. Such a signal is easy to achieve with a standard op-amp, as we'll see.

Finally, pins 8 through 15 are the VCP200's outputs. During or after a reset (pin 20 brought or held low), all eight outputs are held high. When the chip successfully recognizes a word or phrase in Command mode, the corresponding output will be latched low until the next recognition attempt occurs. If the VCP200 fails to find a match to an input signal, all eight outputs will remain high. In the Yes/No mode, during or after a reset, pins 8, 9, and 10 (as well as the five unused outputs, pins 11-15)

will be high. Some recognition failures in the Yes/No mode can also cause all three active outputs to go high.

The circuit

As said earlier, there are two versions of the circuit. A block diagram of the experimenter's version is shown in Fig. 2. The circuit contains a power supply, an input amplifier and comparator, the VCP200, and output drivers. The power supply is quite conventional, using IC2, an LM7805T 5-volt regulator.

The input amplifier is not a conventional design; the output signal, if it were connected to a speaker, would be quite distorted and unlistenable. The purpose of the two-stage amplifier, with its overall gain of about 800, is to increase the microphone signal to a useful level. The output is then passed to a comparator that keeps the final output signal ei-

ther quiescent (flat-line) or switching between the supply limits—a quasi-digital signal. The output of the amplifier is passed to the VCP200's audio input, where the signal can then be analyzed.

The VCP200's eight outputs are made available, via current-limiting resistors, so that external interface circuits may be added to control motors, solenoids, and other active elements. Eight LED's are added to give a quick and easy indication of the circuit's response. The LED's are driven by CMOS buffers, which isolate the LED's from the outputs, preventing either the indicators or any outlying circuits from interfering with each other.

Figure 3 shows the complete schematic for the experimenter's version of the voice-recognition project. Note that the schematic of the working version would be exactly the same, except for the

omission of LED's 1-8 and IC4 and IC5.

Power for the voltage regulator, IC2, can be from 7.5 to 15 volts. Since the circuit draws only about 22 milliamps peak, a 9-volt battery is a good choice. Capacitors C10 and C11 filter and stabilize the regulator's output.

The signal from the electret microphone, MIC1, is coupled to the LM324A op-amp, IC1, through C1. The amplifier uses IC1-a and IC1-b to form a two-stage device that amplifies the microphone signals with a gain of 500-800. That transforms the weak input signal (under 5 mV) to a signal that swings from one output limit to the other, often with considerable clipping.

The amplifier has a restricted bandwidth, with a more or less flat response from about 500 Hz to 9 kHz. Signals under 300 Hz and over 15 kHz are sharply attenuated. That covers the

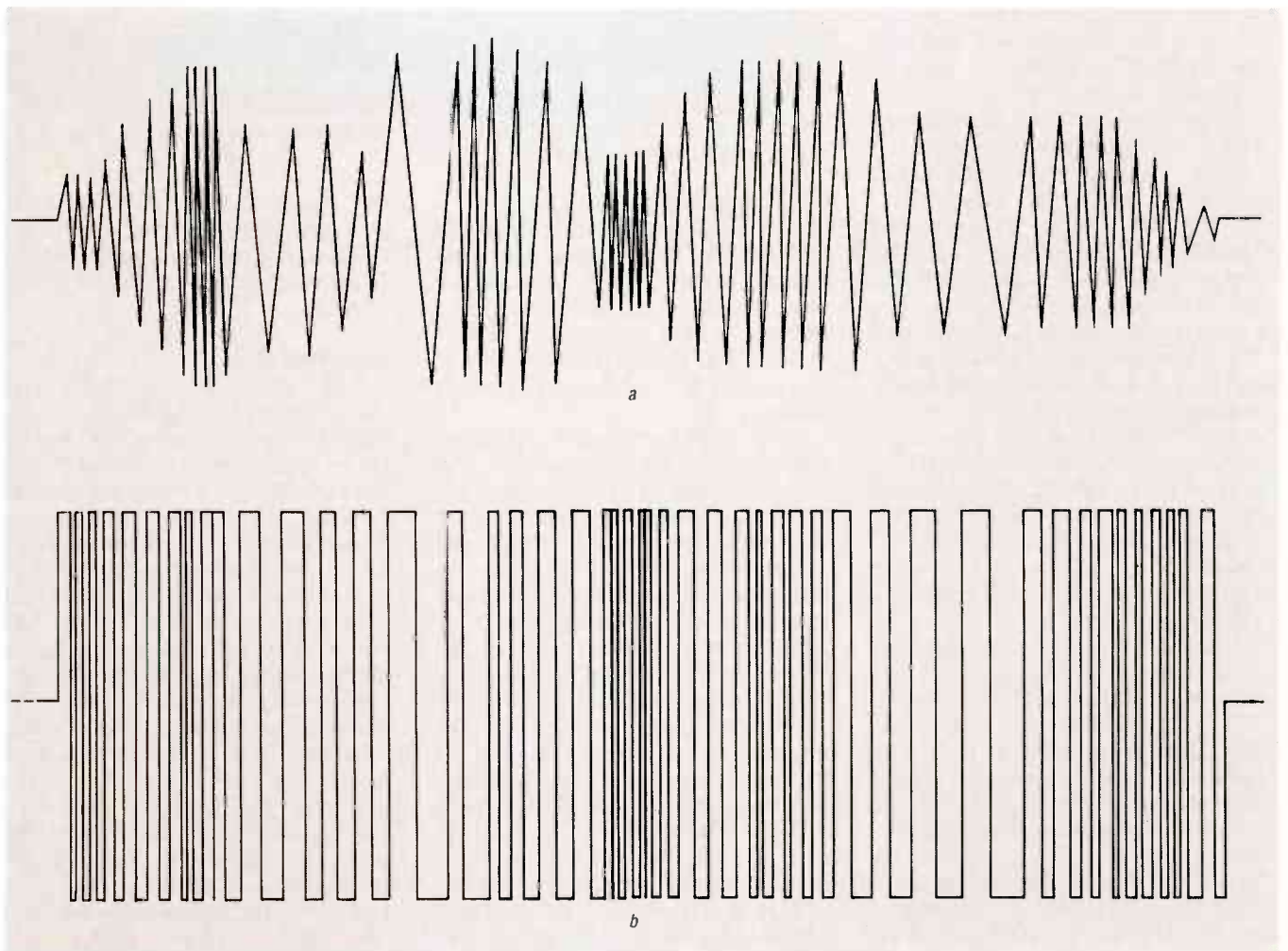

FIG. 4—AMPLIFIER (a) AND COMPARATOR (b) output waveforms. The comparator converts the amplifier signal into a clipped, quasi-digital 4-volt p-p signal only when the amplitude of the amplifier's signal exceeds the comparator threshold.

VCP200's input range of 300 to 5500 Hz. with some additional headroom for the easily-lost higher frequencies. The amplifier's characteristics are important, because the quality of the input signal largely determines how well the voice recognizer will work.

To keep the VCP200's input quiet, unless a signal of sufficient strength is present, and to ensure a sharply clipped signal, the output of the amplifier is passed to a comparator, IC1-c. (The fourth op-amp on the LM324A, IC1-d is not used, and its pins are left unconnected.) The comparator's output remains steady unless the input signal swings past its threshold. Input signals of less than 2.5 volts peak-to-peak will be ignored. However, all signals stronger than that will cause the comparator's output to swing from limit to limit, or about 4 volts peak-to-peak, which is within one-half volt of each supply rail. A comparison of the amplifier and comparator output signals is shown in Fig. 4.

Since the LM324A is operated from a single-ended supply, a "false ground" or offset voltage must be provided. The offset, along with the comparator threshold voltage, is provided by the voltage divider string R5-R8-R9. The amplifier offset is provided by the upper junction, and the comparator threshold by the lower: C6 and C7 stabilize those voltages. That design forces the center voltage of the op-amp's output signal to be separated by a volt or so from the comparator's threshold, and is the key to correct operation. Adjusting the divider string is one of the ways that the circuit's performance can be modified.

The output of the comparator is then routed to pin 7 of the VCP200. The 10-MHz crystal, XTAL1, provides the chip's master clock frequencies, with the oscillator tank circuit completed and stabilized by C9 and C10. To provide a power-on reset, the RC pair R11 and C8 hold the VCP200's reset input low for a few milliseconds after power comes on. As C8 charges through R11, the reset pin is brought high, resetting the VCP200.

The VCP200's mode input, pin

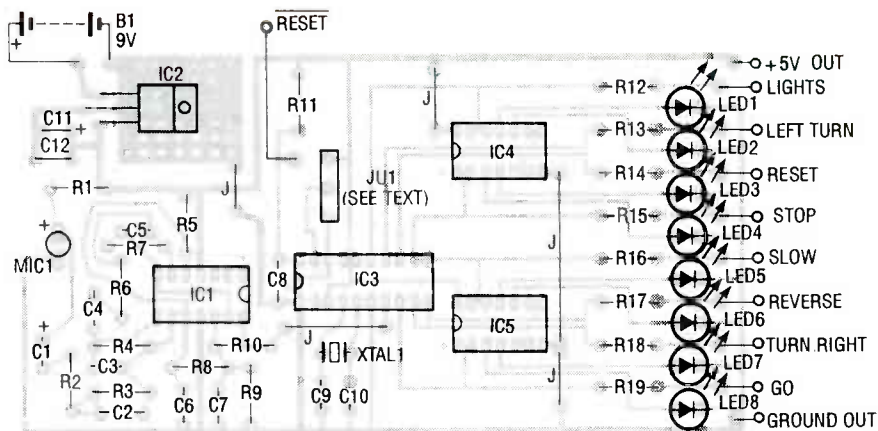

FIG. 5—THE COMPONENT LAYOUT for the experimenter's version. The "working" version parts layout is the same except for the smaller PC board that omits the LED's and their drivers IC4 and IC5.

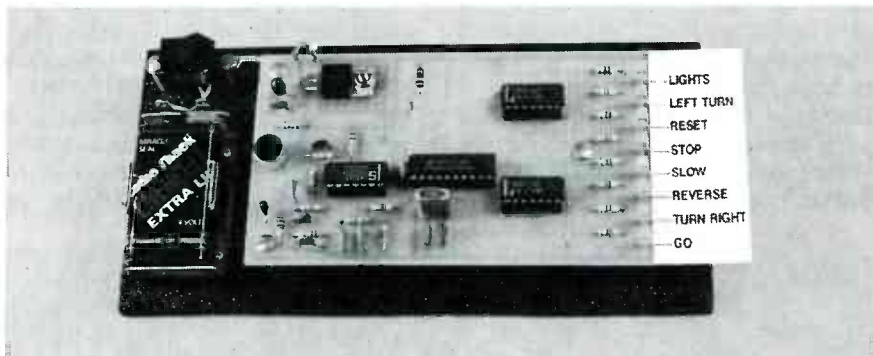

FIG. 6—THE VOICE-RECOGNITION CIRCUIT offers eight voice-activated outputs for experimenting with voice control.

19, is controlled by setting JU1. On the PC board, JU1 is actually three pads which may be connected to an SPDT switch, or simply jumpered. However, jumpering is not recommended; a switch will make it easier to experiment with both operation modes.

The eight outputs, pins 8 through 15, are left open for the experimenter to use as necessary. Since the outputs are active-low, they can sink about 10 mA and source somewhat less. That is sufficient enough to drive logic devices and transistor drivers. If high-current devices such as relays or motors are to be driven, a buffer/driver must be used. To prevent damage to the VCP200 from an accidental overload of an output, 470-ohm current-limiting resistors (R12-R19) are provided. They limit the output current to about 9.5 mA, even under worst-case conditions.

The eight LED indicators, LED1-LED8, are driven from CMOS drivers IC4 and IC5, which are CD4011B quad NAND gates. However, several other

common chips could be substituted here, among them the CD4001B quad NOR gate and the CD4093B quad NAND Schmitt trigger.

Construction

Foil patterns are provided for both versions. Although a PC board is recommended, perforated construction board and point-to-point wiring could also be used. If you use point-to-point construction, be sure and keep all wiring, especially in the area of the input amplifier, short. The very high gain of the amp will cause it to pick up and amplify electrical noise if excessively long connecting wires are used. You should use sockets for all the IC's to make them easier to replace if necessary.

If you are going to build the experimenter's version of the project, follow the parts-placement diagram shown in Fig. 5. If you are going to build the smaller "working" version, simply use the smaller foil pattern; parts placement is the same as the larger version, except that the

LED's and their drivers, IC4 and IC5, are left out. On both, keep the wire jumpers and resistors close to the board. Insert the disc capacitors so that their bodies are seated against the board, but don't chip the dielectric material. Be careful to observe the polarity on the two electrolytic capacitors, C1 and C11.

The voltage regulator, IC2, requires special mounting. The middle lead should be bent about 0.1 inch farther from the body than the two side leads, and all three bends should be made so that the regulator's mounting hole lines up with the hole in the board (see the photo in Fig. 6 for details.) If you are going to be using the project by itself, with no outlying devices powered from the board, no heatsink is needed for the regulator. If you are going to be powering other devices from the regulator that will increase the load to more than 100 milliamps, a heatsink should be added to the regulator. A flat aluminum stock heatsink can be bent into a shallow "U" shape and installed under the regulator. Because there is no space for a large heatsink, the current drawn from the regulator should be limited to no more than 250 mA even when using as large a heatsink as possible.

For most experimenters, mounting MIC1 directly to the board will be adequate. In some cases, though, it may be better to mount the microphone remotely. In that case, light-gauge shielded cable should be used to connect the microphone to the board. Electret microphones are polarized, so be sure the positive terminal is connected to the pad that leads to C1 and R1.

If you like, the eight LED indicators can be mounted remotely with a length of ribbon cable. If you mount them on the board, be sure to position them all at an even height. How you finish the remaining steps depends on how you want to use the board. For display and experimentation, you'll want the input and outputs of the circuit easily accessible with test points. Otherwise you can hardwire driver circuits and the like directly to the board.

In the prototype, the PC board and power switch are mounted to

Command	Pronunciation	Comments
Yes	yeSSS	Both of these words should be longer than "No" or "On," with emphasis on the final sibilant.
Off	awFFF	
No	no	These words should be kept very short. You'll find that almost any short, sharp sound will be interpreted as one of these words.
On	on	
Go	go	
Lights	LytSSS	Emphasize L and S.
Left Turn	LeFFFT Turn	Emphasize F and the two T's, and separate words clearly.
Reset	rESSSeTT	A difficult word for the VCP200 to recognize. Emphasize the first E, S, and final T.
Stop	SSSTawPP	Emphasize T and P. Keep short, but longer than "Go".
Slow	SSSlöh	Emphasize S and vowel.
Reverse	rEverSSS	Another difficult word for the VCP200. Emphasize first E and final sibilant, but do not separate syllables.
Turn Right	Turn-ryT	Emphasize T's and slur words together slightly.

a thick plastic base using spacers and screws, and the battery clip is secured by smaller screws. Although the prototype has no reset switch and is strapped into the Command mode, you can easily add the controls. Just use a slightly larger mounting base and mount the switches in the same manner. If you are using the working version, and will be using it as a part of a complete project or more complex setup, use your judgment as to mounting the board.

Testing

When you have the board (either style) finished, leave the IC's out of their sockets and connect the power terminals to 9–15 volts DC. Then check for +5 volts DC at pin 3 of the regulator, pin 4 of IC1, pin 2 or 3 of IC3, and (with the experimenter's unit only) pin 14 of IC4 and IC5.

Disconnect power, insert IC1, and then connect power again. Check for an AC voltage at pin 7 of IC1. It should vary with the level of sound up to about 2 volts peak. Check the voltage at pin 14 of IC1. When the sound level is high enough, a 2-volt signal should be present. If the comparator is functioning correctly, pin 14 should switch between no signal and a 2-volt AC signal,

with nothing in between. If you're using an oscilloscope, look for a 0–4 volt signal at pin 7, and a 0 or 4 volt clipped signal at pin 14.

Once the board has passed these tests, remove the power and insert the rest of the IC's. When you reconnect power, all LED's should remain off, or if you're using a board without the indicators, all of the outputs should be high. Say "Go." The appropriate LED should light (or the output will go low). Try the other phrases to make other LED's light. Don't worry if the circuit doesn't seem to respond well—it takes a little practice to speak the words and phrases clearly enough for the VCP200 to understand. Table 1 explains how to pronounce the words so that the VCP200 will understand them.

Modifications

The gain of the amplifier may be adjusted by changing the value of R4, R7, or both. Adjusting R7 is preferred. The higher the resistor values, the higher the gain of the amplifier. Lowering the gain will lessen the circuit's sensitivity to background noise, but will require the operator to speak rather loudly and directly into the microphone. Raising the

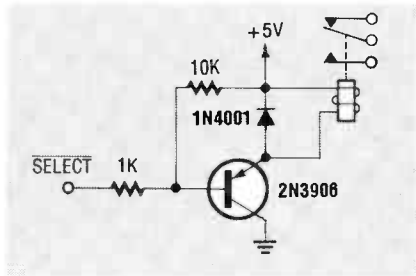

FIG. 7—BASIC POWER DRIVER CIRCUIT for interfacing the project to motors, lamps, or other high-current devices. The relay must have a 5-volt coil, but can have any arrangement of contacts suitable for the application.

gain will allow softer speaking from a greater distance, but at the expense of greater sensitivity to noise.

The frequency response of the amplifier is about 300 to 9000 Hz. Since the VCP200 responds to frequencies from 300 to 5500 Hz, reducing the upper cutoff point of the amplifier to 6000 or 7000 Hz would probably make it less sensitive to noise. If you are familiar with op-amp circuit design, a good way to improve the project would be with a high-precision bandpass amplifier. It should have a nearly flat response from 500 to 6000 Hz, with a sharp rolloff (third-order or better) at each end. The flatter the bandpass response and the sharper the cutoff points, the better the overall performance is likely to be. Higher frequencies are more sharply attenuated by distance and may need extra boost (actually less cut) in order for the VCP200 to successfully decode them.

The comparator threshold is set by the lower output of the resistor divider string R5-R8-R9. Since the artificial ground level or offset voltage of the amplifier is set by the upper output of the same string, some care is needed when adjusting either voltage so as not to disturb the other. The amplifier offset should be kept as close to +0.5 volts (or 2.5 volts) as possible, to ensure proper amplifier operation (i.e., balanced clipping of the signal). Thus, the series value of R8 and R9 should always be the same as that of R5.

If the comparator threshold is very close to the amplifier offset, very low-level sounds will be "digitized" by the comparator and make their way to the VCP200's input. That would permit better

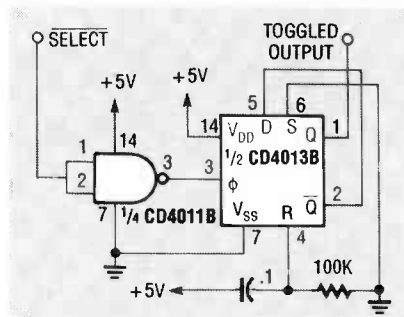

FIG. 8—TOGGLED, LATCHING interface circuit. The output switches states on successive occurrences of the associated voice command.

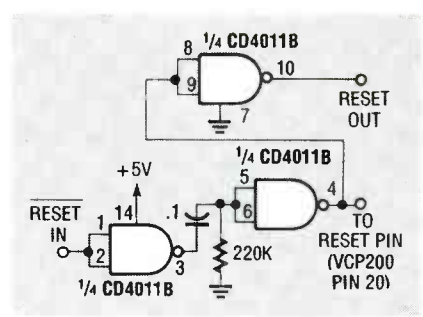
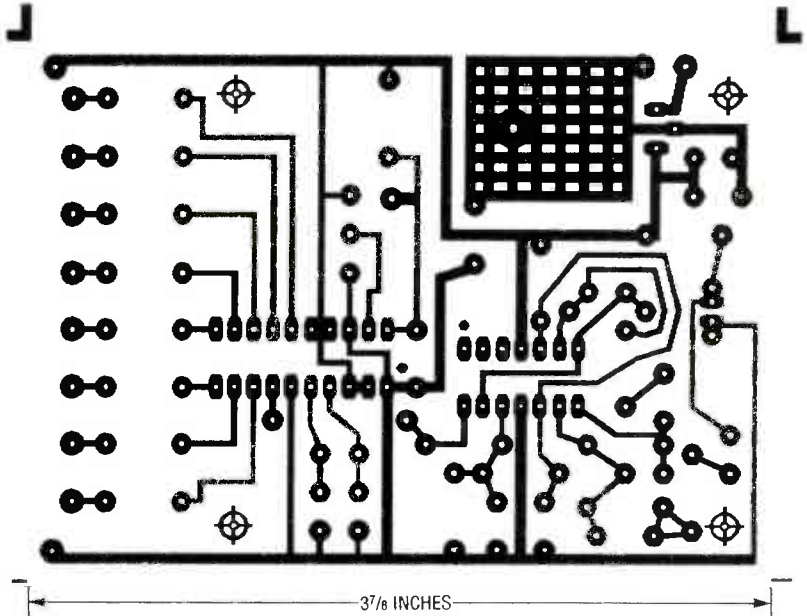

FIG. 9—THIS CONTROL CIRCUIT allows the project to be latched into forward or reverse motion while permitting other voice commands to be processed.



HERE'S THE FOIL PATTERN for the experimenter's version of the circuit, which includes the indicator LED's.

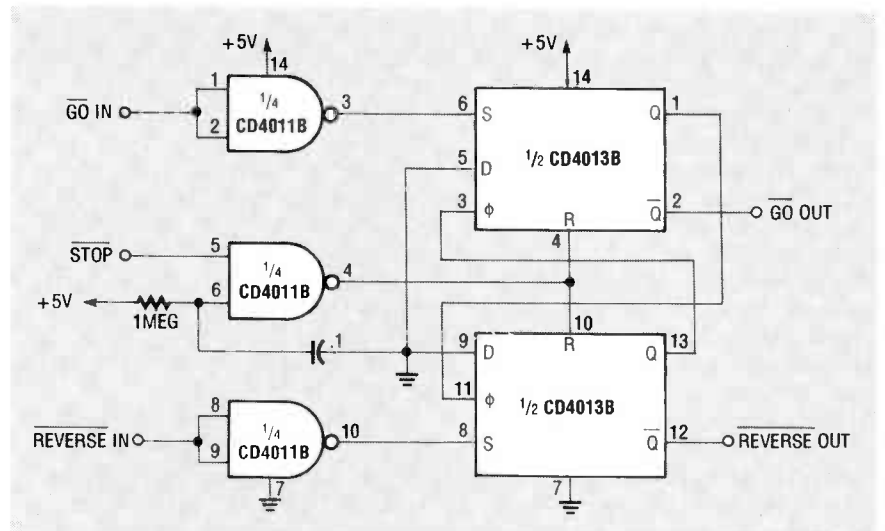

FIG. 10—A "SUICIDE" RESET CIRCUIT permits the voice-recognition circuit to be reset via voice command.

operation over distance or with softly-speaking users, but would make the unit prone to interference from noise. If the comparator threshold is set further

from the amplifier offset, noise will be rejected but louder speech or shorter-range operation will be required. For extensive experi-

continued on page 70

THE ADVANTAGES OF REGULATED switching power supplies are too great to ignore. These versatile supplies are well known for their high efficiency, cool operation, small size, and the ability to work with a wider range of input voltages than their linear counterparts. Once limited to high-power or high-efficiency applications, they are now finding their way into low-power, low-cost consumer goods.

Because the control elements used in switching regulators are always either fully on or fully off, they have low power consumption and require little or no heat sinking. Small-size high-frequency transformers can be used, and, since regulation efficiency is not too affected by the input-to-output voltage differential, it's possible to handle two-to-one input variations, such as 115/230 volt operation.

Switching regulators do, however, have disadvantages. A primary drawback is their complexity, and therefore circuit cost. They also exhibit failure modes not seen in simple linear regulators, and can radiate substantial electromagnetic interference (EMI) if not properly designed. Fortunately, a number of IC's have been developed that not only include most of the complex circuitry, but also overcome common failure modes, which we'll look at later. Now we'll concentrate on basics.

Switching regulator basics

Let's begin by reviewing a linear (non-switching) regulator as shown in Fig. 1. Op-Amp IC1 compares feedback voltage V_{FB} to reference voltage V_{REF} . If V_{FB} is too high, Q1's base voltage decreases or, if it's too low, the base voltage increases, until V_{FB} equals V_{REF} . At equilibrium, Q1's emitter-collector voltage drop equals $V_{UNREG} - V_{REG}$. The transistor power dissipation, W , equals $(V_{UNREG} - V_{REG}) \times I$.

A well-designed linear regulator can provide excellent regulation and transient response.

low noise and ripple, and complete freedom from EMI. It does, however, waste power in the regulating transistor, especially at high load currents. Regulating widely-varying inputs is a problem because power dissipation increases as V_{UNREG} goes up.

Now let's look at how pulse-width modulation (PWM) controls voltage. As shown in Fig. 2, Q1 is alternately turned on and off by the PWM control circuitry. The output is R-C filtered to obtain a DC average. If Q1 is always off, the output voltage will be zero; if it is always on, the output will equal the input. The output voltage will be proportional to the duty cycle, which is the ratio of the "on" time to the total period.

$$V_{OUT} = V_{IN} \times (T_{ON} / T_{TOTAL}) \\ = V_{IN} \times \text{Duty Cycle}$$

If Q1 were ideal (no voltage drop in the on state) it would dissipate

no power. Actual voltage drop varies depending on the transistor and the current level, but is usually less than or equal to one volt. (Power FET's respond better in high-current applications.) Power dissipation still occurs in filter resistor R1, reducing overall circuit efficiency.

Practical circuits

To reduce resistive power losses, switching regulators use L-C, rather than R-C filters, as shown in Fig. 3. When Q1 is on, V_{UNREG} is applied to inductor L1 and D1 is reverse-biased. The inductive current supplies the load and also charges output capacitor C2.

When Q1 turns off, the inductive current continues, flowing through D1. The diode conducts until the inductor current reduces to zero, or until Q1 is again turned on, whichever occurs

Inside SWITCHING POWER SUPPLIES

HARRY L. TRIETLEY

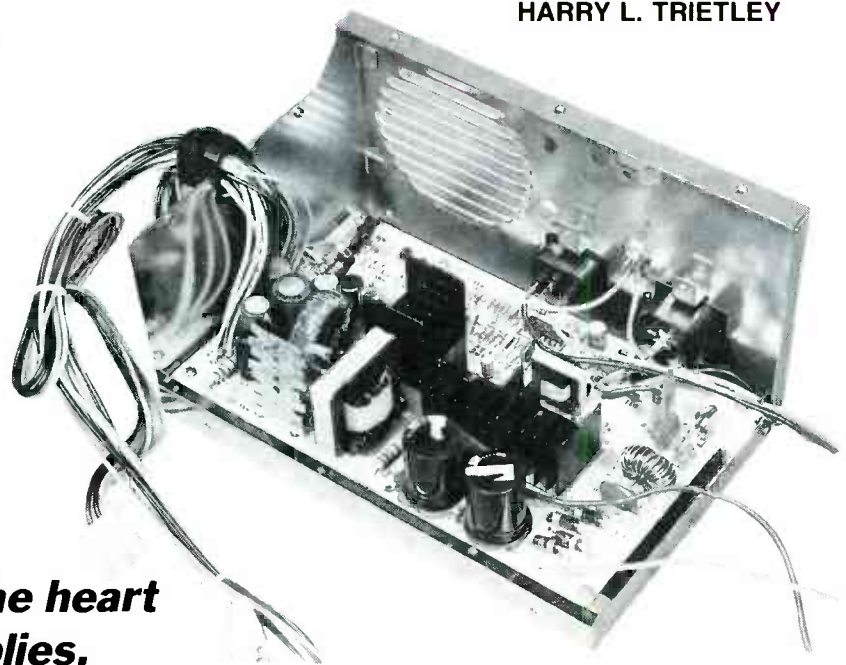

Learn the basics of switching regulators—the heart of switching power supplies.

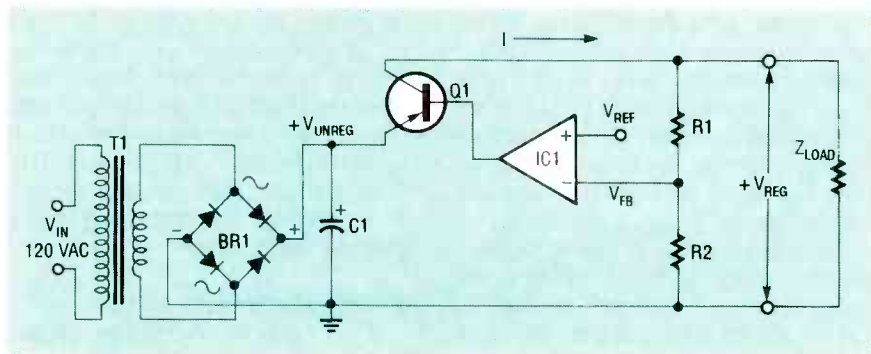

FIG. 1—A LINEAR REGULATOR CONTROLS conduction through a regulating transistor to maintain the required output.

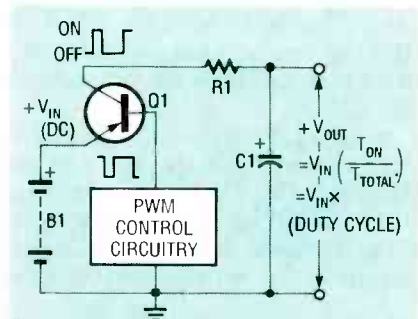

FIG. 2—PULSE WIDTH MODULATION (PWM) produces an output proportional to the duty cycle.

first. Inductor L1 smooths the on-off current from Q1, while C2 further evens out the load voltage. Complex switching-regulator control circuitry varies the duty cycle to keep the feedback voltage equal to the reference voltage. A circuit of that type is commonly called a "buck" converter because it bucks, or reduces, the input voltage.

The output current is greater than the input current because the inductive current continues while Q1 is turned off. For an ideal circuit, the regulator would be 100% efficient, meaning ($V_{REG} \times I_{OUT}$) equals ($V_{UNREG} \times I_{IN}$). In reality, however, circuit efficiency is typically about 80%.

Figure 4 shows a flyback, or "boost" converter. It operates much like a TV flyback, but with feedback added to control the output voltage. When Q1 is on, an inductive current builds up in L1. When Q1 turns off, the inductive current flows through diode D1, into C2 and the load. Since L1 is supplying current, its output side is positive and its voltage adds to, or "boosts" V_{UNREG} . The output voltage is, therefore, greater than the input voltage.

The longer Q1 is on, the higher the inductive current becomes. If

Q1's off time is not long enough to reduce the current to zero, it will build even higher during the next on cycle, raising the output even higher. Conversely, if the on time becomes very short, the circuit will act as if the input is connected directly to the output, and the output will equal the input (no boost). Mathematically, ignoring losses,

$$V_{REG} = V_{UNREG} / (1 - \text{Duty Cycle}).$$

As with the buck converter, feedback is used to control the duty cycle for the desired output. One thing to keep in mind when using a boost converter is that its input current can be much higher than its output current.

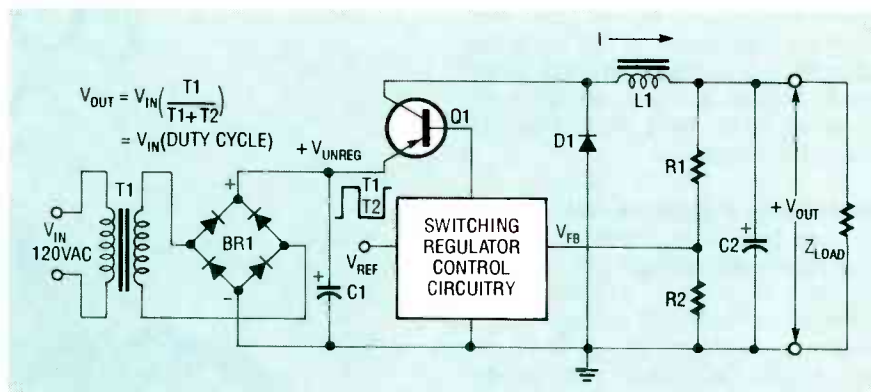

FIG. 3—MOST SWITCHING REGULATORS use L-C filtering to eliminate resistive power losses.

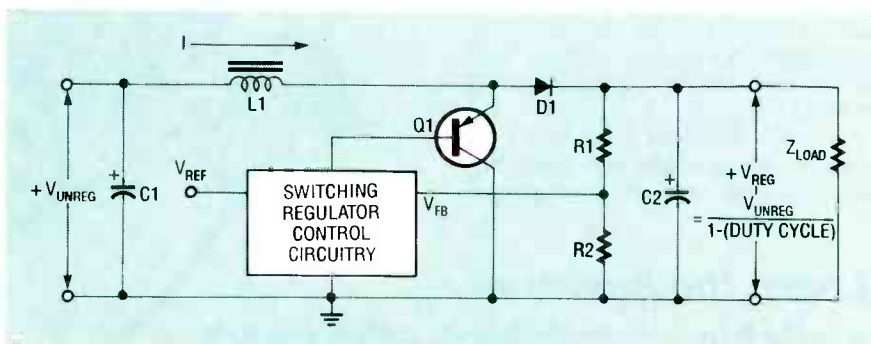

FIG. 4—A FLYBACK, OR "BOOST," converter produces an output voltage higher than its input.

The control circuitry

Let's get inside the control IC a little. To keep things simple, we'll leave out protective and problem-correcting circuitry and focus on the basic pulse-width control.

Figure 5 shows a typical circuit consisting of a clock (R-C oscillator), comparator, reference, error amplifier, flip-flop, output gate, and switching transistor. The error amplifier's output is proportional to the difference between the reference and feedback voltages. IC's vary greatly in detail, but generally use the principles discussed below.

At the beginning of each clock cycle a pulse resets the flip-flop, turning Q1 on, and the oscillator begins along the positive slope of the ramp. When the ramp exceeds the error signal, the comparator's output goes high, setting the flip-flop and turning Q1 off. The higher the error signal, the longer Q1 remains on.

The output voltage dividers in Figs. 3 and 4 are designed so that the feedback voltage, V_{FB} , equals the reference voltage, V_{REF} , when the output reaches the desired level. If the output voltage goes too high, the error voltage decreases, reducing the duty cycle

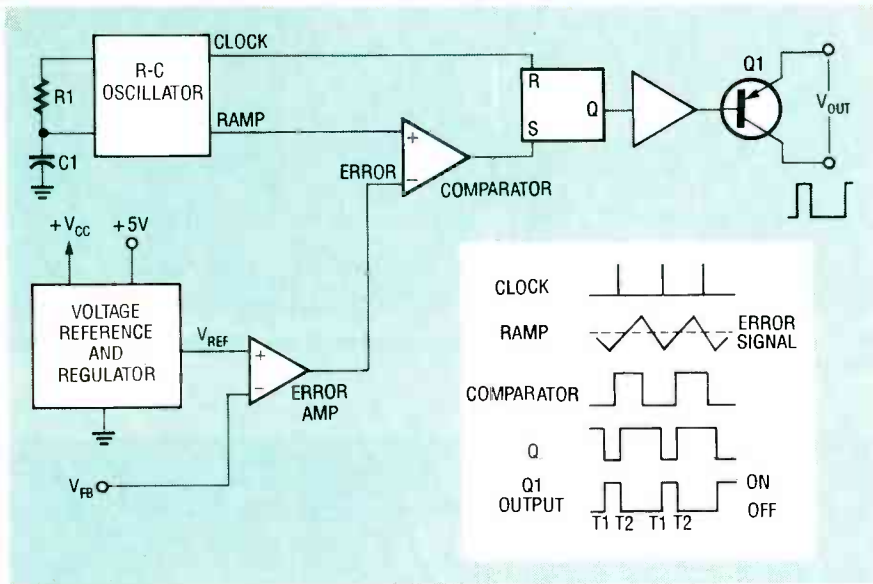

FIG. 5—THIS CIRCUIT SHOWS the heart of a pulse-width modulator, without its protective and problem-correcting circuitry.

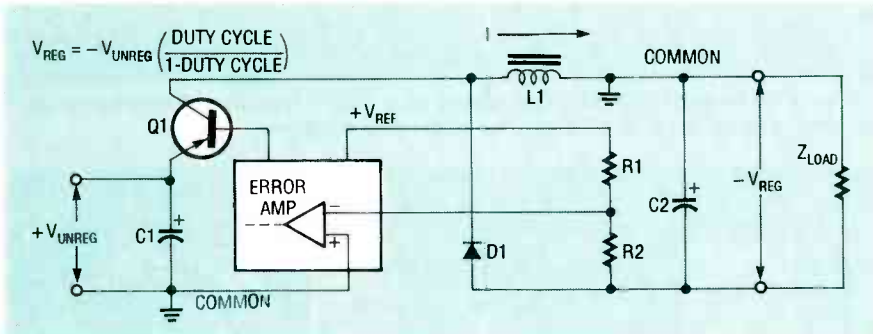

FIG. 6—A "BUCK-BOOST" CONVERTER produces a negative output from a positive input.

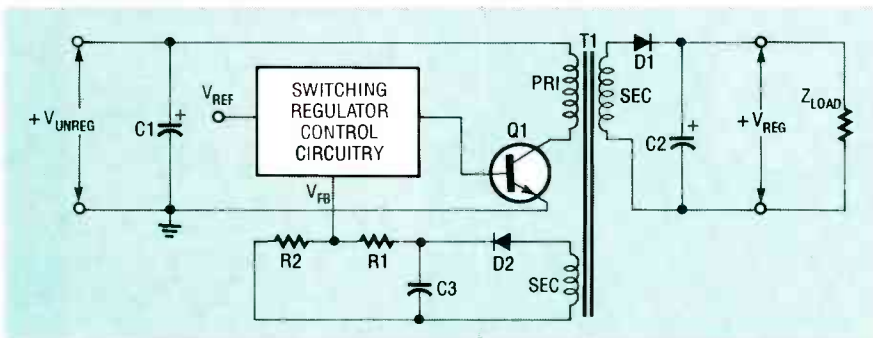

FIG. 7—IN A TRANSFORMER-COUPLED flyback converter a separate winding on the transformer allows output regulation while still maintaining input/output isolation.

cle and, therefore, the output. On the other hand, if the output voltage drops, the error voltage and duty cycle increases until the output returns to its design value. Now let's examine some more circuits and explore the differences between them.

A voltage inverter

Figure 6 shows a "buck-boost" converter which produces a

negative output from a positive input. That circuit is similar to the circuit shown in Fig. 3. In Fig. 6, however, the right side of the inductor is connected to common and the feedback network is different. The name "buck-boost" comes from the fact that the output can be lower or higher than the input.

When Q1 turns on, the input voltage is applied to inductor L1,

causing an increasing current. Unlike the "buck" regulator, that current does not flow through the load while Q1 is on. When Q1 turns off, the inductive current continues, flowing through D1 and charging output capacitor C2 with a negative voltage. The current continues until it reduces to zero, or until Q1 again turns on, whichever comes first. The longer the duty cycle, the higher the inductive current and, therefore, the higher the output voltage. The regulated output, V_{REG} , ignoring power losses, is

$$-V_{UNREG} \times [(Duty\ Cycle)/1 - (Duty\ Cycle)].$$

Transformer coupling

Up to this point, the circuits we've seen don't provide input-to-output isolation. They also suffer a second, less obvious shortcoming—an unbalanced current in the inductor, which produces a DC flux in the core, leading to saturation at lower power levels. Unbalanced operation of the power inductor requires larger, gapped cores to support the necessary magnetic fields. On the other hand, those circuits are simpler and use fewer components than the ones we're about to examine.

Primary-to-secondary isolation can be accomplished by using a transformer as shown in Fig. 3. High-power line-frequency transformers, though, are bulky and expensive. Since the pulse-width-modulation circuitry runs at high frequencies, it's often more efficient to transformer-couple and rectify its output pulses.

Figure 7 shows a simple transformer-coupled flyback converter. The control circuit is the same as in Fig. 4, but the inductor has been replaced with a flyback transformer. The on-time primary current builds up flux, which collapses when Q1 turns off. The collapsing field induces voltages in both secondaries, one of which produces the output while the other provides an isolated feedback voltage. Although this is a simple circuit, it still produces a net DC current in the transformer. The output voltage, V_{REG} , can be expressed as

$$V_{UNREG} \times N \times [(Duty\ cycle)/1 - (Duty\ Cycle)]$$

where N equals the transformer turns ratio.

A circuit known as a "forward

converter" (Fig. 8) is better suited for high-power supplies. When Q1 turns on, the unregulated input is applied to the first winding and D1 is reverse-biased. The primary current begins to rise and a voltage is induced in the output winding. Output current flows through D2 and L1.

When Q1 turns off, the collapsing field induces reverse-polarity voltages in all three windings. Since Q1 is off and D3 is reverse-biased, their windings carry no current. Current flows through the middle winding, known as a "reset" winding, and D2 becomes forward-biased. During that time the inductive current in L1 flows through D3.

As long as D2 conducts, the reset winding is connected to the input voltage. That condition continues until the current reduces to zero. There are two advantages of that circuit: the average primary current is zero, and the winding voltages are well-defined during the off portion of the cycle. A smaller core can be used, and high flyback voltages are not a problem. To maintain zero average current, the on time must never be longer than the off time, so the duty cycle is limited to 50%. The output voltage, V_{REG} , is

$$V_{UNREG} \times N \times \text{Duty Cycle.}$$

The output and input grounds are tied together in Fig. 8 for proper feedback voltage. To provide input-to-output isolation it is also necessary to isolate the feedback. We will discuss ways to do that in a future issue.

Finally, the push-pull circuit shown in Fig. 9 is similar to a DC-to-DC inverter, but with pulse-width modulation added. That circuit provides the best efficiency in high-power converters.

The primary winding's center tap is connected to V_{UNREG} . Transistors Q1 and Q2 are under the control of the switching regulator circuit. They are alternately pulsed on, connecting first one end of the primary and then the other to common. Raising the duty cycle increases the average applied voltage, and therefore the output voltage. Each transistor's duty cycle is limited to 50% (we must not have both turned on at once), but since there are two, the overall duty cycle can approach 100%. Again, isolated

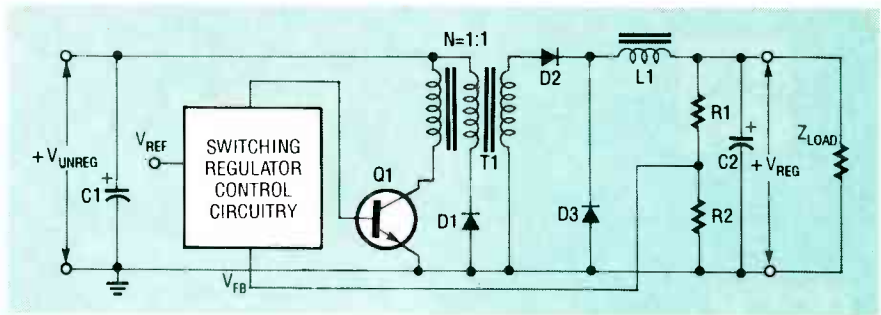

FIG. 8—IN A FORWARD CONVERTER direct-coupled feedback provides optimum regulation, but no input-output isolation.

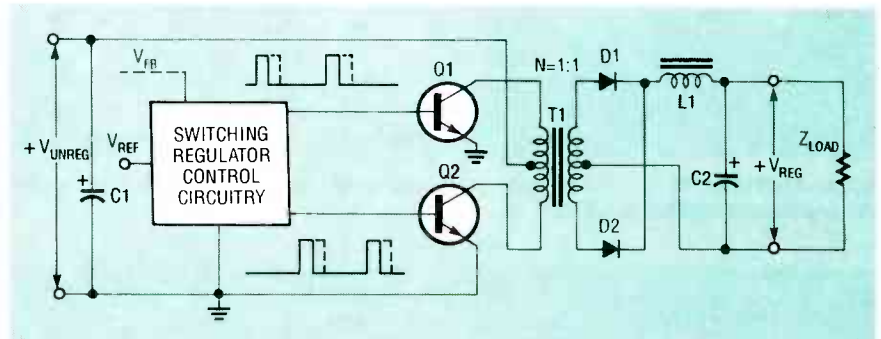

FIG. 9—A PUSH-PULL CONVERTER, similar to a DC-DC inverter but with pulse-width modulation, provides best efficiency for high-power supplies.

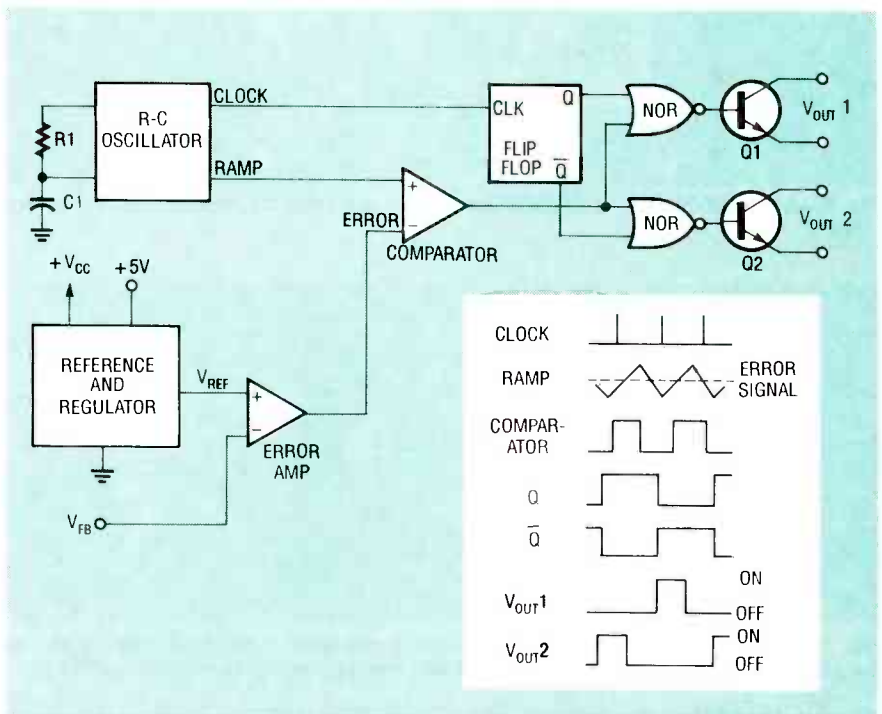

FIG. 10—ADDING A STEERING FLIP-FLOP and a pair of NOR gates produces a pulse-width modulator with push-pull output.

feedback is needed if input-to-output isolation is required. The output voltage, V_{REG} , is the same as the forward converter

$$V_{UNREG} \times N \times \text{Duty Cycle.}$$

Controlling the two transistors requires a change in the control circuitry, so let's examine the IC again. Figure 10 is similar to Fig.

5, with output-steering circuitry added. The clock pulses toggle the steering flip-flop. At the start of each cycle, when the comparator's output is low, the NOR gate whose Q input is low will turn on. The other remains off until the start of the next cycle toggles the flip-flop. Figure 10

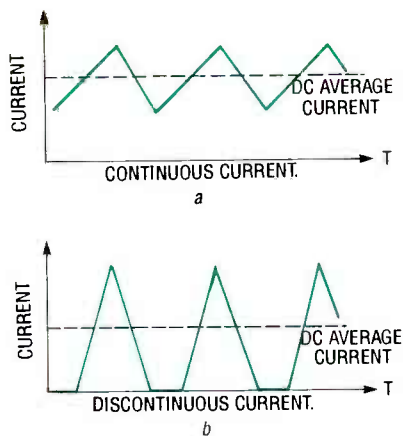

FIG. 11—CONTINUOUS (a) and discontinuous (b) inductor current.

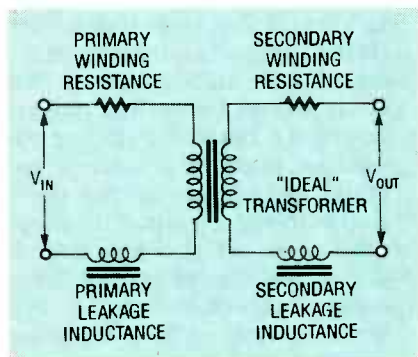

FIG. 12—A TRANSFORMER MODEL showing winding resistances and leakage inductances. Stray capacitances and core losses are not included.

shows the timing waveforms.

An IC of that type is very versatile, and can be used in all the circuits we have examined. Single-output control is implemented by simply paralleling Q1 and Q2. For forward converters, the 50% duty cycle limitation is easily provided by using only Q1 as the drive.

Which one should I use?

We have examined six circuits—three without transformers (buck, boost, and buck-boost) and three with (flyback, forward, and push-pull). Let's take some time now to compare the advantages and drawbacks of those techniques.

Transformer-coupled circuits are more flexible in stepping voltages up and down, and can provide input-to-output isolation. Negative outputs require only reversal of the rectifier diodes, and multiple secondaries can be used to provide multiple output voltages. The main drawback of transformer-coupled circuits is the cost, and the size of the trans-

former itself.

The choice among transformerless circuits is often simple. Use the buck circuit (Fig. 3) for voltage stepdown, where the output is lower than the input; the boost circuit (Fig. 4) for step-up; or the buck-boost circuit (Fig. 6) for polarity inversion. All three use the same number of components and have similar control requirements. One performance difference is worth noting: the buck converter tends to have lower output ripple because the inductor aids in filtering the output current.

When designing those circuits you must take into account the peak voltages and currents in the transistors and diodes to ensure that those components operate within their specified ratings. The buck converter operates with lower peak currents than the others, due to the filtering action of the inductor. Peak currents in the transistor and diode equal the output currents, while the peak voltages equal the input voltages.

In a boost converter, peak transistor and diode currents, I_{PK} , equal

$$I_{OUT} \times (V_{OUT}/V_{IN})$$

The peak voltage equals the output voltage.

In a buck-boost supply, the peak current, I_{PK} , equals

$$I_{OUT}/1\text{-Duty Cycle.}$$

The peak voltage equals the sum of the input and output voltages.

One drawback of the boost circuit should be mentioned. Because the input is directly connected to the output through the inductor and diode, it is not possible to use short-circuit limiting in the circuit.

The flyback converter (Fig. 7) retains the advantages (cost and simplicity) and drawbacks (high peak currents, high ripple, and DC coil current) of a transformer-coupled circuit. It's the best choice when a simple, low-cost circuit is needed to regulate up to tens of watts. Peak switch current, I_{PK} , of a flyback converter is

$$I_{OUT} \times (N \times V_{IN} + V_{OUT})/V_{IN}$$

Forward and push-pull converters (Figs 8. and 9) are best for regulating higher power, whether isolation is needed or not. Both require extra windings, inductors and circuitry, but both provide the transformer

with a balanced current. Also, both produce lower output-ripple current than the flyback. As a result, smaller transformers and filter components may be used. Input peak and output ripple currents are higher in the forward converter, because its duty cycle is limited to under 50%. Both are well-suited for use at tens to hundreds of watts, but for highest power (especially above 1000 watts) a push-pull converter should be chosen.

Discontinuous operation

For most efficient operation in any of the circuits we've discussed, the inductor current should flow continuously; otherwise, ripple currents will increase and regulation may suffer. That effect is most apparent in transformerless circuits. Those circuits depend on energy stored during the on cycle being transferred to the output when the transistor turns off. If the inductance is too low, all of its stored energy will be transferred to the output before the transistor turns back on.

Continuous operation results when the peak-to-peak ripple current in the inductor is less than twice the inductor's load, or DC average current: in other words, when the inductance is large enough that the negative excursion of its ripple never reaches zero. Figure 11-a shows continuous operation, while Fig. 11-b shows discontinuous operation. For example, in the buck converter of Fig. 3, continuous operation means that inductor current is always flowing into the load. Maintaining continuous operation in a switching regulator is usually a simple matter of choosing a large enough inductor.

Discontinuous operation normally occurs at low output loads, when the DC current is so low that the negative excursion cannot be kept above zero. Fortunately, discontinuous operation is not disastrous, only annoying, if it only happens under abnormally light loading. A decrease in regulation and increase in ripple are the usual result.

On the other hand, if the problem occurs under heavy loads due to poor design (improper in-

DIGITAL VIDEO STABILIZER ELIMINATES ALL VIDEO COPY PROTECTIONS



While watching rental movies, you will notice annoying periodic color darkening, color shift, unwanted lines, flashing or jagged edges. This is caused by the copy protection jamming signals embedded in the video tape, such as Macrovision copy protection. Digital Video Stabilizer: RXII completely eliminates all copy protections and jamming signals and brings you crystal clear pictures.

WARNING :
SCO Electronics and RXII dealers do not encourage people to use the Digital Video Stabilizer to duplicate rental movies or copyrighted video tapes. RXII is intended to stabilize and restore crystal clear picture quality for private home use only.

FEATURES:

- Easy to use and a snap to install
- State-of-the-art integrated circuit technology
- 100% automatic - no need for any troublesome adjustments
- Compatible to all types of VCRs and TVs
- The best and most exciting Video Stabilizer in the market
- Light weight (8 ounces) and Compact (1x3.5x5")
- Beautiful deluxe gift box
- Uses a standard 9 Volt battery which will last 1-2 years.

(Dealers Welcome)

To Order: \$49.95 ea + \$4 for FAST UPS SHIPPING
1-800-445-9285 OR **516-568-9850**
 Visa, M/C, COD M-F: 9-6 (battery not included)
 SCO ELECTRONICS INC.
 Dept. CRE4 581 W. Merrick Rd. Valley Stream NY 11580
 Unconditional 30 days Money Back Guarantee

CIRCLE 179 ON FREE INFORMATION CARD

CABLE TV DESCRAMBLER

How You Can Save Money
on Cable Rental Fees

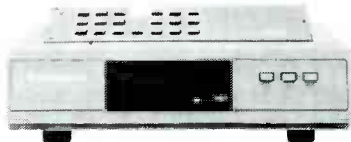

1 Unit 5+
 Jerrold SB w/Tri-Bi.....\$99...\$70
 Super-Tri-Bi (TBM).....\$109...\$75
 Jerrold 450 combo.....\$189...\$139
 Scientific Atlanta.....\$109...\$75
 SA 8536.....\$250...\$195
 Pioneer.....\$109...\$79
 Oak KN12 (w/VS).....\$109...\$65
 Hamlin MLD 1200.....\$89...\$59
 Tocom.....\$169...\$129
 Stargate converter.....\$89...\$69
 Panasonic TZPC145.....\$99...\$79

US Cable will Beat Anyone's Price Advertisd in this Magazine!

30 Days Money Back Guarantee
 Free 16 page Catalog

Visa, M/C, COD or send money order to:
US Cable TV Inc. Dept. KRE4

4100 N. Powerline Rd., Bldg F-4
 Pompano Beach, FL 33073

1-800-445-9285

For Our Record

I, the undersigned, do hereby declare under penalty of perjury that all products purchased, now and in the future, will only be used on Cable TV systems with proper authorization from local officials or cable company officials in accordance with all applicable federal and state laws. FEDERAL AND VARIOUS STATE LAWS PROVIDE FOR SUBSTANTIAL CRIMINAL AND CIVIL PENALTIES FOR UNAUTHORIZED USE.
 Date: _____

Signed: _____

No Florida Sales!

CIRCLE 180 ON FREE INFORMATION CARD

ductor selection) the result may be core saturation, excessive current spikes and destruction of components such as the switching transistor.

Inductors and transformers

Let's finish our discussion by looking at inductors and transformers. The design of switching-regulator magnetics is a complex subject which we cannot cover completely in this article. We will, however, briefly discuss some of the more important concepts such as physical size, construction, ratings, and leakage inductance.

Our first consideration is size. The inductance of a choke or transformer must be large enough to keep ripple current within acceptable bounds and to maintain continuous operation. The core must not saturate at its highest current. Some of the design tradeoffs include size, power, filtering and transient response. Larger inductances and cores provide highest power and lowest ripple, but with slow recovery from transients.

Cores should be a ferrite material or powdered iron—laminations are not suitable for high-frequency operation. Toroidal cores minimize EMI because they tend to be self-shielding. Air gaps usually are needed to prevent saturation with unbalanced DC currents. The gap reduces the core's permeability, requiring larger structures to achieve the required inductance. When buying an inductor or transformer make sure it is rated for the frequencies and DC currents you will be applying to it. The affect of saturation could be the destruction of switching transistors, control IC's or other components in the circuit.

An approximate inductance value can be calculated from basic inductor theory. Inductor current increases linearly with time when a DC voltage is applied

$$\Delta I = E \times T / L$$

where ΔI is the change in current in amps, E is the applied voltage in volts, T is time in seconds, and L is inductance in henrys.

If your circuit operates at a frequency in hertz equal to $1/T$, the maximum voltage across the inductor is E and you want to design for a peak-to-peak ripple

current of ΔI , the inductor value can be found by

$$L = E / 2(\Delta I) f$$

It's best to start with a little extra inductance, then optimize it experimentally. Inductor values in the medium to high microhenries are common.

Switching regulators operate at high frequencies and fast risetimes, and switching transients can produce peak voltages higher than the values given earlier. Transformers with switched primary currents are the main source of that problem.

A major source of primary-side spikes is leakage inductance. Figure 12 shows a transformer model including winding resistances and leakage inductances. (Winding capacitances are not shown.) In an ideal transformer there would be perfect magnetic coupling between the primary and secondary. A voltage spike could not appear across the primary unless a proportional spike was seen on the secondary. If there was a load across the secondary, especially when a capacitor is used, spikes would not occur.

In reality, a small portion of the flux produced by the primary is not coupled to the secondary. Electrically, that means that a small part of the primary's inductance is not coupled to the secondary, and vice-versa. Transformer leakage inductance is represented in Fig. 12. Switched primary currents produce spikes in the leakage inductance.

Leakage inductance can be minimized, but not completely eliminated, by proper transformer design. The best approach is a bifilar winding, where the primary and secondary are wound together, their wires intermixed in the same coil. That may not be possible in transformers requiring high primary-to-secondary breakdown voltages. It's sometimes necessary to add Zener diodes and/or small capacitors, across the primary to protect the switching transistors and diodes.

In the second and final part of this article, we'll look at some more protective and safeguard circuitry provided in switching regulator IC's. We'll also examine some IC families with which you should be familiar.

R-E

PEOPLE TEND TO THINK OF ROBOTS as complex, expensive creatures designed to execute boring, repetitive tasks, day in and day out, for eternity. And sure, there are industrial robots that work like that. But not all robots are boring drudges. In fact, it's possible to build an inexpensive experimental robot that will perform non-repetitive tasks under program control.

Our robot is called Ken. He's easy to build and fun to program; and in so doing you can learn a great deal about important issues in robotics. Ken is a two-wheeled, battery-powered, free-roaming, obstacle-avoiding robot. Ken's intelligence consists of a single-component microcontroller; his propulsion is provided by two stepper motors driven by a single high-current IC driver. All together, Ken's electrical system consists of eleven electronic and five electro-mechanical devices. (By the way, Ken is not an abbreviation for anything in particular; the author simply thought that it would be rather nice to give the robot some personality.)

Theory of operation

Ken was designed to move freely on a smooth, flat surface. Using the specified stepper motors (or others with a higher torque rating), Ken rolls easily on a tile floor or tight-napped carpet. He has a low center of gravity and is equipped with two oppositely opposed wheels, each driven by a stepper motor. The edge of Ken's smooth plastic case serves as the third point of contact with the floor.

Ken's schematic is shown in Fig. 1. All of his nomadic habits are dictated by IC1, an 8748H microcontroller, that is packaged in a standard 0.6-inch, 40-pin package. In addition to the CPU, the 8748H includes 1024 bytes of EPROM, 64 bytes of RAM, 24 bits of I/O, a crystal oscillator, and an eight-bit timer/counter. For our purposes, we configured IC1 for one 8-bit output port to drive IC2, and one 8-bit input port to monitor motion-sensing switches S2 and S3. Note that Ken doesn't take advantage of all the 8748H's resources, and that leaves you with lots of possibilities for expansion.

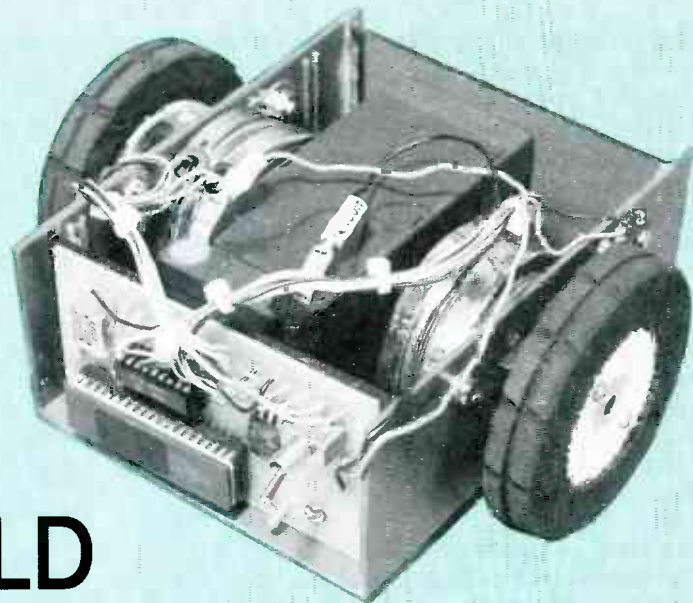

BUILD THE STEPPER-MOTOR ROBOT

FRED EADY

Ken, the friendly robot, is fashioned around an 8748 microcontroller. Build him for less than \$100!

Crystal XTAL1 drives the 8748H's internal oscillator; the value of XTAL1 may range anywhere from 1 to 11 MHz. Capacitors C3 and C4 help to start and stabilize the oscillator. However, the author has found that the 8748H will operate reliably without them. Capacitor C1 is used to reset IC1.

Under program control, eight of IC1's I/O ports drive IC2, a ULN2803 high-voltage, high-current octal Darlington transistor array. The ULN2803 can drive a total of eight 500-mA loads with as much as 50-volts DC per load. The ULN2803 has built-in clamp diodes that help suppress stepper-motor noise. ULN2803's can be "stacked" by wiring several of them in parallel. Although doing so was unnecessary for our prototype, you may wish to if you use high-current steppers. Ken's steppers have 12-volt windings that draw approximately 300 mA per winding.

Stepper motor theory

A stepper motor converts electrical pulses into rotational motion. As shown in Fig. 2, a typical stepper motor consists of a permanent-magnet (PM) motor built around two stator cups, with each cup surrounding a separate stator winding. The stator cups form pole pairs that are mechanically displaced by $\frac{1}{2}$ a pole pitch. However, the stator-cup winding pairs displace each other by only $\frac{1}{4}$ a pole pitch. When the stator windings are energized, the pole pairs are energized in alternation, thus creating North and South magnetic poles. The PM rotor is magnetized, so it aligns on the pole pairs provided by the stator cups.

By changing the polarity of the voltage applied to the stator windings, it is possible to force the rotor to move $\frac{1}{4}$ a pole pitch. The change in polarity causes opposite poles to attract and like poles to repel, thereby compelling

the PM rotor to realign. That realignment is the source of the output shaft's rotational motion. Ken's motors contain 12 pole pairs per stator-winding section, and thus take 48 steps for a complete revolution (7.5 degrees/step).

Alternately energizing each winding in a predetermined pattern moves the rotor continually in one direction. You can run the pattern backward to reverse rotor motion. Speed of rotation is determined by the rate at which the pattern runs. The standard pattern for Ken's stepper motors is shown in Fig. 3.

Now that we know what drives the steppers, let's take a look at how to drive them.

Stepper-motor driver circuit

Figure 4 shows the schematic of a unipolar stepper motor with associated drive transistors. Note that four coils are shown. Each winding consists of two coils wound on the same bobbin per stator half. (By contrast, Fig. 2 depicts a two-coil or "bipolar" stepper.)

You can reverse stator flux in a bipolar motor by reversing the current in the coil. However, doing so requires twice as many drive transistors as a unipolar motor. In addition, as Fig. 5 shows, you must ensure that the circuit does not turn on a series-connected pair of transistors (Q1 and Q2, for example), which would in turn short the power supply.

By contrast, unipolar flux may be reversed by energizing either one coil or the other using a single-ended power supply. In addition, using unipolar motors eliminates the need for extra drive transistors and eliminates the possibility of accidentally shorting the power supply.

As stated earlier, steppers convert electrical pulses into rotational motion. One excellent source of electrical pulses is the output port of our 8748H microcontroller. If one were to equate "on" in Fig. 3 to a binary "1," and "off" to a binary "0," and then apply the pattern to the driver transistors via the microcontroller's output port, the output shaft of the stepper motor would rotate. It's that simple. Unfortunately, we don't have space

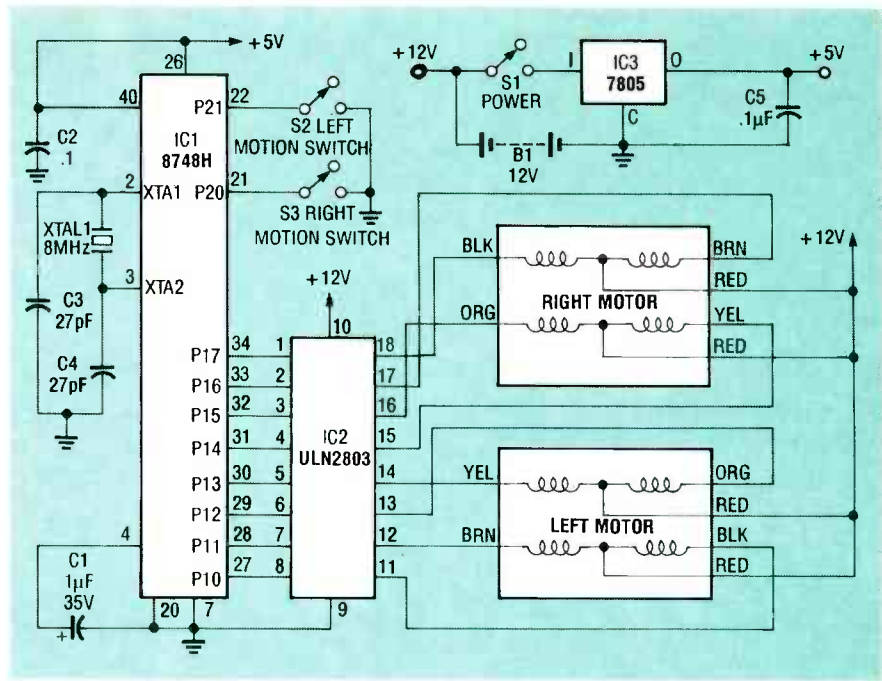

FIG. 1—SCHEMATIC DIAGRAM. Intelligence is provided by IC1, an 8748 single-chip microcontroller.

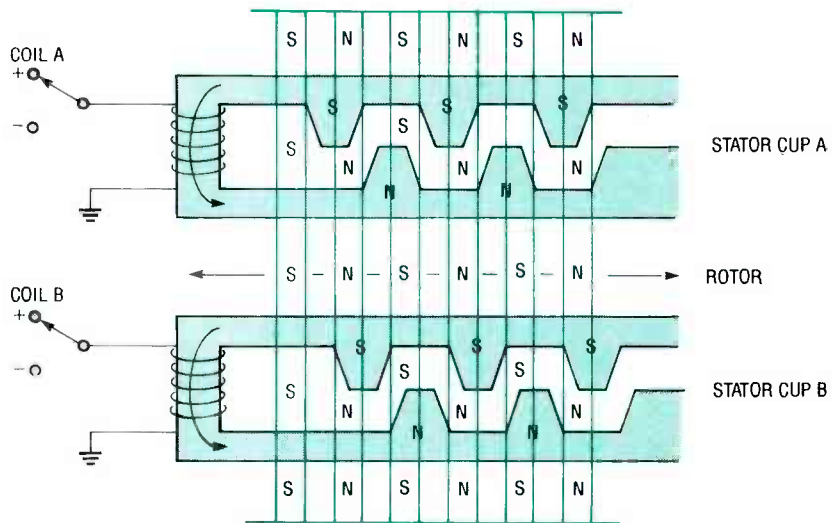

FIG. 2—MECHANICAL DIAGRAM showing the parts of a bipolar stepper motor.

to print the software listing here, but it's available on the RE-BBS (516-293-2283, 300/1200, 8N1, filename: ROBOT.ASM), and from the source mentioned in the parts list.

How Ken maneuvers

Now we understand how Ken moves, but there's still one problem: What if he runs into something? (Earlier we stated that Ken is an obstacle-avoiding robot, but that's not entirely accurate. Ken doesn't really avoid things—he runs into them first!) When Ken confronts an obstinate object, one or both of his wheels will stop. As shown in Fig. 6, the

	STEP	Q1	Q2	Q3	Q4	
CW ROTATION ↓	1	ON	OFF	ON	OFF	↑ CCW ROTATION
	2	ON	OFF	OFF	ON	
	3	OFF	ON	OFF	ON	
	4	OFF	ON	ON	OFF	
	1	ON	OFF	ON	OFF	

FIG. 3—ENERGIZING SEQUENCE for clockwise and counterclockwise motion.

hub of each wheel has two large screws, the heads of which function as cams. As the wheel rotates, one "cam" actuates the associated microswitch every 24 steps (1/2 revolution). If one of the switches fails to toggle after 24

PARTS LIST

Capacitors

C1—1 μ F, 35 volts, tantalum
 C2, C5—0.1 μ F, disk
 C3, C4—27 pF, disk

Semiconductors

IC1—8748H microcontroller
 IC2—ULN2803 octal driver
 IC3—7805 +5-volt regulator

Other components

B1—12-volt, 1.2 amp-hour gel cell
 M1, M2—stepper motor (All Electronics SMT-5, or Airpax A82743-M4)
 S1—SPDT toggle switch
 S2, S3—SPDT microswitch (All Electronics SMS-90 or equivalent)
 XTAL1—8-MHz crystal

Miscellaneous: Heatsink for IC2, case (Radio Shack 270-224 or equivalent), lettuce crisper, brass tubing, rubber tires, PC board, wire, solder, etc.

Note: A kit of electronic parts, not including the case and stepper motors, is available for \$39 plus \$2 shipping from Fred Eady, 1217 McDonald Street, Fayetteville, TN 37334.

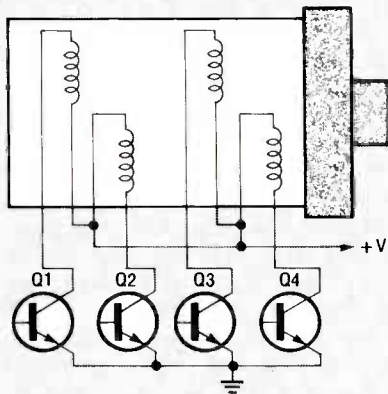

FIG. 4—WIRING DIAGRAM for a unipolar stepper motor.

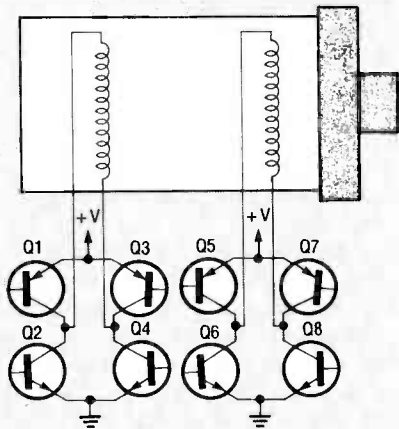

FIG. 5—WIRING DIAGRAM for a bipolar stepper motor. If a series-connected pair of transistors were turned on simultaneously, the power supply would be shorted.

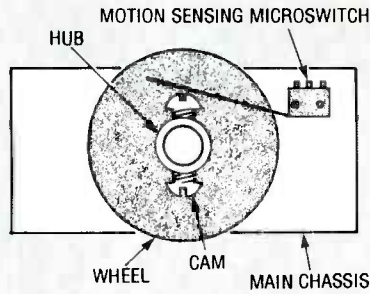

FIG. 6—WHEEL ASSEMBLIES. Two roundhead screws function as cams that actuate the microswitch every half revolution.

step commands from the 8748H, Ken determines that the corresponding wheel has stopped, thus reinforcing the law of physics that states that an object in motion continues in motion until it is interrupted by some external force. Ken, a law-abiding physics student, will then back up and attempt to go around the obstacle.

Ken and Sir Isaac

We know that Ken is intelligent and likes to travel in free space—but how does he do it? Ken's secret is linear force developed by the wheels, which in turn is derived from torque provided by the stepper motors. How do we know how much force is required to move Ken? Mr. Newton put it simply: $F = ma$, or force equals mass times the acceleration necessary to move that mass.

Ken weighs in at about four pounds; his wheels have a 1.5-

inch radius. Taking an arbitrary acceleration of 2 ft./sec², let's calculate the force required to move Ken forward at that rate. First, we must convert four pounds to mass by dividing the weight by 1 "g" (32.2 ft./sec²), leaving 0.124 slug (mass is measured in slugs).

Using our formula, $F = ma = 0.124 \text{ slug} \times 2.00 \text{ ft./sec}^2 = 0.248$ pounds of force to move Ken at 2 ft./sec². The rated holding torque of the stepper motor used in Ken is 10.5 ounce-inches. (If you use a different motor, torque may vary.) That value is stated on the motor's data sheet and is determined when the rated DC current is flowing continuously through two of the motor's four windings. Using the formula $F = T/r$ (where F is linear force, T is holding torque, and r is wheel radius), we conclude that $F = T/r = 10.5 \text{ ounce-inches} / 1.5 \text{ inches}$, or 7 ounces per wheel. Ken is a two-wheeled creature, so a total of 14 ounces, or 0.875 pounds, of linear force is generated. That's plenty of power (since Ken needs only 0.248 pounds of force), but as with all steppers you lose some force when the motor is rotating.

So, looking again at the data sheet, let's derate the torque by assuming we will be sending 100 pulses per second to the steppers. Doing so derates the maximum torque value by almost 50% and equates to 5.67 ounce-inches of torque. Plugging that value into our formula for linear

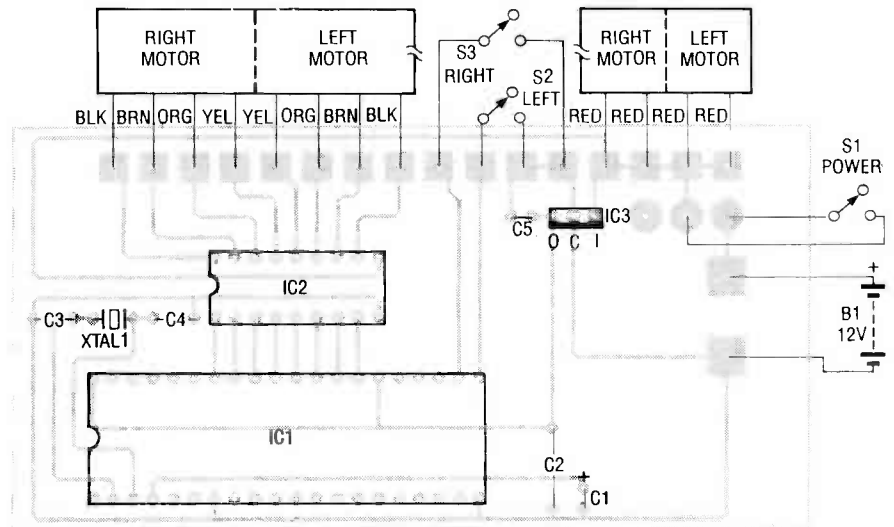

FIG. 7—MOUNT ALL PARTS as shown here. If you use motors other than those specified, you may have to experiment to determine which windings connect to which outputs of IC2.

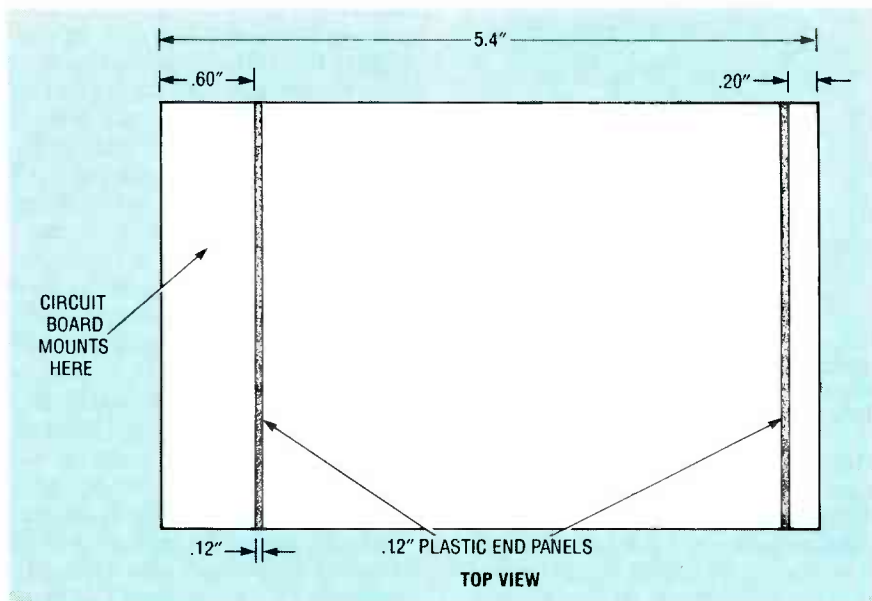

FIG. 8—TOP VIEW. Remove the front and rear ends of the case and glue end panels in place as shown.

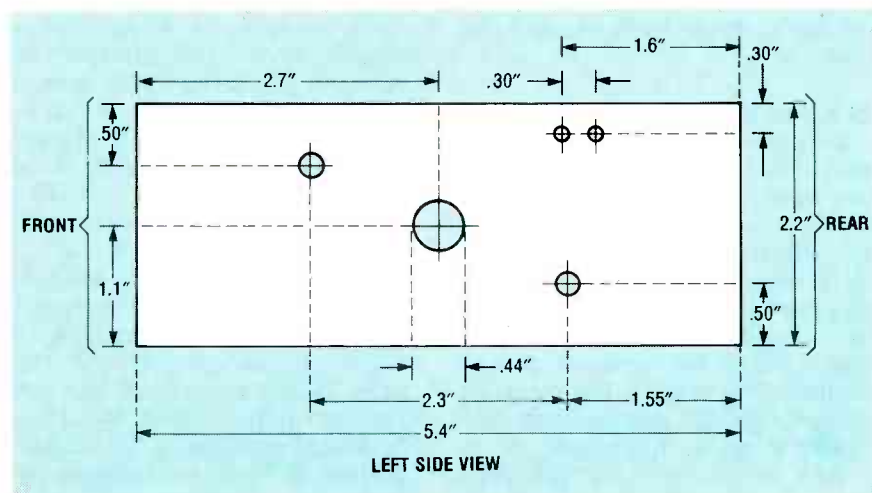

FIG. 9—LEFT SIDE VIEW. The right side is a mirror image.

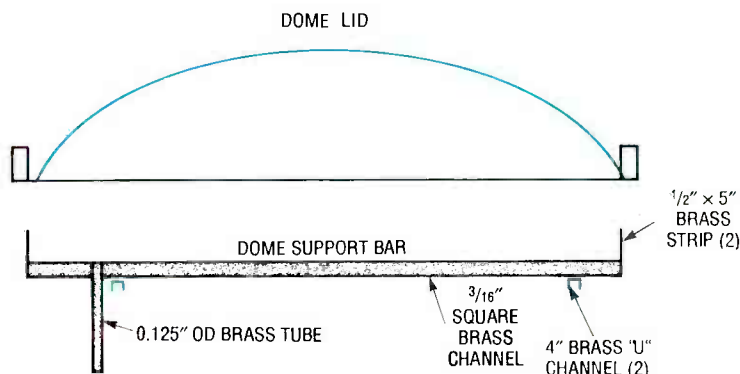

FIG. 10—THE COVER SUPPORT is built from brass channels. Exact dimensions will vary, depending on your cover.

force, we find the result to be 0.473 pounds of linear force, still more than enough.

Enough of this theoretical stuff, let's roll up our sleeves and build Ken.

Electronic assembly

A single-sided PC board allows for convenient construction. Foil patterns are provided, although an etched and drilled board is available.



FIG. 11—KEN IS SHOWN HERE with his cover removed.

Using the parts layout shown in Fig. 7 as a guide, mount all electronic components. Put a thin coat of heatsink compound on the top and bottom surfaces of IC2, and then slide on a heat-sink. Double-check the parts orientation and all solder joints before continuing.

Next connect the stepper motors and microswitches. If you use surplus steppers and cannot determine which winding is which, check the advertisement for an ohms-per-winding value. You can then determine which wires represent independent windings by measuring resistance between various pairs of wires. After you determine which pairs correspond to windings, use trial and error to determine how they should be connected to the PC board. With only four windings, it shouldn't take long to find the right combination.

Mechanical assembly

Ken is built from plastic and brass, although you can use any materials you like. However, if you deviate from our specifications, be sure to recalculate the amount of force required to move your robot and select steppers accordingly.

The body of the prototype consists of a plastic instrument case obtained from a local electronics retailer. That case was selected because it was wide enough to hold both the steppers and B1, a gel cell. We cut off the ends of the case to form a U-shaped channel, and later glued clear red acrylic panels along slots designed for mounting a PC board. You can glue the panels in place using

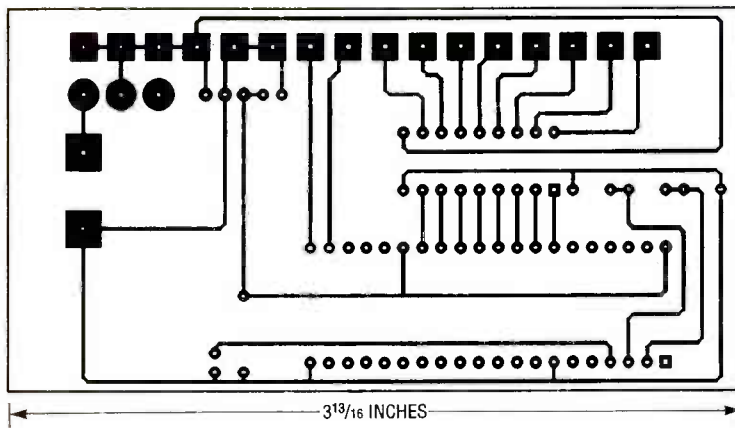

FOIL PATTERN for Ken's controller board.

modeling cement. The thickness of the panels matches the width of the brass U-channels, discussed below.

Begin assembly by forming and drilling the main body, as shown in Figs. 8 and 9. Next, mount the stepper motors and install the wheels. The wheels may come from inexpensive toys; the author has seen suitable wheels on toys costing less than four dollars. Be sure that the wheels fit the stepper-motor shafts, and that the diameter of the wheels is large enough to raise Ken's body off the floor. Also, use brass or aluminum tubing to shim the stepper-motor shafts, if necessary. In addition, be sure that you can screw or glue some sort of cam surface to the hubs of the wheels to sense wheel motion. The author used oversized set screws for cams.

After mounting the stepper motors and wheels, fit the motion-sensing switches, S1 and S2. Using an ohmmeter to measure continuity, adjust each microswitch to actuate on the high point of the cam surface.

Cover construction

We built a transparent cover for the prototype. (The cover is optional.) We used a lettuce crisper from a local discount department store. First we removed the bottom half of the body, leaving a ring about two inches high. We attached the ring to the domed top of the crisper with a couple of pop rivets. We also custom-built a brass support bar that fits inside the assembly and allows it to rest on Ken's body. Feel free to improvise on our design, but remember to keep the weight down. Also, to provide access to

the battery, the cover should not be permanently mounted to the body.

As shown in Fig. 10, the all-brass cover support consists of a long support bar, two thin strips that hold the bar in the lip of the dome, two "U" channels that slip on the end plates of the body, and a vertical tube for stability. Use solder for all mechanical connections. Figure 11 shows Ken with his cover in place.

Final assembly

After checking all connections, connect a 12-volt gel cell to Ken and power him up. Both wheels should turn in the same direction until you stop one (or both). In either case, Ken should reverse both wheels and perform a turn by rotating the wheels in opposite directions. After performing the turn sequence, Ken should again rotate both wheels in the same direction. Also, Ken should turn in opposite directions, depending on which wheel you stop.

Ken in the big world

It's time for Ken's maiden voyage. Just turn him on and let him go. As soon as he runs into something, he should attempt to change direction. Ken is always very busy, and cats love him.

Ken is a simple robot, but the principles of operation are identical to those of large (and expensive!) robots. You can take the basic building blocks presented here and expand on them to build a large and sophisticated device. Have fun, and remember, all of Ken's "intelligence" is under software control. If you don't like the way something works—change it!

R-E

Earn Your B.S. Degree in ELECTRONICS or COMPUTERS



By Studying at Home

Grantham College of Engineering, now in our 41st year, is highly experienced in "distance education"—teaching by correspondence—through printed materials, computer materials, fax, and phone.

No commuting to class. Study at your own pace, while continuing on your present job. Learn from easy-to-understand but complete and thorough lesson materials, with additional help from our instructors.

Our Computer B.S. Degree Program includes courses in the BASIC, PASCAL, and C languages — as well as Assembly Language, MS DOS, CADD, and more.

Our Electronics B.S. Degree Program includes courses in Solid-State Circuit Analysis and Design, Control Systems, Robotics, Analog/Digital Communications, and more.

An important part of being prepared to *move up* is holding the right college degree, and the absolutely necessary part is knowing your field. Grantham can help you both ways—to learn more and to earn your degree in the process.

Write or phone for our free catalog. Toll free, 1-800-955-2527, or see mailing address below.

Accredited by
the Accrediting Commission of the
National Home Study Council

GRANTHAM
College of Engineering
Grantham College Road
Slidell, LA 70460

ATTENTION! ELECTRONICS TECHNICIANS

EARN YOUR
**B.S.E.E.
DEGREE**

THROUGH HOME STUDY

Our New and Highly Effective Advanced-Placement Program for experienced Electronic Technicians grants credit for previous Schooling and Professional Experience, and can greatly reduce the time required to complete Program and reach graduation. No residence schooling required for qualified Electronic Technicians. Through this Special Program you can pull all of the loose ends of your electronics background together and earn your B.S.E.E. Degree. Upgrade your status and pay to the Engineering Level. Advance Rapidly! Many finish in 12 months or less. Students and graduates in all 50 States and throughout the World. Established Over 40 Years! Write for free Descriptive Literature.

COOK'S INSTITUTE
OF ELECTRONICS ENGINEERING



4251 CYPRESS DRIVE
JACKSON, MISSISSIPPI 39212

CIRCLE 58 ON FREE INFORMATION CARD

JAN CRYSTALS

*your reliable source for
a world of crystal clear
communication*



- Commercial Two-Way
- MicroProcessors
- Amateur/Experimental
- Scanners/Monitors/Pagers
- Satellite-Telemetry
- Plus custom applications

EXPEDITED ORDER SERVICE!

FOR FREE CATALOG,
CALL OR WRITE:

JAN CRYSTALS

P.O. Box 06017
Ft. Myers, FL 33906
(813) 936-2397



TOLL FREE 1-800-526-9825

FAX ORDERS: 1-813-936-3750

CIRCLE 104 ON FREE INFORMATION CARD

POWER INVERTER

continued from page 44

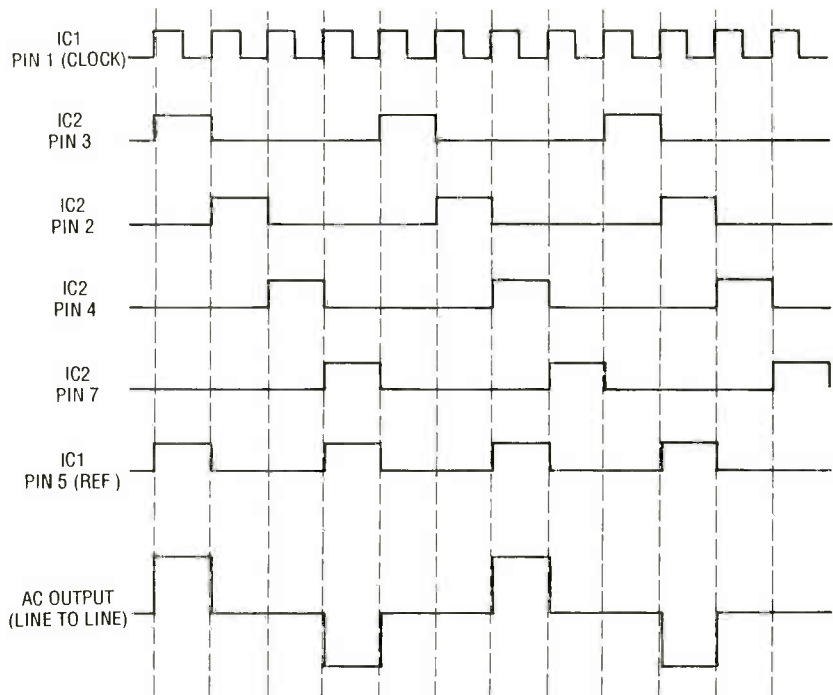

FIG. 3—THE TIMING RELATIONSHIPS in the inverter. When IC2 pin 3 goes high, the output of buffer IC1-c (pin 8) is high. That reverse biases D1 and allows the error amp signal to reach Q1, Q2, and Q3. At the same time, IC2 pin 4 is low, which causes the output of buffer IC1-d to be low. That grounds the gates of Q4, Q5, and Q6 thereby turning them off.

the FET's should be insulated.

Parts placement isn't critical except for the 100-ohm gate resistors. They prevent VHF oscillations and should be placed within half an inch of the FET's. Just make sure that everything is securely mounted inside the cabinet to prevent shorting. Also, the prototype's metal cabinet has had several half-inch holes drilled in the bottom and rear for ventilation.

Power up

To safely test the inverter, it should really be operated with a

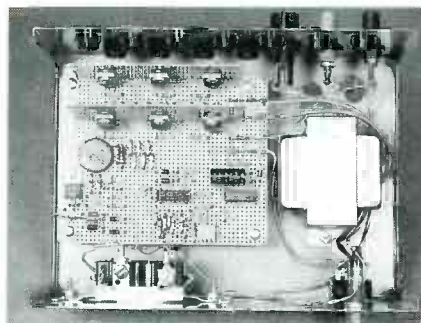

FIG. 4—IN THE PROTOTYPE, the FET's are not insulated from the heatsinks because the heatsinks are isolated from ground and all other circuitry.

1-amp current-limited power supply. If you don't have one, simply connect it to approximately 12-volts DC, and keep a look out for smoke or sudden failures.

Connect an oscilloscope ground to chassis ground and the probe to the junction of D3 and D6; you will see an alternating DC signal. The frequency should be between 70 and 90 Hz. If it isn't you can adjust it by changing the value of R27. Adjust trimmer R17 for 180-volts peak. If you use a DVM or a VOM, connect it across the inverter's AC outlet, and adjust R17 for 120-volts AC.

Now it's time for a full-power test. You will need a 12.6 volt, 10-amp power supply or a car battery. A 120-volt, 40-watt light bulb makes a good load for testing. With a 12.6-volt input, the inverter will deliver 150 volts peak, which will read about 105 volts on a DVM. With a 14.2-volt input, which is what an automobile alternator supplies, the output will be 115-volts AC.

We're sure you'll find many uses for your inverter at home or on the road.

R-E

ELENCO & HITACHI PRODUCTS AT DISCOUNT PRICES

NEW! RSOs (Real-Time & Storage Oscilloscopes) From HITACHI **NEW!**
View, Acquire, Test, Transfer and Document Your Waveform Data
The RSO - its the new solution

Compact Series Scopes

4-Channel, 100MS/s Model	Introductory Price
100MS/s (25MS/s on 4 channels simultaneously), 100MHz, 4kw x 1ch., 2kw x 2ch., 1kw x 4ch. VC-6145	\$ 4,695.00
Compact, Full Feature Models	
40MS/s, 100MHz, 4kw x 1ch., 2kw x 2ch.	VC-6045 \$ 3,049.00
20MS/s, 50MHz, 2kw x 2ch.	VC-6025 \$ 2,295.00
Low Cost/High Value Models	
20MS/s, 50MHz, 2kw x 2ch.	VC-6024 \$ 2,049.00
20MS/s, 20MHz, 2kw x 2ch.	VC-6023 \$ 1,749.00

RSOs from Hitachi feature such functions as roll mode, averaging, save memory, smoothing, interpolation, pretriggering, cursor measurements, plotter interface, and RS-232C interface. With the comfort of analog and the power of digital.



Delayed Sweep
Lightweight (13lbs)
2mV Sens
3 Yr Warranty

Model V-1065
Shown

This series provides many new functions such as CRT Readout, Cursor measurements (V-1085/1065/665), Frequency Ctr (V-1085), Sweeptime Autoranging and Trigger Lock using a 6-inch CRT. You don't feel the compactness in terms of performance and operation.

V-660	60MHz Dual Trace	\$1,195
V-665	60MHz Dual Trace w/Cursor	\$1,345
V-1060	100MHz Dual Trace	\$1,425
V-1065	100MHz Dual Trace w/Cursor	\$1,695
V-1085	100MHz Quad Trace w/Cursor	\$2,045
V-1100A	100MHz Quad Trace w/Cursor	\$2,295
V-1150	150MHz Quad Trace w/Cursor	\$2,775



V-212
\$435
DC to 20MHz
Dual Channel
Hitachi Portable Scopes
DC to 50MHz, 2-Channel, DC offset
function, Alternate magnifier function
V-525 CRT Readout, Cursor Meas. \$1,025
V-523 Delayed Sweep \$995
V-522 Basic Model \$895

V-422 40MHz Dual Trace \$795

20MHz Elenco Oscilloscope

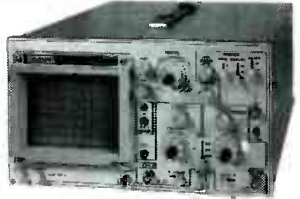

\$375
MO-1251
• Dual Trace
• Component Tester
• 6" CRT
• X-Y Operation
• TV Sync
• 2 p-1 Probes

FREE DMM
with purchase of
ANY SCOPE

SCOPE PROBES
P-1 65MHz, 1x, 10x \$19.95
P-2 100MHz, 1x, 10x \$23.95

Elenco 35MHz Dual Trace

Good to 50MHz **\$495**



MO-1252
• High Luminance 6" CRT
• 1mV Sensitivity
• 6KV Acceleration Voltage
• 10ns Rise Time
• X-Y Operation • Z Axis
• Delayed Triggering Sweep
• Includes 2 P-1 Probes

All scopes include probes, schematics, operators manual, and 3 year (2 yrs for Elenco scopes) world wide warranty on parts & labor. Many accessories available for all Hitachi scopes. Call or write for complete specifications on these and many other fine oscilloscopes.

WE NOW CARRY COMPLETE LINE OF FLUKE MULTIMETERS Models

21F	83
23F	85
25F	87
27F	8050A
73	8060A
75	8062A
77F	+ More

CALL FOR SPECIAL PRICING

True RMS 4 1/2 Digit Multimeter M-7000
\$135
.05% DC Accuracy
.1% Resistance with Freq. Counter and deluxe case

10 Function Multimeter CM-365
\$65
AC + DC Voltage & Amps
Resistance to 2000Ω
Diode, Logic, & Trans test
Capacitance to 200uF

Digital Capacitance Meter CM-1550
\$58.95
9 Ranges
.1pf-20,000ufd
.5% basic accy
Zero control with case

Digital LCR Meter LC-1801
\$125
Measures:
Coils 1uH-200H
Caps .1pf-200uf
Res .01-20M

Function Generator Blox #9600
\$28.95
Provides sine, triangle, square wave from 1Hz to 1MHz AM or FM capability

Triple Power Supply XP-620
Assembled \$65
Kit \$45
2 to 15V at 1A,
-2 to -15V at 1A
(or 4 to 30V at 1A and 5V at 3A)

Contains all the desired features for doing experiments. Features short circuit protection, all supplies.

Wide Band Signal Generators SG-9000
\$129
RF Freq 100K-450MHz
AM Modulation of 1KHz
Variable RF output

SG-9500 w Digital Display and 150MHz built-in Counter \$249

AC Current Meter ST-1010
\$69.95
1000 Amps
Data & Peak hold
8 Functions
Deluxe Case

Decade Blox #9610 or #9620
\$18.95
#9610 Resistor Blox
47 ohm to 1M & 100K pot
#9620 Capacitor Blox
47pf to 10MFD

Quad Power Supply XP-580
\$59.95
2-20V at 2A
12V at 1A
5V at 3A
-5V at .5A

Fully regulated and short circuit protected
XP-575 without meters \$39.95

LEARN TO BUILD AND PROGRAM COMPUTERS WITH THIS KIT!
INCLUDES: All Parts, Assembly and Lesson Manual

Model MM-8000
\$129.00

Starting from scratch you build a complete system. Our Micro-Master trainer teaches you to write into RAMs, ROMs and run a 8085 microprocessor, which uses similar machine language as IBM PC. You will write the initial instructions to tell the 8085 processor to get started and store these instructions in permanent memory in a 2816 EPROM. Teaches you all about input and output ports, computer timers. Build your own keyboard and learn how to scan keyboard and display. No previous computer knowledge required. Simple easy to understand instruction teaches you to write in machine language.

ROBOTICS KIT FOR ABOVE (MM-8010) \$71.95

Digital Triple Power Supply XP-765
\$249
0-20V at 1A
0-20V at 1A
5V at 5A

Fully regulated, Short circuit protected with 2 limit control, 3 separate supplies
XP-660 with Analog Meters \$175

GF-8016 Function Generator with Freq. Counter
\$249
Sine, Square, Triangle Pulse, Ramp, .2 to 2MHz
Freq Counter .1 - 10MHz

GF-8015 without Freq. Meter \$179

WE WILL NOT BE UNDERSOLD!
UPS Shipping: 48 States 5%
(\$10 Max) IL Res., 7% Tax

C & S SALES INC.
1245 Rosewood, Deerfield, IL 60015
(800) 292-7711 (708) 541-0710

15 Day Money Back Guarantee
2 Year Warranty Prices subject to change
WRITE FOR FREE CATALOG

CIRCLE 109 ON FREE INFORMATION CARD

APRIL 1991

SUPER LONG PLAY TAPE RECORDERS

12 Hour Model — USES 120 TAPE \$119.00*



Modified Panasonic Slimline, high quality AC-DC provide 6 continuous hours of quality recording & playback on each side of cassette for 12 hours total. Includes • Voice level control • Digital counter, etc. TDK - 120 Cassette Furnished.

PHONE RECORDING ADAPTER

Records calls automatically. All Solid state connects to your telephone jack and tape recorder. Starts recording when phone is lifted. Stops when you hang up. \$28.50*



VOX VOICE ACTIVATED CONTROL SWITCH

Solid state. Self contained. Adjustable sensitivity. Voices or other sounds automatically activate and control recorder. Uses either recorder or remote mike. \$28.50*



*Add for ship & hdlg. Phone Adapter & Vox \$1.50 ea. Records \$4.00 ea. Cal. Res. add tax. Mail order. VISA, M/C, COD's OK. Money Back Guarantee. Qty. disc. avail.. Dealer Inquiries invited. Free data. © AMC SALES INC. Dept. A 9335 Lybec St. Box 928. Downey, CA 90241. Phone (213) 869-8519 FAX (213) 923-1478

CIRCLE 108 ON FREE INFORMATION CARD

FCC NO-CODE AMATEUR RADIO LICENSE

The FCC recently passed Docket 90-55 which for the first time allows a new codeless entry ham radio license of technician grade. Privileges 30 MHz and above — All modes! (See R.E. article in April 1991 issue).

Get all the no-code license details, study & testing information plus a one-year subscription to one of ham radio's longest running specialty mode publications that will teach you all about the new modes you will be able to operate!

FSTV SSTV FAX RTTY PACKET AMTOR OSCAR FM REPEATERS MICROWAVE AND LOTS MORE!

SEND \$25 CHECK OR MONEY ORDER



OUR 24TH YEAR SINCE 1967!

The SPEC-COM Journal P.O. Box 1002, Dubuque, IA 52004 (319) 557-8791

MC/VISA (5% added)

VCP200

cont. from page 56

mentation, try using a 10K potentiometer in place of R8, and a 1K resistor in place of R9. 10K the tap of the potentiometer as the output to the comparator. That way, a steady amplifier offset is maintained while allowing considerable adjustment of the comparator threshold.

Interfacing

The outputs of the VCP200 can only source and sink small amounts of current and must be protected from reverse EMF and noise. Fortunately, a variety of interface circuits can be devised. One simple power driver is shown in Fig. 7. The desired output from VCP200 is connected to the SELECT input, where it drives the base of the PNP transistor. The transistor supplies power to the relay, which can have any type and arrangement of contacts necessary.

In some cases, it may be handy to be able to toggle an output device on and off. The circuit in Fig. 8 permits just that. Upon power-up, the output of the flip flop will be low. When an active low from the VCP200 is applied to the SELECT input, the output will latch high. The next active low will cause the flip flop output to drop low again.

A more sophisticated output circuit is shown in Fig. 9. On power-up, both outputs will be high. When the GO output of the VCP200 is selected, that output will be latched low. If the VCP200's REVERSE output is selected, the GO OUT output will be toggled high and REVERSE OUT will latch low. If a STOP signal from the VCP200 is received, both flip flop outputs will be toggled high.

The circuit in Fig. 10 allows a complete reset of the voice recognition circuit and any outlying

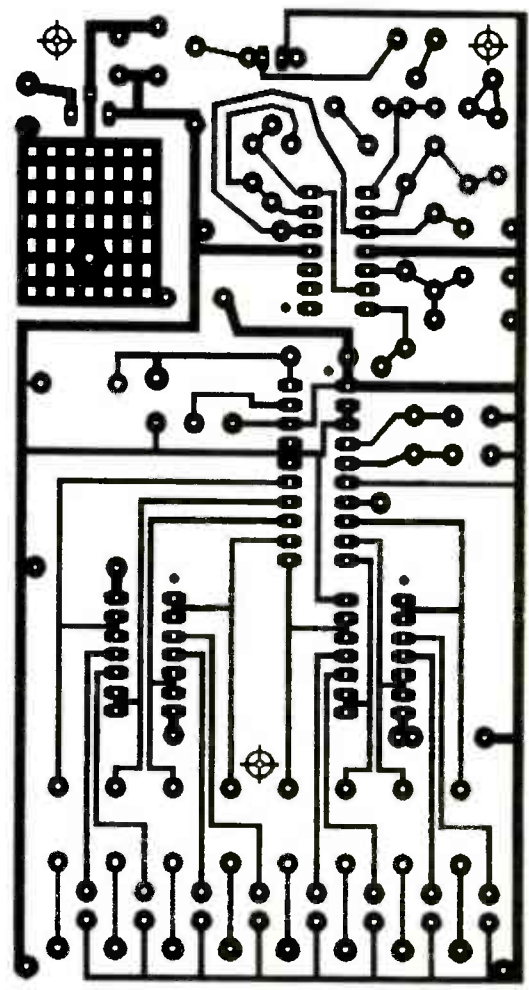

THE "WORKING" VERSION of the project is made on this board, which omits the LED's and their drivers.

circuitry with a voice command. When the RESET output of the VCP200 is selected, the monostable multivibrator, composed of the first two gates and the RC junction, produces a pulse that is routed back to the VCP200's reset pin, pin 20. That forces a reset of the voice-recognition circuit. The pulse can be tapped by another CMOS gate (either inverting, as shown, or noninverting, or both), and used to reset outlying circuitry. Given the imperfect nature of voice control, this circuit is recommended.

You now have some basic building blocks on which you can base your voice-control experiments. Keep in mind that, even though the command words understood by the VCP-200 are best suited for controlling a robot, they can be used to control virtually anything.

R-E

HARDWARE HACKER

New hackable project ideas, infrared people detectors, "in-package" battery testers, another contest, and machine-shop resources.

DON LANCASTER

I have recently gone over dozens of my successful hardware hacking projects and hundreds of my failures over several decades, trying to fathom what worked and what did not. I'm convinced that one of the key underlying secrets is watching for and then profiting from *paradigm shifts*.

A *paradigm* is just the way people perceive things to be. Any *paradigm shift* occurs whenever someone upsets the apple cart—which would happen whenever any vastly new or different way of doing things becomes obvious or when something becomes much cheaper or more widely available.

In general, hardware hacking does not do well in the "business as usual" times. It is only when some sudden and dramatic change or other fundamental shift in values takes place that new opportunities emerge.

Some ancient personal examples of paradigm shifts: The low-cost silicon controlled rectifiers that blew the thyatron out of the saddle and opened up psychedelic lighting; triacs that made light dimmers and power-tool speed controls possible; and RTL digital integrated circuits that revolutionized counting and digital logic.

Other examples include cheap nickel-a-bit shift registers and character generators that permitted my *TV Typewriter (Radio-Electronics, September 1973)* to be the opening round fired in the personal-computer revolution.

Let's not leave out price reductions in CMOS chips; the 6502; the KIM-1 microcomputer; de-mathifying those pseudorandom sequence generators; the Apple IIe; the monumental new stupidities now hopelessly crippling all of traditional publishing; CD ROM; and that insanely great PostScript language.

Your key hacker opportunity: The people who are doing the shifting of the paradigm usually do not have the

slightest idea what they are doing, since they will be always rearwardly focusing on the way things were.

When a paradigm shifts, all sorts of new hardware hacking opportunities immediately open up. Especially if you are able to view things from a different perspective—or if you can reduce the cost of something by 50:1, changing the market to something totally foreign (and totally misunderstood) by the way things were.

If there has not been any recent paradigm shift, the chances are it will be tricky to come up with a useful product. For instance, there has not been one iota of improvement in any of those Peltier thermoelectric cooling modules in the past two decades, owing to the inherently low efficiency of those devices. Any hacking work done the "old way" here is probably a total waste of time.

Similarly, if useful computer touch screens would ever have done anything, they should have taken off years ago. The bottom line is that people do not like to touch computer screens, and trying to convince them otherwise is probably fruitless. The same goes for *Dvorak* or other "improved" keyboards.

The whole point of this Hardware Hacker series is to try and identify paradigm shifts that you can work with and profit from. We have seen many recent examples. They include anything and everything involving PostScript, magnetic refrigeration, wavelet theory, desktop finishing, visible laser diodes, direct toner printed

circuits, and book-on-demand publishing, to name just a few.

For some others, see my *Eminently Hackable Emerging Technologies* story found in that July-August 1990 *Midnight Engineering*. And down-loadable as *GENIE PSRT file #116 EMERGOP.TXT*.

The opposite side of the paradigm shift is the *sucker bet*. That is any thoroughly plowed ground that, for one reason or another, just did not and will not ever hack it. Ratholes into which countless corporate dollars have been foolishly dumped with no visible results, or results having the exact opposite of the intended effect. Obvious sucker bets include the UNIX language, the *NeXT* computer, *TrueType*, or most anything involving *Teletext*.

Infrared people detectors

Street prices on the infrared people detectors are dropping very fast, so now is a good time to review how those electronic devices work. Several important uses now include burglar alarms and occupancy sensors.

Any object not at a temperature of absolute zero will radiate heat. At lower temperatures, a *black body radiation* pattern will be produced.

A human will normally radiate at 98 degrees Fahrenheit, compared to other objects in the room which will typically radiate at a 70-degree range. A human body is a very weak radiator which becomes even more so when compared against the ambient. Figure 1 is a typical curve of human body radiation in a normal room. As you can see, the radiated energy is centered on the eight-micrometer range in the far infrared.

One sensor which is capable of detecting the radiation from a person is known as a *pyroelectric infrared detector*. They are available at a very low cost from the *Amperex* division of *Phillips*, among others. As we'll see shortly, Amperex has lots of good ap notes and data sheets available.

NEED HELP?

Phone or write your **Hardware Hacker** questions directly to:
Don Lancaster
Synergetics
Box 809
Thatcher, AZ 85552
(602) 428-4073

A pyroelectric infrared detector consists of one or two detectors that, in turn, input to a field effect transistor (FET) source follower. The basic detector is a capacitor, across which several hundred microvolts DC will be generated in the presence of a warm and non-moving human body. The detectors are often used in side-by-side differential pairs that are imaged slightly differently. They then tend to cancel out stationary sources.

One very big gotcha here: The sensors are basically a capacitor so they cannot indefinitely produce a DC output. Even the tiny bias current of a FET's gate is enough to flatten any long-term DC level. Thus, the pyroelectric infrared detector is able to respond only to *changing* levels of infrared energy. Stationary sources are ignored.

So, the trick is to make the infrared signals appear to be rapidly changing. One obvious way is to have the person run through the beam. That can produce a usable transient. But something better is clearly needed.

The traditional method was to chop the beam by putting a bladed fan in

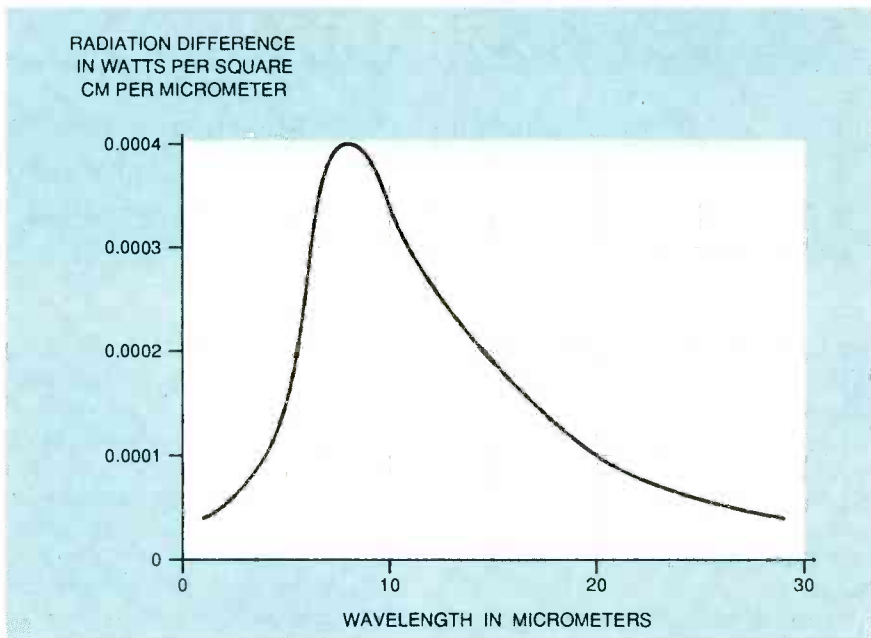

FIG. 1—THE FAR INFRARED SIGNATURE of a 98-degree F person in a 70-degree room environment. Note that these are extremely weak power levels.

front of it. That would input an infrared square wave that represents the difference between the body and fan blade temperatures. By knowing how fast those blades whipped past you, you could also do a *synchronous demodulation* that would increase your detection sensitivity. But moving fan blades and synchronous detectors are expensive.

Somehow you have to gather the infrared energy from your area and concentrate it on the detector surface. While mirrors are one solution, a plastic *Fresnel lens* is better.

Now for the tricky part. Instead of making the lens operate uniformly over the surveyed area, it is purposely striped so that there are "strong" and "weak" sensing areas. A typical lens pattern is shown in Fig. 2. As the person walks through the beam or otherwise moves, they travel between the strong and weak lens areas, creating more of a varying signal than they would otherwise.

Figure 3 shows you a schematic of a simple people detector using a dual-element pyroelectric detector and a quad op-amp. The Fresnel lens has strong and weak areas that alter the strength of the infrared signature of a moving person. That is sensed by the detector and routed to a $\times 600$ AC amplifier. The combined frequency response of the detector and the amplifier is in the 0.3- to 5-Hertz range. That is usually optimum for most people movements.

The output of your amplifier is routed to a *window detector* or dual comparator. The detector will output a signal on any sudden change in the infrared signature. Usually, the output of the window detector is routed to a counter of some sort to minimize false alarms.

In security applications, an alarm output is created. For the occupancy detectors, the lights are quickly turned on, and then left on for a selected number of minutes. A fifteen-minute delay is often optimum for people who are usually sitting at a desk or bench. Each time they move, the on time gets extended.

One commercial source of ready-to-go occupancy sensors is *Leviton*. They fit in an ordinary power outlet. Occupancy sensors can dramatically reduce the power bills in most larger commercial buildings.

Another alternative to pyroelectric detectors is the *Kynar Piezo Film* from *Atochem* (formerly *Pennwalt*). While less sensitive to infrared and much more tuned in to motion or vibration, this approach can let you integrate your lens and sensor into one single thin assembly.

While the electronics involved in people detection are both simple and straightforward, your mirror or lens design is not. Thus, you are better off using some already developed and debugged commercial lens/detector combination than trying to work one up from scratch.

**NEW FROM
DON LANCASTER**

HARDWARE HACKER STUFF

Hardware Hacker Reprints II or III	24.50
Incredible Secret Money Machine	13.50
CMOS Cookbook	24.50
TTL Cookbook	19.50
Active Filter Cookbook	19.50
Micro Cookbook vol I or II	19.50
Lancaster Classics Library	109.50
Enhancing your Apple I or II	17.50
AppleWriter Cookbook	19.50
Apple Assembly Cookbook	21.50
Absolute Reset IIe & IIc	19.50
Enhance I or II Companion Disk	19.50
AppleWriter CB or Assy CB Disk	24.50

POSTSCRIPT STUFF

Ask The Guru Reprints I, II or III	24.50
LaserWriter Secrets (IIe/Mac/PC)	29.50
PostScript Show & Tell	39.50
Intro to PostScript VHS Video	39.50
PostScript Beginner Stuff	39.50
PostScript Cookbook (Adobe)	16.50
PostScript Ref. Manual (Adobe)	22.50
PostScript Program Design (Adobe)	22.50
Type I Font Format (Adobe)	15.50
LaserWriter Reference (Apple)	19.50
Real World Postscript (Roth)	22.50
PostScript Visual Approach (Smith)	22.50
Thinking in PostScript (Reid)	22.50
The Whole Works (all PostScript)	299.50

FREE VOICE HELPLINE VISA/MC

SYNERGETICS
Box 809-RE
Thatcher, AZ 85552
(602) 428-4073

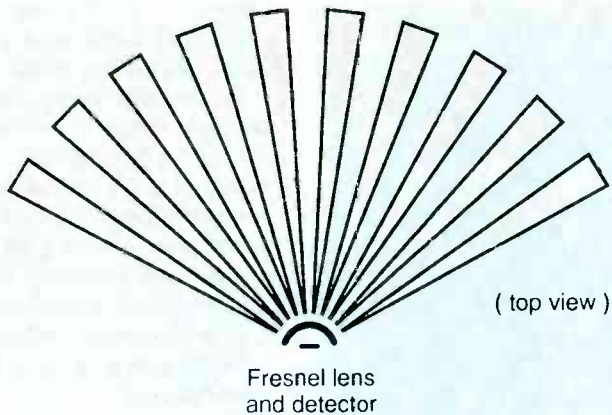

FIG. 2—SINCE PYROELECTRIC INFRARED SENSORS are capacitors, they cannot hold a DC or stationary level. To emphasize changes in motion, special Fresnel lenses are often used that have “hot” and “cold” areas as shown here.

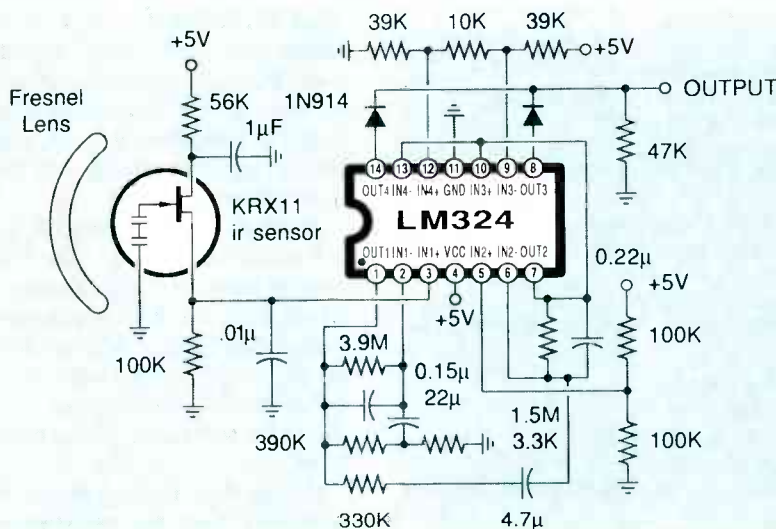

FIG. 3—A “PEOPLE DETECTOR” intended for use as an office lighting control. The output goes high on any motion detection that would increase or decrease the input far infrared signature.

- Pyroelectric infrared detectors for movement sensing.
Technical publication #134, 1984
- Remote level sensing using pyroelectric infrared detectors.
Technical publication #135, 1980
- Low cost remote sensing radiometer using the RPY89 infrared detector.
Technical publication #138, 1980
- Low cost automatic light switching using passive infrared sensors.
Technical publication #147 February 1985
- Ceramic pyroelectric infrared sensors and their applications.
Technical publication #163
- Passive infrared (PIR) intruder alarms.
Technical publication #213 April 1986
- Movement sensing using a multi-element fresnel lens.
Amperex ap note, November 1988.
- KRX10 dual element pyroelectric infrared sensor.
Data sheet, September 1988.
- KRX11 dual element pyroelectric infrared sensor.
Data sheet, September 1988
- RPW100 dual element pyroelectric infrared sensor.
Data sheet, September 1988
- Fresnel lens data sheet and explanatory notes.
Phillips data sheet, April 1986

FIG. 4—AMPEREX AP NOTES and data sheets on pyroelectric infrared detectors.

Figure 4 lists some of the more readable *Amperex* ap-notes and data sheets on people detecting. It is a very good starting point for picking up all the infrared sensing basics.

Battery testers

As all of you long-time Hardware Hackers know, I am very much a fan of *elegant simplicity*, or any way to do very much with very little. Those *Duracell* folks have finally reduced battery testing to an elegantly simplistic minimum. Just in case you haven't noticed, there's now a free battery tester built into their battery packaging. An incredibly sophisticated one, and obviously cheap.

Flashlight cells do not often fail suddenly. Instead, because of cell polarization and other effects, their internal resistance slowly increases. That, in turn, drops the cell's voltage under load, eventually to the point where they can no longer be used.

To test a flashlight cell, just place a power resistor across it that represents a fairly heavy load for that size cell. Wait several seconds. Then measure the battery's open-circuit voltage.

In the *Duracell* package, there is a pair of printed contacts with a printed power resistor between them. Around three ohms for the AA-size alkaline cell. The resistor gets noticeably hot when you connect your cell to it.

Now for that elegantly simple part. As Fig. 5 shows us, the printed resistor is not uniform. Instead it forms a wedge shape. The narrow portion of the wedge at the bottom will have a higher resistance *per unit length* and thus will get *hotter* than the upper, wider part. Thus, this particular resistor will set up a temperature gradient that is hottest at the bottom and coolest at the very top.

How hot? Well, that all depends on how much current your cell puts out under load. Power equals the current squared times the total resistance.

A thin liquid-crystal coating gets placed on the reverse side of the resistor. It's the same stuff used in clinical and desk thermometers. At a certain *transition temperature*, the liquid crystal will turn a bright green. Below that temperature it will remain black, and above it a dark gray.

The more the available current under load, the higher the green spot on the display. So, a “good” cell will

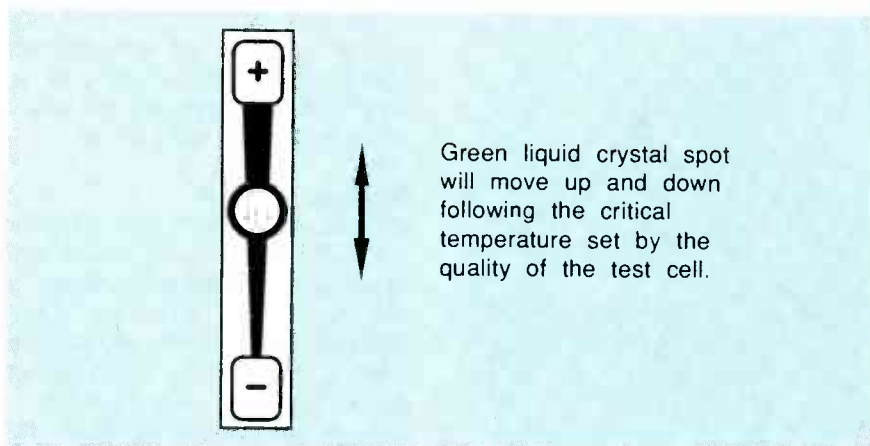

FIG. 5—THE LOAD RESISTOR in the Duracell battery tester is wedge shaped so that it gets hotter per unit length at the bottom than at the top. A liquid-crystal coating changes color at a critical temperature, moving a green indicating spot up with a strong cell and down with a weak one.

NAMES AND NUMBERS

Atotech (formerly Pennwalt)

Box 799
Valley Forge, PA 19482
(215) 666-3500
CIRCLE 301 ON FREE INFORMATION CARD

Burr-Brown

6730 South Tucson Blvd
Tucson, AZ 85706
(602) 746-1111
CIRCLE 302 ON FREE INFORMATION CARD

Circuits Assembly

500 Howard Street
San Francisco, CA 94105
(415) 397-1881
CIRCLE 303 ON FREE INFORMATION CARD

Duracell

Berkshire Industrial Park
Bethel, CT 06801
CIRCLE 304 ON FREE INFORMATION CARD

Exel

2150 Commerce Drive
San Jose, CA 95131
(408) 432-0500
CIRCLE 305 ON FREE INFORMATION CARD

GEnie

401 North Washington Street
Rockville, MD 20850
(800) 638-9636
CIRCLE 306 ON FREE INFORMATION CARD

Leviton

59-25 Little Neck Pkwy
Little Neck, NY 11362
(800) 824-3005
CIRCLE 307 ON FREE INFORMATION CARD

Midnight Engineering

111 East Drake Road, Ste 7041
Fort Collins, CO 80525
(303) 491-9092
CIRCLE 308 ON FREE INFORMATION CARD

Motion Control

800 Roosevelt Rd, Ste E-408
Glen Ellyn, IL 60137
(708) 469-3373
CIRCLE 309 ON FREE INFORMATION CARD

Newark Electronics

228 East Lake Street
Addison, IL 60101
(708) 941-7200
CIRCLE 310 ON FREE INFORMATION CARD

NSRA News

PO Box 3724
Ann Arbor, MI 48106
(313) 994-6088
CIRCLE 311 ON FREE INFORMATION CARD

Phillips/Amperex

100 Providence Pike
Slatersville, RI 02876
(401) 762-3800
CIRCLE 312 ON FREE INFORMATION CARD

Phillips/Signetics

45 George Washington Hwy
Smithfield, RI 02917
(401) 232-0500
CIRCLE 313 ON FREE INFORMATION CARD

Professional Glass Consultants

1409 Kuehner Drive, Ste 494
Simi Valley, CA 93063
(805) 527-5375
CIRCLE 314 ON FREE INFORMATION CARD

Synergetics

Box 809
Thatcher, AZ 85552
(602) 428-4073
CIRCLE 315 ON FREE INFORMATION CARD

Teltone

10801 120th Avenue NE
Kirkland, WA 98033
(800) 426-3926
CIRCLE 316 ON FREE INFORMATION CARD

have a "high" green spot, and a "bad" cell might have a "low" green spot, or perhaps none at all.

The results surely change with the ambient temperature and the size of the cell being tested, but they assume you are testing your cells at room temperature, and that the cell being tested is the type and size provided in the package. Basically what you have here is a three-cent 0 to 500 DC milliammeter. What other uses can you come up with for this great new concept?

Elegant simplicity contest

What else is elegantly simple? For sure the P-38 can opener, which I rank as far and away the most outstanding invention of the twentieth century, bar none. Such frivolities as automobiles, televisions, computers, aircraft, and even Hostess Twinkies should pale by comparison. Especially when you factor in bang-for-the-buck, reliability, first costs, complexity, and the end-user performance.

For this month's contest, just tell me about something in the P-38 can opener class that really needs further developing. We'll have a dozen or so *Incredible Secret Money Machine* book prizes, along with an all-expense-paid (FOB Thatcher, AZ) *tinaja quest* for two going to the best entry of all.

To get you thinking about elegant simplicity, here are some ideas: We need a sleeping-bag zipper with a "snowplow" snoot on it that doesn't jam itself on the pulled-in material at 4 am. We need a boot shoelace that works, especially in oddball lengths. Sorely needed are a line of gourmet truth-in-advertising foods, such as cream of mushroom soup with mushrooms, or pork and beans with pork. And Detroit is at long last wiseing up to the fact that putting a plain old pin through the differential dramatically improves the handling in mud or snow.

Finally, it goes without saying that we just gotta have a stainless steel potato chip, since the real ones break on the third of fourth time into the dip. Yes, you could use a P-38, but...

Let's have your thoughts on elegant simplicity, electronic or otherwise. As usual, be certain to send all of your written entries directly to me here at *Synergetics*, rather than sending them to **Radio-Electronics** editorial.

MACHINE SHOP RESOURCES

American Machinist

826 Broadway, 4th Floor
New York, NY 10003
(212) 477-6420

CIRCLE 317 ON FREE INFORMATION CARD

Bordens Surplus Center

10156 West O Street
Lincoln, NE 68501
(800) 228-3407

CIRCLE 318 ON FREE INFORMATION CARD

C&H Sales

PO Box 5356
Pasadena, CA 91117
(800) 325-9465

CIRCLE 319 ON FREE INFORMATION CARD

Design News

44 Cook Street, Suite 210
Denver, CO 80206
(303) 388-4511

CIRCLE 320 ON FREE INFORMATION CARD

Enco

5000 West Bloomingdale Ave
Chicago, IL 60639
(800) 621-4148

CIRCLE 321 ON FREE INFORMATION CARD

Home Shop Machinist

2779 Aero Park Drive
Traverse City, MI 49684
(800) 447-7367

CIRCLE 322 ON FREE INFORMATION CARD

Industrial Equipment News

Five Penn Plaza, 8th Floor
New York, NY 10001
(212) 629-1500

CIRCLE 323 ON FREE INFORMATION CARD

Industrial Products Bulletin

PO Box 650
Morris Plains, NJ 07950
(201) 292-5100

CIRCLE 324 ON FREE INFORMATION CARD

J&L Industrial Supply

31800 Industrial Drive
Livonia, MI 48150
(800) 521-9520

CIRCLE 325 ON FREE INFORMATION CARD

KBC Tools

6300 18-Mile Road
Sterling Heights, MI 48314
(800) 521-1740

CIRCLE 326 ON FREE INFORMATION CARD

Kepro

630 Axminster Drive
Fenton, MO 63026
(314) 343-1630

CIRCLE 327 ON FREE INFORMATION CARD

Lindsay Publications

PO Box 583
Manteno, IL 60950
(815) 468-3668

CIRCLE 328 ON FREE INFORMATION CARD

Machine Design

1100 Superior Avenue
Cleveland, OH 44114
(216) 696-7000

CIRCLE 329 ON FREE INFORMATION CARD

McMaster-Carr

Box 54960
Los Angeles, CA 90054
(213) 692-5911

CIRCLE 330 ON FREE INFORMATION CARD

Metalworking Digest

310 Gibraltar Drive
Morris Plains, NJ 07950
(201) 292-5100

CIRCLE 331 ON FREE INFORMATION CARD

Mettfax

29100 Aurora Road, Suite 200
Solon, OH 44139
(216) 248-1125

CIRCLE 332 ON FREE INFORMATION CARD

Model Railroader

21027 Crossroad Circle
Waukesha, WI 53187
(414) 272-2060

CIRCLE 333 ON FREE INFORMATION CARD

Modeltec

Box 286
Cadillac, MI 49601
(616) 775-6296

CIRCLE 334 ON FREE INFORMATION CARD

New Equipment Digest

1100 Superior Avenue
Cleveland, OH 44114
(216) 696-7000

CIRCLE 335 ON FREE INFORMATION CARD

Roper Whitney

2833 Huffman Blvd
Rockford, IL 61103
(815) 962-3011

CIRCLE 336 ON FREE INFORMATION CARD

Rutland

PO Box 587
LaPuente, CA 91747
(800) 289-4787

CIRCLE 337 ON FREE INFORMATION CARD

Small Parts

PO Box 381966
Miami, FL 33238
(305) 751-0856

CIRCLE 338 ON FREE INFORMATION CARD

Used Equipment Directory

601 Pavonia Avenue
Jersey City, NJ 07306
(800) 526-6052

CIRCLE 339 ON FREE INFORMATION CARD

Wholesale Tool

12155 Stephens
Warren, MI 48090
(800) 521-3420

CIRCLE 340 ON FREE INFORMATION CARD

Machine shop resources

What does a hardware hacker really need in the way of purely mechanical "machine shop" stuff? Obviously, it depends on where you live and what you are up to. But it is super easy to pour scads of time and dollars into overpriced machinery that you never use and that will never pay for itself. Either in income or pleasure returned.

I live in a remote rural area, so I guess I've picked up more than I'd recommend in the way of shop tools. I do have a medium-sized drill press which is still precise enough and fast enough to drill a #67 hole in a printed circuit board. I've added a rotary X-Y table to it for light milling.

There is a smallish *Kepro* printed circuit board shear, and my *Roper-Whitney* hand punch. A decent vise is a necessity for sure. A hand moto-tool. Also a largely unused *Atlas* four-inch lathe and the essential grinder to feed it. And finally a table-mounted router.

The first thing you should do is look around your neighborhood and find out what *nonobvious* mechanical resources are available to you. Is there a retired machinist down your street with a full home shop and nothing to do? A community college with open-ended shop courses? Or some firms with excess capacity who could handle the work?

Locally, there is this trailer hitch works that has a giant shear and brake. They can instantly and cheaply cut ten-gauge steel, usually from free scrap off the floor. Other locals I've gladly used include an air-conditioning shop, a ranch-machinery repair service, a solar products factory, and a heavy-machinery rebuilder/trader.

In our resource sidebar for this month, I've tried to gather together a few important hacker machine-shop resources. By far the most important two of these are *Small Parts*, who stock everything your hardware store never heard of and will custom cut metal and plastic for you in tiny quantities; and *Lindsay Publications*, who have a mind boggling array of lower-priced machine-shop books in stock.

One old-line "stocks everything" distributor is *McMaster Carr*. See if you can't cop one of their humongous 3000-page catalogs. Others include *Enco*, *KBC Tools*, *J & L Industrial Supply*, *Rutland*, and



Your Ticket To SUCCESS

Over 28,000 technicians have gained admittance worldwide as certified professionals. Let your ticket start opening doors for you.

IS CET offers Journeyman certification in Consumer Electronics, Industrial, Medical, Communications, Radar, Computer and Video. For more information, contact the International Society of Certified Electronics Technicians, 2708 West Berry Street, Fort Worth, TX 76109; (817) 921-9101.

Name _____
Address _____
City _____
State _____ Zip _____

Send material about IS CET and becoming certified.

Send one "Study Guide for the Associate Level CET Test." Enclosed is \$10 (inc. postage).

Get A Complete Course In

ELECTRONIC ENGINEERING

8 volumes, over 2000 pages, including all necessary math and physics. 29 examinations to help you gauge your personal progress. A truly great learning experience.

Prepare now to take advantage of the growing demand for people able to work at the engineering level.

Ask for our brochure giving complete details of content. Use your free information card number, or write us directly. **\$59.95 to \$119.95**. Postage Included. Satisfaction guaranteed or money refunded.



**Banner
Technical
Books, Inc.**

1203 Grant Ave.
Rockford, IL 61103

Wholesale Tool. And, of course, *Sears*. Two useful surplus sources include *Bordens* and *C & H Sales*.

My favorite two mechanical trade magazines are *Design News* and *Machine Design*. The zillions of others include *American Machinist*, the *Used Equipment Directory*, and *Metlfax*.

There's also a huge collection of oversize "throwaway" shoppers that include *New Equipment Digest* (great free product samples!), *Industrial Product Bulletin*, *Industrial Equipment News*, and also *Metalworking Digest*.

On the hobby side of the fence, *Model Railroader* obviously belongs on this list. Two others include *Home Shop Machinist* and *Modeltec*.

Once again, we've got a rather long list here, but I have a hollow feeling I've missed something major. For our second contest this month, just tell me about any hacker-useful machine-shop resource that I don't already know about.

New tech literature

There is a great *Telecom Design Solutions* manual from *Teltone* this month on such neat goodies as call-progress detectors and DTMF chips. Included are some great ap notes. And from *Phillips/Signetics*, a new data handbook on *Programmable Logic Devices* for your custom work. From *Newark Electronics*, a new 1300-page *Catalog #111* on everything electronic that they distribute.

New trade journals for this month include *Circuits Assembly* on printed circuit boards and *Motion Control* on robotic power controls. Newsletters include *Robotics Now* and the *NSRA News*, the latter from the *National Service Robot Association*. *Burr Brown* has just introduced an applications and product info BBS at (602) 741-3978.

In our free samples department, *Excel* has borrowed a marketing ploy from the magazine clearing houses—a series of stamps. Pick any three on the return card for free samples of their non-volatile memory products. And *Annulus* has free samples of their 8PDT switches which are great for switching serial ports or any EPROM chips into or out of circuit. For mechanical stuff, the definitive books and videos on glass etching are available through *Professional Glass Consultants*.

Turning to my own products, for the essentials of making your hardware hacking profitable, check out my *Incredible Secret Money Machine* book. I have also just released the *Hardware Hacker III* and *Midnight Engineering* book-on-demand published reprints.

I do have this great new PostScript PSRT roundtable and library up on *GENie*. You'll also find lots of *Hardware Hacker* and all of the *Midnight Engineering* reprints here.

Finally, I do have a new and free mailer for you that includes dozens of insider hardware hacking secret resources. Write or call for info.

Our usual reminder here that most of the items mentioned appear either in the *Names and Numbers* or in the *Machine Shop Resources* sidebars. As always, this is your column and you can get technical help and off-the-wall networking per that *Need Help?* box. The best calling times are weekdays 8-5, *Mountain Standard Time*. Let's hear from you. **R-E**

ASK R-E

continued from page 12

shock if you use a piece of wood to poke around in the guts of a TV set. I found that out the hard way. The shock wasn't too bad but I almost got a concussion when I was thrown across the room and my head hit the wall.

Your typical flyback transformer is shown in Fig. 2. You can try to eliminate the noise by covering the transformer with RTV high-voltage putty. If you can't get your hands on any of that stuff, you can use hot-melt glue as a substitute. I've used both of them. If you're lucky, the chances are that the stuff will coat the transformer well enough to eliminate the noise—or at least cut it down a bit.

If that doesn't work, you can try tightening the bolts or whatever is holding the transformer in the TV set. You can wedge small pieces of thin plastic between the transformer and the chassis or circuit board to keep either of them from acting as a sounding board and, as a result, amplifying the squeal.

Whatever you try, remember to respect the voltages generated in the TV set. High-voltage shocks can be deadly at worst...and shocking at best. **R-E**

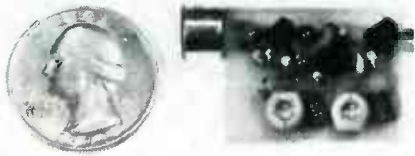

SIMPLY SNAP THE WAT-50 MINIATURE FM TRANSMITTER on top of a 9v battery and hear every sound in an entire house up to 1 mile away! Adjustable from 70-130 MHz. Use with any FM radio. Complete kit **\$29.95 + \$1.50 S + H**. Free shipping on 2 or more! COD add \$4. Call or send VISA, MC, MO. **DECO INDUSTRIES, Box 607, Bedford Hills, NY 10507. (914) 232-3878.**

CIRCLE 127 ON FREE INFORMATION CARD



GENERAL TECHNICS COMPUTER KITS offer a complete line of 8088, 286, and 386 models. Designed to the highest degree of *quality* and *reliability* available today. They're also fun, easy to build, educational, fully **IBM compatible**, very *powerful*, and at wholesale prices. All kits are pre-tested and include a one year warranty, step by step assembly manual, free software, and a 24 hour tech support/order phone line. For free catalog contact: **GENERAL TECHNICS, P.O. BOX 2676, LAKE RONKONKOMA, NY 11779, or call (516) 981-9473, VISA, MasterCharge, American Express, COD**

CIRCLE 184 ON FREE INFORMATION CARD



FREE CATALOG OF TEST INSTRUMENTS & TOOLS is packed with thousands of products for testing, repairing, and assembling electronic equipment. Featured are brand name instruments such as Fluke, Tektronix, Leader, Weller, 3M plus many more. Also included are DMM's, hand tools, power supplies, tool kits, test equipment, static supplies plus many other new products. Orders placed by 4 PM are shipped before we go home! **CONTACT EAST, 335 Willow St., No. Andover, MA 01845, (508) 682-2000, Fax: (508) 688-7829.**

CIRCLE 55 ON FREE INFORMATION CARD

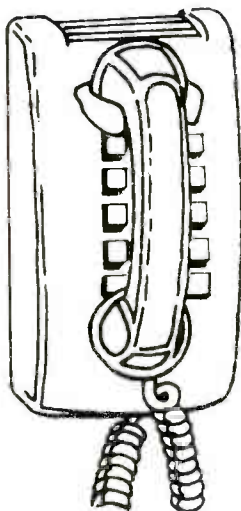

CALL NOW AND RESERVE YOUR SPACE

- 6 x rate \$940.00 per each insertion.
- Fast reader service cycle.
- Short lead time for the placement of ads.
- We typeset and layout the ad at no additional charge.

Call **516-293-3000** to reserve space. Ask for Arline Fishman. Limited number of pages available. Mail materials to: **mini-ADS, RADIO-ELECTRONICS, 500-B Bi-County Blvd., Farmingdale, NY 11735.**

FAX: 516-293-3315



GET YOUR RECHARGE CATALOG FREE...EARN BIG \$\$ IN YOUR SPARE TIME—All supplies and Do-It-Yourself kits with complete instructions available. Supplies cost from **\$9.95** in qty and you can sell recharged toner cartridges for **\$40.00** to **\$55.00** each. Printers include HP LaserJet and Series II, Apple LaserWriter, QMS, etc. Canon PC-25 Copier also. **CHENESKO PRODUCTS, 62 N Coleman Rd., Centereach, NY 11720, 516-736-7977, 800-221-3516, Fax: 516-732-4650**

CIRCLE 181 ON FREE INFORMATION CARD



NEW XST500 SUPER-MINIATURE FM transmitter uses Surface Mount Technology (SMT)! Own the smallest high performance FM transmitter available. Transmits whispers to any FM receiver up to a mile away. Uses 9V battery. Complete, easy to assemble kit, with SMT components already assembled to circuit board. **\$39.95** Cash, VISA, MC. COD add \$5. **XANDI ELECTRONICS, 201 E. Southern Ave., Suite 114, Tempe, AZ 85282. 1-602-829-8152, (1-800-336-7389 orders only).**

CIRCLE 178 ON FREE INFORMATION CARD



THE MODEL WTT-201S ONLY THE SIZE OF A DIME, yet transmits both sides of a telephone conversation to any FM radio with crystal clarity. Telephone line powered - never needs a battery! Up to ¼ mile range. Adjustable from 70-130 MHz. Complete kit **\$29.95 + \$1.50 S + H**. Free Shipping on 2 or more! COD add \$4. Call or send VISA, MC, MO. **DECO INDUSTRIES, Box 607, Bedford Hills, NY 10507. (914) 232-3878.**

CIRCLE 127 ON FREE INFORMATION CARD

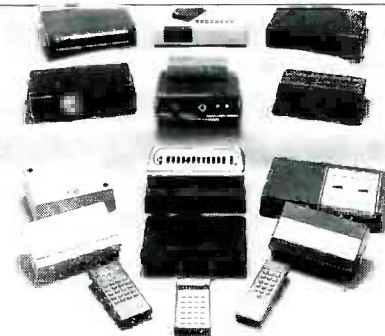

CABLE TV CONVERTERS AND DE-SCRAMBLERS SB-3 **\$79.00** TRI-BI **\$95.00** MLD-**\$79.00** M35B **\$69.00** DRZ-DIC **\$149.00**. Special combos available. We ship COD. Quantity discounts. Call for pricing on other products. Dealers wanted. **FREE CATALOG**. We stand behind our products where others fail. One year warranty. **ACE PRODUCTS, P.O. Box 582, Saco, ME 04072 1 (800) 234-0726.**

CIRCLE 75 ON FREE INFORMATION CARD

DRAWING BOARD

Even though some test equipment is very simple, it can still be quite useful.

ROBERT GROSSBLATT

Test equipment has changed over the last ten years or so. As the general nature of electronics gets more complex, so does the type and amount of equipment you need on the bench. It used to be that all you really needed was a power supply and a bunch of luck, but that's not true any more.

If you have a healthy budget, you can buy almost anything you need in the way of equipment but, if you're like most of us, you have to blow most of your hard earned money on stuff like rent, food, and other foolishness. In that case, the only alternative for your home workbench is to build the equipment you need as the need for it arises.

That isn't quite as dreary as it sounds since the design and construction of basic test gear can be a good learning experience. As with any other design project, you should have a clear idea of what you want before you sit down to produce it. That's not as silly as it sounds because, as I can see from the mail I get, a lot of people screw up simply because they get started on doing things without really knowing what they want to do in the first place.

The right way to go about designing something is to first sit down and think things out in a logical order. First decide what it is that you need to do. Then figure out the easiest, quickest, and cheapest way to do it. Don't go crazy adding features that are not related to the main function, or ones that will never get used. That will only add unnecessary expense and effort to the project. And, quite often, excessive features can actually get in the way of the intended application. It is a good idea, though, to add features that will speed up or lend a hand to whatever your original goal was.

Interestingly enough, one of the most useful things you can have on a bench is also something that I've never seen produced by any of the large commercial manufacturers. What I'm

talking about here is a good source of bounceless pulses. There are lots of pulse generators on the market, but all I frequently need is a completely debounced mechanical switch—usually several of them.

There's nothing complex about building something like that but, for some reason, you have to do it yourself. I've never seen anything like it available commercially.

Debouncing switches is a simple procedure and there are lots of ways to get it done. All we need is a circuit that produces a clean output pulse whenever it's triggered. The electronics involved are minimal since you can use anything from a handful of ordinary passive components to a 555-based circuit. Since I like to keep things as simple as possible while still providing as much flexibility as I can in the final product, I used a half monostable multivibrator as the foundation of the circuit (see Fig. 1).

The nice thing about this approach to the problem is that, since the circuit only uses one inverter, I can get six switches out of a single chip. There's no reason why you can't use noninverting buffers instead of the inverters. All that will be different is that both the input and output pulses will

be in the same direction. I used an inverter because I had some spare ones lying around and you'll probably make your choice for exactly the same reason.

Since I frequently need both positive- and negative-going pulses, I used two IC's to produce twelve bounceless switches. Six of them are positive-going and six of them are negative-going. The whole assembly is in a small plastic box with thirteen sets of terminals on it—twelve for the switch outputs and one for power. The resistors on the outputs of the gates are there to provide a bit of protection for the IC. They limit the current and also help isolate the circuit I'm working on from the switch box. I could have used diodes (which would have been a lot better), but I didn't have any around at the time and, since I never had a problem, I never changed anything.

It's always good practice to isolate the circuit you're working on from the test equipment you're using. You never know what's going to happen and, in case you've forgotten, the reason you're using test gear is because your design is still being tested.

While we're on the subject of trivial things, you should also build some

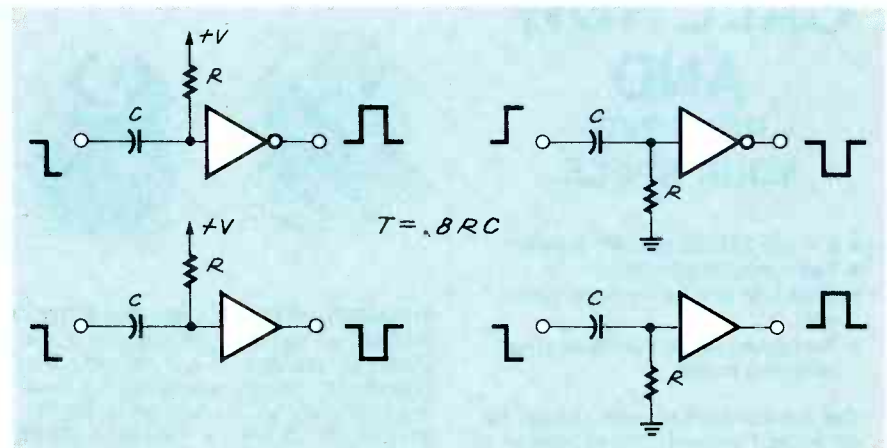

FIG. 1—A HALF MONOSTABLE MULTIVIBRATOR is the foundation of the switch-debouncer circuit. Six switches can be made from a single chip, but since positive- and negative-going pulses may be needed, two IC's are used to produce six positive-going and six negative-going bounceless switches.

R-E Engineering Admart

Rates: Ads are 2 1/4" x 2 7/8". One insertion \$995 each. Six insertions \$950 each. Twelve insertions \$925 each. Closing date same as regular rate card. Send order with remittance to Engineering Admart, Radio-Electronics Magazine, 500-B Bi-County Blvd., Farmingdale, NY 11735. Direct telephone inquiries to Arline Fishman, area code-1-516-293-3000. FAX 1-516-293-3115. Only 100% Engineering ads are accepted for this Admart.

Surface Mount Chip Component Prototyping Kits—

Only \$49.95



CC-1 Capacitor Kit contains 365 pieces, 5 ea. of every 10% value from 1pf to .33µf. CR-1 Resistor Kit contains 1540 pieces, 10 ea. of every 5% value from 10Ω to 10 megΩ. Sizes are 0805 and 1206. Each kit is ONLY \$49.95 and available for Immediate One Day Delivery!

Order by toll-free phone, FAX, or mail. We accept VISA, MC, AMEX, COD, or Pre-paid orders. Company P.O.'s accepted with approved credit. Call for free detailed brochure.



COMMUNICATIONS SPECIALISTS, INC.
426 West Taft Ave. • Orange, CA 92665-4296
Local (714) 998-3021 • FAX (714) 974-3420

Entire USA 1-800-854-0547

CIRCLE 190 ON FREE INFORMATION CARD

FCC LICENSE PREPARATION

The FCC has revised and updated the commercial license exam. The NEW EXAM covers updated marine and aviation rules and regulations, transistor and digital circuitry. THE GENERAL RADIOTELEPHONE OPERATOR LICENSE - STUDY GUIDE contains vital information. VIDEO SEMINAR KITS ARE NOW AVAILABLE.

WPT PUBLICATIONS
979 Young Street, Suite E
Woodburn, Oregon 97071
Phone (503) 981-5159 Dept. 50

CIRCLE 177 ON FREE INFORMATION CARD

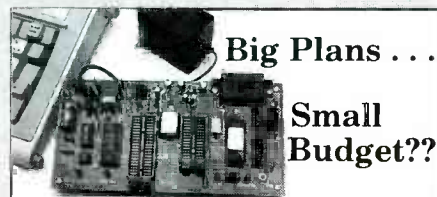

Big Plans . . .

Small Budget??

6805 Microcomputer Development System

TECI's MCPM-1 system allows your IBM PC and Compatibles to be used as a complete development system for the Motorola 6805 family of single chip microcomputers. Many time saving features at an affordable price.

MCPM-1 Programmer for Motorola MC68705P3, P5, U3, U5, R3, R5

MCPM-1 w/driver, assembler, simulator/debugger \$449

MCPM-1 w/driver program only \$349

Also available—Programmer for 68HC05, in-circuit emulators and many software tools to help you. Call for a complete catalog and let us help you select your tools



The Engineers Collaborative, Inc.

Rt. #3 Box 8C Barton, VT 05660 USA

TEL: (802) 525-3458 FAX: (802) 525-3451 Call Toll Free (800) 336-8321

substitution boxes for yourself. Electronics is a fairly exact science, and there are formulas that tell you what combination of passive components to use when you want a particular signal at the output of a circuit. From a practical point of view, formulas are good for the initial stages of a design but, as things evolve, it's really handy to be able to change things quickly and easily.

The key word here is "easily," because from a practical point of view, breadboards tend to be incredibly messy. I always start out with the best of intentions—all power leads are red, ground leads are kept black, etc.—but that always falls apart halfway into the design. Substituting resistors and capacitors is theoretically a simple thing but it can take a long time and a lot of care to swap components on a crowded breadboard. The only way to do it without the risk of accidentally pulling out other connections (and being unaware that you've done that), is to have a substitution box that terminates in a pair of insulated alligator clips.

All you need is a break-before-make single-pole rotary switch with as many positions as you need for the number of resistors or capacitors you're going to use. One end of the resistors gets connected to the poles on the rotary switch and the other ends are tied together and connected

to a clip lead. The only thing left to do is connect a clip lead to the selector pole on the rotary switch and you're in business.

If you do the same thing with capacitors, you'll have two things to worry about: one, the extra wiring and switches will change the capacitor values from what you might expect, and two, you should have some way to watch the polarity of the electrolytics and be sure to discharge them before you use the substitution box in a circuit. Remember that even a medium-sized electrolytic can store a healthy charge and, if the circuit you're working on is sensitive to capacitive discharges, you can do some real damage if you forget to discharge the capacitor before connecting it to the circuit.

All the things we've talked about here can be built in a minimum amount of time with a minimum amount of parts and brain damage. What you'll probably find, however, is that they'll be the most frequently used items on the bench. They aren't really test equipment in the strictest sense of the word but they'll make life a lot easier when you're working and that's definitely a good thing. Believe me.

There are lots of other, non-electronic, useful things you can put together that will make your bench time as productive as possible. Even

something as simple as a bunch of LED's, each with it's own current-limiting resistor, can be a handy tool to have around. It can save time rummaging through parts drawers, because one of the most basic rules on the bench is: The more you need something, the more time it takes to find it.

Now, I'm the first to admit that the things I've been talking about here aren't exactly of the "gee-whiz" variety, but that doesn't mean that you shouldn't take them seriously. A friend of mine works for Grumman and I used to visit him at work all the time when he was working on the Lunar lander. I know from personal observation that a lot of the final checks were done using an ordinary multimeter and a test light that was made from a single LED and a 1K resistor.

When we get together next month, we'll take a look at some test gear you can build that's a bit more interesting—electronically speaking. But keep in mind that, even though certain instruments are loaded with glitz and glitter, every instrument has it's own particular job—while it's true that you can't watch a waveform on an LED, it's also true that you can't use an oscilloscope to clean up a triggering pulse. Don't put down the really simple stuff just because it happens to be simple!

R-E

Audio amplifiers: Do they sound different?

LARRY KLEIN

When I first became involved with audio equipment in the 1950's, everything sounded different. In fact, it was difficult to get two samples of the same model phono cartridge, speaker, or even pre-amplifier that sounded identical. No one thought to complain because inconsistency was a basic fact of audio life at the time. We all knew that audio equipment was "touchy" as befitted finely tuned products engaged in pushing the state of the sonic art. The truth of the matter was that many of those early consumer-level audio products were badly designed, used low-grade parts, and were marketed without benefit of adequate quality control.

The sonic sixties

By the 1960's, audio equipment had gotten a lot better. When you first plugged in your new component, it usually worked; and if measured, it probably came within shooting distance of its rated specs. However, with the advent of transistorized equipment, quality took a nose dive. Audio buffs incautious enough to rush into the new technology encountered poor sensitivity and front-end overload in tuners; nonlinear inputs in phono preamps; overload, crossover distortion, and repeated failures in amplifiers. But after several years of solid-state travail, both reliability and sound quality substantially improved.

Do transistor amplifiers sound better or worse than their tubed counterparts? That question has been vehemently argued right up to the present by those who prefer the "warmth" of vacuum-tube sound to the sonic "sterility" of semiconductors. Technical limitations of the early semiconductors and their circuits frequently did cause sonic problems, but these were neither as inherent nor as inevitable as the tube lovers liked to believe. Today, there's no doubt, in my mind, at least, that audio

transistors can do anything tubes can do—and better!

Series impedance

Figure 1 shows the series impedance of a typical speaker hookup. Impedance Z_1 is the output impedance of the amplifier, Z_2 is the resistance in the speaker wire, and Z_3 is the complex impedance of a nominal 8-ohm speaker. The speaker impedance includes the crossover elements plus the impedance of the speaker, which typically varies widely

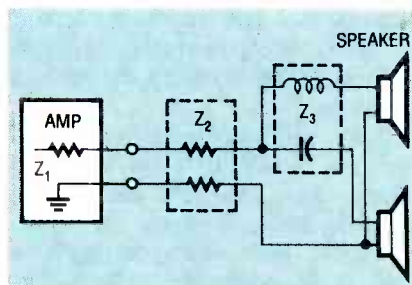

FIG. 1—THE IMPEDANCES FOUND in a typical speaker connection.

over the audio band. What we have, in effect, is a voltage divider where Z_1 and Z_2 usually add up to well under 1 ohm in contrast to Z_3 , which can vary with frequency between 3.5 and 40 ohms. Insofar as Z_1 and Z_2 are low, the amplifier is a constant voltage source across the audio band and the signal reaching the speaker is un-

affected. But if an amplifier has a high output impedance and/or the speaker wire is too thin, the speaker's normal impedance curve will be reflected by bumps and dips in the frequency response measured at the speaker terminals. See Fig. 2.

Although conventional wisdom states that a 1-dB variation is barely detectable, in reality the location and the Q (width) of ± 1 dips and peaks can affect many aspects of the perceived sound. Subjective qualities such as depth, openness, inner detail, harshness, wide/deep sound staging, and so forth are the ear/brain's responses to minor bumps and dips in various areas of the audio spectrum. Examples: A small rise in the octaves centered at 300 Hz will result in an enhanced sense of warmth and ambience because that's where ambience information is found in the concert hall and on recordings. Enhanced "definition" and "inner detail" result from boosts in the octaves centered around 4 kHz (as in Fig. 2) where the ear is most sensitive. And so forth.

Amplifier sound

Under what, if any, circumstances do amplifiers sound different from one another? Obviously, if an amplifier is driven into continuous clipping because of its limited power, a more powerful unit is likely to sound better.

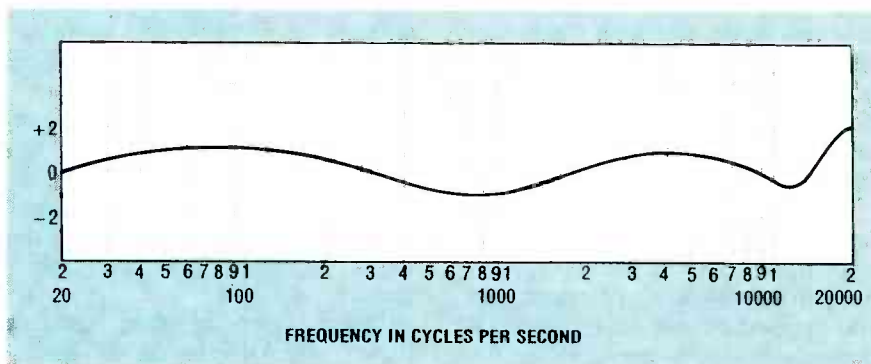

FIG. 2—TYPICAL FREQUENCY RESPONSE at the speaker terminals when Z_1 or Z_2 are high.



Make good money in a challenging career as a security electronics technician— even start a profitable new business of your own

All-new from NRI!

Now NRI trains you to be today's expert security electronics technician as you install and troubleshoot state-of-the-art security systems in your own home and auto.

Violent crime, theft, fire... they're facts of life in the U.S. today. But now there's good news, too. All across the nation people are fighting back with high-tech electronic security systems. In fact, Americans will spend over 17 billion dollars on security services and equipment by the year 1991.

For you, this new consumer demand for electronic security systems means even more good news. It means a breakthrough opportunity to get in on the ground floor of a booming new industry. Now, no matter where you live, you can start a high-paying career—even a business of your own—installing, servicing, and maintaining residential and commercial security systems.

Best of all, NRI's ready now to give you the hands-on security electronics training you need to get started fast.



You train with and keep a closed-circuit television camera, mount, and 9" monitor; state-of-the-art fire/intrusion alarm control panel with digital dialer; remote entry keypad; passive infrared motion detector; smoke detector; remote control auto alarm with motion detector, ignition disable relay, and siren; NRI Discovery Lab® for circuit demonstrations; and hand-held multimeter with 3 1/2 digit readout.

Right away, you get the skills you need to install and service all security systems
NRI's at-home Security Electronics training gives you solid electronics know-how, plus a complete working knowledge of popular security devices in use today.

You learn how to install and service magnetic contacts and pressure mats... microwave, ultrasonic, and passive infrared detectors... personal identification systems and electronic listening devices... even central station alarm systems and today's most sophisticated fire warning equipment. But that's not all.

Your hands-on training includes state-of-the-art CCTV equipment plus home and auto electronic alarm systems you keep
NRI gives you hands-on experience with today's newest, most popular security systems as you train with the professional closed-circuit television surveillance equipment and high-quality electronic home and auto alarm systems included in your course.

Step by step, you learn by doing... evaluating your own security needs, installing

complete electronic alarm systems in your own home and auto, testing and troubleshooting working alarm circuits. You actually safeguard your own property while gaining



Installing home security systems like this closed-circuit camera and monitor is just one way you can make money as a security electronics technician.

the expertise you need to move fast into an exciting career—even a business of your own—as today's expert security electronics technician.

Send for your FREE catalog today

For all the details about NRI's at-home Security Electronics training, send the coupon today. If the coupon is missing, write to NRI School of Electronics, McGraw-Hill Continuing Education Center, 4401 Connecticut Avenue, Washington, DC 20008.

NRI SCHOOL OF ELECTRONICS
McGraw-Hill Continuing Education Center
4401 Connecticut Avenue, Washington, DC 20008.



Check one catalog only

- | | | | |
|--|---|---|---|
| <input type="checkbox"/> Security Electronics | <input type="checkbox"/> Robotics | <input type="checkbox"/> Air Conditioning, Heating, and Refrigeration | <input type="checkbox"/> Small Engine Repair |
| <input type="checkbox"/> Computers and Microprocessors | <input type="checkbox"/> TV/Video/Audio Servicing | <input type="checkbox"/> Electrician | <input type="checkbox"/> Automotive Servicing |
| | <input type="checkbox"/> Basic Electronics | | <input type="checkbox"/> Locksmithing |

Name _____ Age _____

Address _____

City _____ State _____ Zip _____

Accredited Member National Home Study Council

For career courses approved under GI Bill check for details.

10-041

APRIL 1991

Or if an amplifier, because of poor design or malfunction, suffers from any of a number of well-understood circuit problems, it also can sound inferior to other better-designed products. But what accounts for the reported differences in sound quality among amplifiers that on the test bench are virtually distortion-free and have a ruler-flat response from infrasonic to ultrasonic frequencies?

Of course, most of the reported differences can be charged up to the overactive imaginations of devout audiophiles for whom the ability to detect such differences makes life worth living. But there are sometimes good technical reasons for the "mysterious" qualities heard by audiophile listeners.

The most meaningful way to measure an amplifier's frequency response is not as a black box, but as part of a system. Specifically, instead of graphing amplifier response across the standard 8-ohm resistive load (or the EIA-recommended complex load), measure the amplifier response across the terminals of a connected speaker system. With a

typical good-quality transistor amplifier, the frequency response will be the same measured at the amplifier and at the speaker terminals. This assumes that: (1) the amplifier has a low output impedance, (2) the speaker connecting wire is of heavy enough gauge to have reasonably low resistance for the length used, and (3) the speaker impedance curve doesn't fall into the basement at some frequencies. Interestingly enough, audiophile equipment sometimes fails to meet one or more of these criteria. Tube equipment, in particular, tends to have relatively high output impedances—up to perhaps 1.5 ohms.

Amplifier listening tests

How does all of the above square with the results of more than twenty published "blind" comparison listening tests? Basically, the tests have demonstrated repeatedly that so-called golden-ear audiophiles are not able to differentiate among amplifiers when they did not know which they were listening to. Since the effects discussed above occur only if the amplifier under test has a high output

impedance and the reference speakers have a non-flat impedance curve to interact with it, the vast majority of amplifiers are going to be indistinguishable from each other under any reasonable listening condition.

In a recent discussion with Bob Carver on the "Carver Challenge" (discussed in my December 1990 and March 1991 columns), he confided that the main change he made in his \$700 transistor amplifier to duplicate the sound of a \$10,000 tube unit was to add resistance in the transistor amp's output stage in order to mimic the tube unit's high output impedance. You can try it yourself using low-value 20-watt resistors or a pair of 2-ohm power rheostats. You need to add anywhere from 0.25 to 1.5 ohms resistance to your speaker lines depending upon your speakers and room acoustics. If you hit the required value, your conventional transistor amplifier will then magically have most of the special sonic qualities that audiophiles covet in their \$10,000 tube units. If you try the experiment, I'll be interested in how it works out.

R-E

LASER PRINTER

continued from page 17

sitive drum, the toner, and the motors to move the paper through the copier, we can convert a photocopier into a "laser printer" with relative ease.

To produce the image on the paper we simply need to place an image onto the copier which can be copied onto the paper. The copier will do the rest of the work for us.

Since a computer monitor is capable of high-resolution graphics, we will use a computer monitor strapped onto the copy machine to produce our image to be transferred to the paper.

Construction

The system can be built using a monochrome monitor. However, a VGA monitor should be used, as it has much better graphics resolution. The better the monitor, the better the final image.

Construction of the "laser printer" is accomplished by strapping the VGA monitor onto

the copy machine. Also the light bulb inside the copier must be removed. The computer monitor must be located on the glass surface of the copier so that it is lined up with the 8½- by 11-inch paper area.

The monitor can be secured to the copier surface using C clamps, superglue, or even large rubber bands or Bungee cords—the kind you use to strap things to the top of the car with, not the kind you jump off bridges with. The exact method used will depend on the copy machine and how easy the monitor can be secured to it. Figure 1 shows how we did it. Be sure that the cables to the monitor are not laying between the copier's glass surface and the monitor screen, and that they reach to your computer's video output. The monitor should not be glued into place until you have "laser" printed a few pages to check the alignment of the monitor on the copier glass. Once a few pages have been printed, and the monitor's alignment has been established as correct, then the monitor can be secured to the copier.

To remove the copier's light

bulb, open up the copier and find the bulb. It is usually located near the copier's glass surface, and may be accessible only by removing the copier's glass. The light bulb must be removed because the VGA monitor will now supply the light to expose the photosensitive drum. (The light is normally supplied by the light bulb reflecting off of the paper of the original.)

Usage

To test the "laser printer," put a graphics image onto the VGA monitor screen and simply press the COPY button. The image on the copier output paper should be a reproduction of the VGA image. Use several images to test the alignment of the VGA monitor, repositioning the monitor until the image is well centered. The monitor can then be secured to the copier.

Both text and graphics can be printed, with the only limits being those of the VGA display. Since copy machines can easily produce eight pages per minute, the "laser printer" is a very cheap alternative to purchasing a "real" one.

APR-1

The evolution of standards

JEFF HOLTZMAN

The following is a reply to the letter from Raymond Cheng of Ontario published in this month's "Letters" column:

Ten years is right. Technological innovations typically take ten years to attain widespread acceptance. And like it or not, the latest release of Windows has done more for promoting advanced computing environments than everything done by all the Amigas (and all the Macintoshes) put together over the past five or six years.

Why don't we provide more Amiga coverage? That's easy. Most **Radio-Electronics** readers use PC's. Further, electronics experimenters just don't seem to have much interest in the Amiga, so we get few article submissions for it. But if we did get any, and if they were any good, we would publish them. We're not anti-Amiga. We and our readers enjoy reading about alternate approaches. We have championed other "underdog" systems in the past; remember Peter Stark's series on the PT-68K?

As for the Amiga, I'm sure it's a worthy computer. But—evangelism and chauvinism aside—what effect has it had on the computer industry, and what innovations has it supplied? I don't believe that preemptive multitasking was invented at Commodore, nor was NTSC video, coprocessor-based I/O, the GUI, multimedia, and any of several other advanced architectural features. The Amiga wasn't even the first machine to combine several advanced architectural elements; take a look at the Xerox Star from the early 1980's, and many engineering workstations that were produced since then.

You might argue that the Amiga was the first low-cost computer with those features, and I'd agree with that. But so what? Here's my point about influence. The Amiga has had precious little influence thus far, and I feel certain that its position and Commodore's will only decline. Why

doesn't Commodore build a low-cost MS-DOS multimedia machine? That might save the company.

The original Macintosh was innovative, as is Job's latest brainchild, the Next. But neither has attracted significant market share, and Apple's continues its steady decline in the marketplace.

By contrast, the PC industry has seen a history of continual innovation in all facets of computer technology. The rate of innovation, combined with the concomitant lack of standards, has created many problems, some of which will be with us for many years. I'm sure Mr. Cheng would be more than willing to point out those faults for us, but he needn't bother: they're self-evident. And there are lots of very smart people working on solutions to those problems—more on this below.

Mr. Cheng, you can bash MS-DOS and the PC architecture all you want, but together they have changed the world. At best, the Amiga has maintained a spot on the periphery of the PC revolution.

Mr. Cheng, if you want to promote the Amiga, don't write a sarcastic letter to the Editor. Do something interesting with your machine, and then share it with us. We'll then get it in print.

P.S. Mr. Cheng: For your information, the value of acceleration in free fall (on Earth, anyway) is 32 **ft/sec²**, not **m/sec²**.

Standards and (r)evolution

Revolution, like parenthood, is messy. Every revolution starts as a radical shift away from an inadequate status quo. Then comes a period of uneasiness during which anything imaginable seems possible. The final stage is marked by the adoption of a new status quo, which thereby sets the stage for the cycle to repeat itself again.

The 80's represent the computer world's Boston Tea Party. Shots were

fired, ties were broken, new powers arose and seized control. Like the best revolutions, the computer revolution is a grass-roots affair. Individuals saw the power represented by the personal computer and grabbed it. Soon the world noticed that all those PC users were a force to contend with; the steady decline of the mainframe and minicomputer industries has been a shock mostly to those involved, not to those of us who've been involved with PC's from the very beginning.

In the grass-roots surge for power, however, something got lost in the shuffle: standards. When the revolution started, we knew only two things: that we needed personal computers and that we didn't want to do things the mainframe way. So we made things up as we went along. Doing so was good, in that it gave us a fresh slant on whatever it was that we wanted to do. But it also led to many of the difficult problems that PC and MS-DOS bashers love to use against us.

A couple of years down the road, it turns out that some mainframe/mini ways aren't so bad. It turns out that the mainframe and mini industries solved certain types of problems back in the 60's and 70's, and that those problems have come back to haunt us. Things like managing programs so large that they can't fit in available memory, things like running multiple programs simultaneously, things like intelligent I/O subsystems.

The difference now is one of focus. When we thought about virtual memory in the past, we associated it with mainframes. Now it's becoming clear to us that PC's need virtual memory as well. Likewise with multitasking, graphical environments, and all the rest.

You may think that we don't need those things. And you're right—as long as you think only in terms of doing things the way we learned to do

R-E Computer Admart

Rates: Ads are 2 1/4" x 2 1/8". One insertion \$995 each. Six insertions \$950 each. Twelve insertions \$925 each. Closing date same as regular rate card. Send order with remittance to Computer Admart, Radio-Electronics Magazine, 500-B Bi-County Blvd., Farmingdale, NY 11735. Direct telephone inquiries to Arline Fishman, area code-1-516-293-3000. FAX 1-516-293-3115. Only 100% Computer ads are accepted for this Admart.

ICs PROMPT DELIVERY!!!
SAME DAY SHIPPING (USUALLY)
QUANTITY ONE PRICES SHOWN FOR FEB. 3, 1991

Memory For Almost ALL Computers

DYNAMIC RAM

4M Board for hp LJ's w/2MB	\$160.00
SIMM 2M IBM PS/2 Model 70	145.00
SIMM 4Mx9 80 ns	285.00
SIMM 1Mx9 80 ns	49.00
4 Mbit 4Mx1 80 ns	38.00
4 Mbit 1Mx4 80 ns	47.00
1 Mbit 1Mx1 80 ns	5.25
41256 256Kx1 100 ns	2.40
41256 256Kx1 120 ns	2.30
44256 256Kx4 100 ns	5.75
4464 64Kx4 100 ns	1.95

EPROM

27C4001 512Kx8 150 ns	\$55.00
27C1000 128Kx8 200 ns	14.00
27C512 64Kx8 120 ns	8.50
27256 32Kx8 150 ns	6.75
27128 16Kx8 250 ns	3.65

STATIC RAM

1 Mbit 128Kx8 100 ns	\$15.00
62256LP 32Kx8 100 ns	6.95

OPEN 6' - DAYS, 7:30AM-10PM SHIP VIA FED-EX ON SAT.

SAT DEL ON FEB-EX ORDERS RECEIVED BY: 24,000 S. Florida Ave., BEGGS, OK 74421

MasterCard VISA or UPS CASH COD
MICROPROCESSORS UNLIMITED, INC.
24,000 S. Florida Ave., (918) 267-4961
No minimum order. Please note: prices subject to change
Shipping, insurance extra; up to \$1 for packing materials

80387-25 80387-33 80387-35 80387-16 80387-20 80387-25 80387-2 80387-8 80387-10 80387-12 80387-14 80387-18 80387-22 80387-24 80387-26 80387-28 80387-30 80387-32 80387-34 80387-36 80387-38 80387-40 80387-42 80387-44 80387-46 80387-48 80387-50 80387-52 80387-54 80387-56 80387-58 80387-60 80387-62 80387-64 80387-66 80387-68 80387-70 80387-72 80387-74 80387-76 80387-78 80387-80 80387-82 80387-84 80387-86 80387-88 80387-90 80387-92 80387-94 80387-96 80387-98 80387-100

SECRETS OF THE COMMODORE 64

BP135—A beginners guide to the Commodore 64 presents masses of useful data and programming tips, as well as describing how to get the best from the powerful sound and graphics facilities. We look at how the memory is organized, random numbers and ways of generating them, graphics-color-and simple animation, and even a chapter on machine code. Get your copy today. **Send \$5.00 plus \$1.25 for shipping** in the U.S. to **Electronic Technology Today Inc., P.O. Box 240, Massapequa Park, NY 11762-0240.**



GETTING THE MOST FROM YOUR PRINTER

Getting The Most From Your Printer



BP181—It is probable that 80% of dot-matrix printer users only ever use 20% of the features offered by their printers. This book will help you unlock the special features and capabilities that you probably don't even know exist. To order your copy **send \$6.95 plus \$1.50 for shipping** in the U.S. to **Electronic Technology Today Inc., P.O. Box 240, Massapequa Park, NY 11762-0240.**

CIRCLE 61 ON FREE INFORMATION CARD

them during the 80's. The problem is that the 80's way was only a first approximation, a first step toward solving the real problems in our ever-changing world.

It's not really very important whether F1 represents Help and F10 Exit; The real problem is how to model the real world in a useful way. The problem is not how to put italic text on screen and on paper, but how to represent real documents in the full richness with which they appear in everyday life. The problem is not how to build educational software, but how to build software that is fun, and by the way educational. The problem is not how to build real-time systems with a certain response rate and throughput, but how to build real-time systems that can adapt to changing real-world conditions.

Ultimately, the problem is not how to do the same old things in the same old ways, but how to do them in a faster or cheaper way. The real problem is to learn how to focus on our real problems, which will of necessity entail inventing new ways of doing things.

For example, we don't just want to learn how to make cars cheaper. We need to learn how to respond to what customers want, when they want it, and in a quality manner.

Enough. All this is about the PC revolution.

The next step

The biggest problem facing the PC industry is not that the PC isn't an Amiga or a Mac or a SparcStation or a MicroVAX or a you-name-it. The biggest problem isn't that the PC industry is ten years behind. The real problem is standards: the lack of standards, the need for standards, the difficulty of achieving meaningful standards before they become outdated (witness the S-100 bus), standards that are flexible enough to accommodate future innovation, and the difficulty of reconciling the standards we need with our ability to pay for them.

Until we solve those problems, things will be chaotic, so we will waste huge amounts of time and effort resolving incompatibilities. Meanwhile, Europe and Japan continue their steady creep with their advancing technologies.

In some ways, we need standards more than innovation. In the case of competing standards, we need standard ways of bridging incompatibilities. We need simple, transparent ways of sharing documents, whether the source is Word, MacWrite, PageMaker, or AmigaT_EX; of sharing files across operating systems; of integrating diverse platforms (PC, Mac, workstations, even Amigas) on a network; and of displaying fonts on screen and on paper. We

need to easily send Email across the office, across the country, or across the world. We need to quickly get at on-line data. We need simple, transparent ways of performing system backups; upgrading system software, even while it's running; and integrating data in all the forms that nature provides. We need a cheap multimedia machine with a megapixel display, megabytes of memory, preemptive multitasking, an easy-to-use operating-system shell, and enough intelligence to start doing the kinds of work computers are supposed to do, so that we can spend less time housekeeping and more time doing the kinds of work we're supposed to do.

It is beyond the capability of any single U.S. company to solve most of those problems. If solutions are to be had, they must come about through a modified, cooperative form of competition. It's great that Lotus and Borland compete over spreadsheets like tigers in a cage. But they must remember that customers buy holes, not drill bits. In other words, customers buy solutions, not technologies. Customers won't buy Quattro because it's "better" than 1-2-3; they will buy it if it solves their problems better. Or they should. And that brings us to the other side of the coin: customer education.

Customers are lazy, especially in

this country. Many people think that once they've learned one way of doing something, they should never have to learn another. They think that they should only have to pay their dues once. Because of the way technology is evolving, however, that's a very unhealthy attitude. Just because you've learned 1-2-3 or WordPerfect, that doesn't give you the right to forever forsake learning any other package. If you as an individual want to be successful, you should also take it upon yourself to learn Word, WordStar, Quattro, Excel, and every other package you can get your hands on. Until software has become as standardized as open-end wrenches, you'll only enhance your worth in the job market by learning everything you can about everything you can get your hands on—and I don't mean just word processors and spreadsheets; the same principle applies, regardless of the tools of your particular trade.

We don't have the standards we need; likely it will take another decade or longer for all the pieces to fall into place. In the meantime, we as a country must remain flexible enough to roll with the punches. And if that

means learning WordStar today, WordPerfect tomorrow, and Word next week, so be it. The point is that we've got to get to the point where it's worth standardizing, and leave it at that.

Emerging standards

Several standards are lurking just beyond the horizon. What are they? How do they impact us today? How will they impact us tomorrow?

Take a look at Fig. 1. That diagram goes by various names, but it is commonly known as the "Toaster Diagram" because of its resemblance to an old-fashioned toaster. Advanced thinkers in the U.S. and Europe use the Toaster Diagram as a conceptual model for the Computer Aided Software Engineering (CASE) environment of the future. The idea is to provide a basic framework of common computer services into which you may drop customization modules like slices of toast.

The framework consists of a base communications layer through which all the "slices" communicate. The front slice is the user interface, by means of which we communicate with the system. Parallel slices pro-

vide data and task management; orthogonal slices provide "slots" into which special-purpose tools fit.

That's the vision of where CASE tools are going. But it doesn't take a whole lot of thought to recognize that that type of model may be useful wherever disparate tools and data must work in concert.

In fact, the framework-with-installable-modules idea is becoming pervasive. Windows, for example, provides a framework with a basic set of services, including a user interface, the ability to launch and supervise programs, file and data management. You can install your own slices (word processors, spreadsheets, etc.), and make them work together via Dynamic Data Exchange (DDE). Never mind that Windows is flawed; the framework is what's important. DDE is weak, but it proves the principle. And Microsoft is working on extensions called Object Linking and Embedding (OLE).

You can do similar things in other environments.

What's needed then is a set of standards that extends the framework metaphor across networks and platforms. That's when we'll reach the third stage of the revolution. That's when we'll be able to include Mr. Cheng's Amiga text file with a Mac file from the art department with some specs from the UNIX-based engineering group...

Did I mention UNIX? Still think it's a dirty word?

DOS + Windows is evolving toward OS/2. OS/2 includes by design virtually every advanced feature of virtually every advanced operating system, including UNIX. OS/2 is evolving toward POSIX, an IEEE standard that is rapidly becoming the standard for UNIX-like operating systems. Other mainframe and mini operating systems will be POSIX-compliant soon as well. POSIX is nothing if not an operating-system framework in the sense used above.

If everything else is evolving toward POSIX, where does that leave the 60-million DOS-based PC's? And what about the Macs and Amigas? And why is Motorola's share of the CPU market expected to drop from 25% to 17% this year?

I don't have answers to those questions. But if you think you have some answers feel free to write c/o the magazine.

R-E

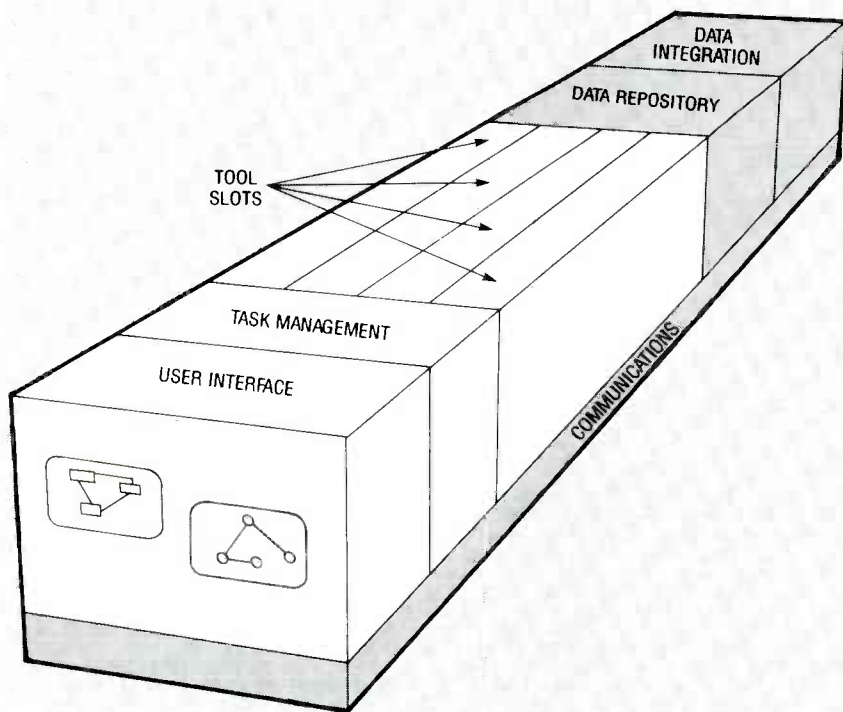

FIG. 1—THIS IS COMMONLY KNOWN as the "Toaster Diagram" because of its resemblance to an old-fashioned toaster. Advanced thinkers in the U.S. and Europe use the diagram to illustrate the basic framework of common computer services into which you may drop customization modules like slices of toast.

MARKET CENTER

FOR SALE

DESCRAMBLERS. All brands. Special: Combo Jerrold 400 and SB3 \$165.00. Complete cable descrambler kit \$39.00. Complete satellite descrambler kit \$45.00. Free catalog. **MJM INDUSTRY**, Box 531, Bronx, NY 10461-0208.

ENGINEERING software, PC/MSDOS. Hobbyists — students — engineers. Circuit design and drawing, PCB layout, Logic simulation, FFT analysis, Mathematics, Circuit analysis. Call or write for free catalog. 1 (800) 728-3805, **BSOFT SOFTWARE**, 444 Colton Rd., Columbus, OH 43207.

RESTRICTED technical information: Electronic surveillance, schematics, locksmithing, covert sciences, hacking, etc. **Huge selection. Free brochures.** **MENTOR-Z**, Drawer 1549, Asbury Park, NJ 07712.

CABLE TV DESCRAMBLERS! BARGAIN HEADQUARTERS!



- JERROLD™ •TOCOM •HAMLIN
- OAK •ZENITH
- SCIENTIFIC ATLANTA

6 month warranty! We ship C.O.D.!
Lowest retail/wholesale prices!

FREE CATALOG:
Global Cable Network
1032 Irving St. Suite 109
S.F., CA 94122
NO CALIFORNIA SALES!!!

ORDER TODAY! 800-327-8544

CABLE TV converters: Jerrold, Oak, Scientific Atlantic, Zenith & many others. "New MTS" stereo add-on: mute & volume. Ideal for 400 and 450 owners! 1 (800) 826-7623, Amex, Visa, M/C accepted. **B & B INC.**, 4030 Beau-D-Rue Drive, Eagan, MN 55122.

TUBES, new, up to 90% off, SASE, **KIRBY**, 298 West Carmel Drive, Carmel, IN 46032.

WIRELESS CABLE RECEIVERS 1.9 TO 2.7 GHz



30 CH PARABOLIC DISH SYSTEM \$173.90
30 CH ROD ANTENNA SYSTEM \$193.90
30 CH CRYSTAL CONTROLLED SYSTEM \$294.95
SUN MICROWAVE INT'L. INC. SEND \$1.00 FOR P.O. BOX #34522 CATALOG ON THESE PHOENIX, AZ 85067 AND OTHER FINE (602) 230-0640 VIDEO PRODUCTS
QUANTITY DISCOUNTS

VISA/MC/AMEX

CABLE converters — descramblers, lowest prices — best quality, Tocom 5503A \$199.00, Sylvania 4040 better than Jerrold 400-DIC, exact replacement \$95.00, Oak RTC-56 \$150.00, Hamlin combo \$125.00, Zenith Z-tac \$225.00, all come with hand held remote, SA-3-B descrambler \$79.00, Tri-bi descrambler (super-fast) \$79.00, MLD-1200 descrambler \$49.00. C.O.D. orders accepted, quantity discounts — 10% off on 5 or more, 20% off on 10 or more. All products fully warranted. **S.A.C.**, 1 (800) 622-3799. Hours M-F 7AM-3PM P.S.T.

TUBES: "oldest," "latest." Parts, schematics. SASE for lists. **STEINMETZ**, 7519 Maplewood Ave., RE, Hammond, IN 46324.

T.V. notch filters, phone recording equipment, brochure \$1.00. **MICRO THinc.**, Box 63/6025, Margate, FL 33063. (305) 752-9202.

CLASSIFIED AD ORDER FORM

To run your own classified ad, put one word on each of the lines below and send this form along with your check to:

Radio-Electronics Classified Ads, 500-B Bi-County Boulevard, Farmingdale, NY 11735

PLEASE INDICATE in which category of classified advertising you wish your ad to appear. For special headings, there is a surcharge of **\$25.00**.

Plans/Kits Business Opportunities For Sale
 Education/Instruction Wanted Satellite Television

Special Category: \$25.00

PLEASE PRINT EACH WORD SEPARATELY, IN BLOCK LETTERS.

(No refunds or credits for typesetting errors can be made unless you clearly print or type your copy.) Rates indicated are for standard style classified ads only. See below for additional charges for special ads. **Minimum: 15 words.**

1	2	3	4	5
6	7	8	9	10
11	12	13	14	15 (\$46.50)
16 (\$49.60)	17 (\$52.70)	18 (\$55.80)	19 (\$58.90)	20 (\$62.00)
21 (\$65.10)	22 (\$68.20)	23 (\$71.30)	24 (\$74.40)	25 (\$77.50)
26 (\$80.60)	27 (\$83.70)	28 (\$86.80)	29 (\$89.90)	30 (\$93.00)
31 (\$96.10)	32 (\$99.20)	33 (\$102.30)	34 (\$105.40)	35 (\$108.50)

We accept MasterCard and Visa for payment of orders. If you wish to use your credit card to pay for your ad fill in the following additional information (Sorry, no telephone orders can be accepted.):

Card Number

Expiration Date

Please Print Name

Signature

IF YOU USE A BOX NUMBER YOU MUST INCLUDE YOUR PERMANENT ADDRESS AND PHONE NUMBER FOR OUR FILES. ADS SUBMITTED WITHOUT THIS INFORMATION WILL NOT BE ACCEPTED.

CLASSIFIED COMMERCIAL RATE: (for firms or individuals offering commercial products or services) \$3.10 per word prepaid (no charge for zip code)...**MINIMUM 15 WORDS.** 5% discount for same ad in 6 issues; 10% discount for same ad in 12 issues within one year; if prepaid. **NON-COMMERCIAL RATE:** (for individuals who want to buy or sell a personal item) \$2.50 per word, prepaid...no minimum. **ONLY FIRST WORD AND NAME** set in bold caps at no extra charge. Additional bold face (not available as all caps) 55c per word additional. Entire ad in boldface, \$3.70 per word. **TINT SCREEN BEHIND ENTIRE AD: \$3.85 per word. TINT SCREEN BEHIND ENTIRE AD PLUS ALL BOLD FACE AD: \$4.50 per word. EXPANDED TYPE AD: \$4.70 per word prepaid.** Entire ad in boldface, \$5.60 per word. **TINT SCREEN BEHIND ENTIRE EXPANDED TYPE AD: \$5.90 per word. TINT SCREEN BEHIND ENTIRE EXPANDED TYPE AD PLUS ALL BOLD FACE AD: \$6.80 per word. DISPLAY ADS:** 1" x 2 1/4"—\$410.00; 2" x 2 1/4"—\$820.00; 3" x 2 1/4"—\$1230.00. **General Information:** Frequency rates and prepayment discounts are available. **ALL COPY SUBJECT TO PUBLISHERS APPROVAL. ADVERTISEMENTS USING P.O. BOX ADDRESS WILL NOT BE ACCEPTED UNTIL ADVERTISER SUPPLIES PUBLISHER WITH PERMANENT ADDRESS AND PHONE NUMBER.** Copy to be in our hands on the 5th of the third month preceding the date of the issue. (i.e., Aug. issue copy must be received by May 5th). When normal closing date falls on Saturday, Sunday or Holiday, issue closes on preceding working day. Send for the classified brochure. Circle Number 49 on the Free Information Card.

Quality Microwave TV Antennas

WIRELESS CABLE - IFTS - MMDS - Amateur TV
Ultra High Gain 50db(+) • Tuneable 1.9 to 2.7 Ghz.

- 36-Channel System Complete \$149.95
- 12-Channel System Complete \$114.95
- Call or write (SASE) for "FREE" Catalog

PHILLIPS-TECH ELECTRONICS
P.O. Box 8533 • Scottsdale, AZ 85252
(602) 947-7700 (\$3.00 Credit all phone orders)
MasterCard • Visa • COD's • Quantity Pricing

LIFETIME WARRANTY

TUBES Sylvania 6LQ6, 6L6GC, 20LF6 etc. Huge discounts. **ARLEN SUPPLY**, 7409 West Chester Pike, Upper Darby, PA 19082. 1 (800) 458-1301.

CB Tune-up manual Volume II & III. Specific model information for peaking 23's, 40's, and export CB's. \$19.95 each or (217) 466-4210 to order. Charge-card, C.O.D. accepted. **THOMAS DISTRIBUTING**, 127-R Westwood, Paris, IL 61944.

INTERFERENCE filters, all channels. Best quality, cylinder type. Best prices. Visa, MC, COD accepted. Large quantities available. **VIKING FILTERS**, 1 (800) 872-5912.

CB RADIO OWNERS!

We specialize in a wide variety of technical information, parts and services for CB radios. 10-Meter and FM conversion kits, repair books, plans, high-performance accessories. Thousands of satisfied customers since 1976! Catalog \$2.

CBC INTERNATIONAL
P.O. BOX 31500RE, PHOENIX, AZ 85046

TOCOM VIP converters w/remote from \$279.00. Tocom super chips turn on everything, \$69.00 each. Phone (219) 935-4128.

FM 2-way, CB/amateur, scanners, radar detectors, auto alarms, catalog \$2.00, RAYS, PO Box 14862, Fort Worth, TX 76117.

CABLE TV converters and descramblers. We sell only the best. Low prices. **SB-3 \$79.00.** We ship C.O.D. Free catalog. **ACE PRODUCTS**, PO Box 582, Dept. E, Saco, ME 04072. 1 (800) 234-0726.

PRINTED circuit boards etched & drilled. Free delivery. **K & F ELECTRONICS, INC.**, 33041 Groesbeck, Fraser, MI 48026. (313) 294-8720.

CABLE descramblers (Jerrold) from \$40.00. Tocom VIP test chip. Fully activates unit. Also Zenith test board. Fully activates Z-Tacs. \$50.00. Call (213) 867-0081.

FREE CATALOG

FAMOUS "FIRESTIK" BRAND CB ANTENNAS AND ACCESSORIES. QUALITY PRODUCTS FOR THE SERVIDUS CB'er. SINCE 1962

FIRESTIK ANTENNA COMPANY
2614 EAST ADAMS
PHOENIX, ARIZONA 85034

TEST equipment pre-owned now at affordable prices. Signal generators from \$50.00, oscilloscopes from \$50.00, other equipment, including manuals available. Send \$2.00 U.S. for catalog, refunded on 1st order. **J.B. ELECTRONICS**, 3446 Dempster, Skokie, IL 60076. (708) 982-1973.

CABLE TV converters & descramblers for Jerrold and Scientific Atlanta. Low prices, one year warranty. We ship COD. **BAY STATE ELECTRONICS**, PO Box 103, Boston, MA 02188. 1 (800) 359-9806.

CAR stereos, equalizers, amplifiers, speakers, woofers, tweeters, speaker box supplies, alarms, DJ mixers, more. Large catalog \$1.00. **ELECTRISONIC-K1**, 8400 Alameda, El Paso, TX 79907.

CABLE T.V. CONVERTERS
WHY PAY A HIGH MONTHLY FEE?

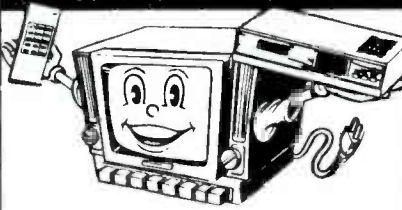

All Jerrold, Oak, Hamlin, Zenith, Scientific Atlanta, Magnavox and all specialized cable equipment available for shipment within 24 hours. For fast service MC / VISA or C.O.D. telephone orders accepted (800) 648-3030 60 Day Guarantee (Quantity Discounts) 8 A.M. to 5 P.M. C.S.T. **CLOSED WEEK-ENDS.** Send self-addressed Stamped envelope (60¢ postage) for Catalog.

MIDWEST ELECTRONICS INC. P.O. Box 5000 Suite 311 (R) Carpentersville, IL 60110

No Illinois Orders Accepted.

DESCRAMBLER — converters, all name brands at wholesale prices, Oak RTC-56 \$150.00, Tocom 5503A \$179.00, 4040 with integrated Hamlin descrambler \$125.00, 4040 with integrated SB descrambler \$95.00, Zenith Z-tac \$225.00, all with remote control, SA3B-Tri-Bi (superfast) \$79.00, M35B \$39.00, C.O.D. orders O.K. **MOUNT HOOD ELECTRONICS**, (503) 253-0459.

GOV'T seized surplus vehicles available from \$100.00! Call for immediate information (504) 649-5745 ext. S-5192.

PERFECT CABLE CONNECTION !!

Perfect Cable Connection is totally committed to customer satisfaction. Our primary concern is to provide you with the highest quality converters and descramblers at the lowest cost. We employ full time technicians to insure hassle free service and troubleshoot any situation. Call us today and let us prove to you why we are the Perfect Cable Connection.

- 6 months 100% parts & labor
- 24 months warranty available
- Full technical support
- On-line computer system
- 30 days money back guarantee
- Most orders shipped within 24 hours
- Visa, M.C. AMEX - 5%
- Dealers welcome
- C.O.D.

Jerrold 400 DRX 3 DIC WR 1 119 5 89 10 79 20 69 50 65 100 CALL	SA 8536 W R 1 225 5 205 10 185 20 170 50 CALL 100 CALL	Regal RC 83 W R 1 89 10 69 20 65 50 60 100 55	"New" • 99 Ch capacity • Wireless remote • Automatic fine tuning • Parental lock • Made in Japan • Super small • Favorite memory channels	Ch. M35B 3 or 2 1 39 5 35 10 30 20 27 50 CALL 100 CALL
Filters 1 CALL 10 CALL 5 CALL 20 CALL 50 CALL 100 CALL	Jerrold 450 DRZ 3 DIC W R 1 129 5 99 10 89 20 79 50 CALL 100 CALL	SA 8500-311 W R 1 199 5 175 10 150 20 CALL 50 CALL 100 CALL	Zenith ZTACS All models Call for prices	CRX 5000 3M W R 1 119 5 99 10 79 20 69 50 CALL 100 CALL
Jerrold 400 DRX 3105 W R 1 55 5 49 10 45 50 40	TB-3 1 75 10 48 20 43 50 39 100 35	SA-3B 1 75 10 48 20 43 50 39 100 35	Jerrold 450 DRZ 3 W R 1 68 10 55 20 45 50 40	FTB-3 1 99 10 79 20 65 50 CALL 100 CALL

WE WILL MEET OR BEAT ANY ADVERTISED PRICE IN THIS MAGAZINE.

PERFECT CABLE CONNECTION

702-358-2763
2209 Oddie Blvd., Suite 321
Spark, NV 89431

CABLE TV

TB-3 (Tri-Bi) or SA-3

Quantity Prices

10	20
\$48. Each	\$43. Each
50	100
\$39. Each	\$35. Each

Hours open 10:00 am to 4:00 pm Eastern time
Minimum order 5 units 55.00 ea.
Dealers wanted. We ship COD.

King Wholesale
1-800-729-0036
Fax number 6173400053

"No one beats the King's prices!"

DESCRAMBLERS

APRIL 1991

Cable Descramblers

New Auto Tri-Bi guaranteed no flashing \$165.00

SB-3.....	\$99.00	ZENITH SUPER	
TRIMODE.....	\$109.00	SAAVI.....	\$199.00
HAMLIN.....	\$99.00	TOCOM.....	\$319.00
SCIENTIFIC-		EAGLE.....	\$119.00
ATLANTA.....	\$119.00	COPY GUARD.....	\$59.95
OAK M35B.....	\$99.00	STARGATE 2000.....	\$88.00
ZENITH.....	\$175.00		

M.D. Electronics will match or beat any advertised wholesale or retail price.

Your best buys and warranties for cable converters and descramblers start with a FREE catalog from MD

For Information Call

402-554-0417

To order or request a free catalog

1-800-624-1150

M.D. ELECTRONICS

875 SO. 72nd St.
Omaha, NE 68114

BY ORDERING CABLE TV EQUIPMENT FROM M.D. ELECTRONICS THE PURCHASER AGREES TO COMPLY WITH ALL STATE AND FEDERAL LAWS REGARDING PRIVATE OWNERSHIP OF CABLE TV EQUIPMENT. IF YOU ARE UNSURE OF THESE LAWS CHECK WITH YOUR LOCAL OFFICIALS.

CIRCLE 53 ON FREE INFORMATION CARD

EXCELLERATOR™ Series

CABLE CONVERTERS

WHEN QUALITY COUNTS



New Dynatrack™ fine tuning provides unmatched picture quality
550 Mhz tuner provides 83 channel capacity
Sleep timer for automatic shut off within 15-90 minutes
2/3 switchable IIRC / IRC / Standard Switchable
2 Year warranty, Last channel recall, Favorite channel select, Scan
Double vented high efficiency transformer for cool performance
Stargate-2001 \$99.00
Stargate-550XL \$119.00 With Volume Control

Don't settle for anything less.



C.O.D.

REMOTE CONTROL KEYCHAIN



Complete w/mini-transmitter and +5 vdc RF receiver
Fully assembled including plans to build your own auto alarm
Quantity discounts available

\$24.95 Check, Visa or M/C
Add \$ 3 shipping

VISITECT INC. BOX 5442, SO. SAN FRAN., CA. 94080
(415) 872-0128 Fax (415) 872-2635

PCB and schematic CAD software. Easy multilayer rubberband zoom pan and more. CGA EGA IBM compatibles. \$195.00. **NUMBER ONE SYSTEMS**, 10565 Bluebird Street, Coon Rapids, MN 55433. Demo Disc. (612) 757-8584.

SURVEILLANCE — Audio/video/infra-red/laser equipment. Industrial or private. 500 item catalog \$7.00. **SECURITY SYSTEMS**, 3017G Hudson, New Orleans, LA 70131.

BUILD from easy-to-follow schematics: audio mixers/equalizers (stage, studio, business, home, basic to sophisticated), feedback controllers, active filters, guitar super-fuzz box, loudspeaker enclosures (including car/van), power supplies, more. vSSE reliability. Send \$5.00 for descriptions. Reasonable prices. **VON SPRECKEN SOUND ENGINEERING**, Dept. B, Box 1315, Clinton, MS 39060.

DIGITAL V.O.M./D.P.M. SALES—SERVICE—PARTS

FLUKE-BECKMAN-SIMPSON-ETC.

U.S. MADE ONLY. QUOTATION PRIOR TO WORK. FAST SERVICE. 90 DAY WARRANTY. STANDARDS TRACEABLE TO NBS. SINCE 1948. CALIBRATION CERTIFICATE AVAILABLE

INDUSTRIAL INSTRUMENT WKS. INC.
5745 SALMEN, HARAHAN, LA 70123 504-733-8355

HOW TO use surface mount techniques. Build ultra miniature projects. Included free, two sets plans. Infra red remote control, and light display. Send \$15.00 to **CHARLIE'S VIDEO**, Dept. SMT, PO Box 7782, LaSierra, CA 92503

HYPNOTIZE or relax electronically! Alpha/meditation goggles. Complete kit \$53.00. Free information. **MARK WORLEY**, Box 261113, San Diego, CA 92196.

PEN Transmitter: Sensitive micro FM transmitter housed inside standard size pen. Latest surface mount technology. Complete kit and instructions \$44.95. **MICRONIC-INT.**, Box 5726, Sherman Oaks, CA 91413

DISCOUNT computer books: Thousands of titles available. Including recent releases. Please call or write for our free catalog. **BOOKWARE**, 344 Water-town Road, Thomaston, CT 06787. 1 (800) 288-5662. (203) 283-6973.

STOP prank phone calls Electronic device displays phone number of person calling you, \$89.95 (assembled), brochure \$1.00, surveillance catalog, \$5.00. **EDE**, POB 337, Buffalo, NY 14226.

LASERS



New Laser Diodes \$15

Helium-Neon Laser Tubes from \$25



COMPLETE HELIUM-NEON LASERS FROM \$59.00

FREE CATALOG Call or Write Today!

MEREDITH INSTRUMENTS PO Box 1724/Glendale AZ 85311/(602) 934-9387

PCB and SCHEMATIC C.A.D.

EASY-PC



\$195

Now even faster and with Laser Printer Output.

- Runs on PC/NT/AT/286/386 with CGA EGA or VGA.
- Design Single sided, Double sided and Multilayer boards.
- Provides Surface Mount support.
- Standard output includes Dot Matrix / Laser / Inkjet Printer, Pen Platter, Photo-platter and N.C. Drill.
- Award winning EASY-PC is in use in over 7000 installations in 50 countries world-wide.
- SUPERBLY EASY TO LEARN AND USE.
- Not Copy Protected.
- Dealers Wanted.

FAST Professional Quality Output at an Affordable Price

For full info, write, fax, call or use Inquiry #

Number One Systems Ltd. 1

REF: REUS, HARDING WAY, ST.IVES, HUNTINGDON, CAMBS, ENGLAND, PE17 4WR.

Telephone:	Fax:	AMEX, VISA,
USA: 011-44-480-61778	USA: 011-44-480-494042	
Intl: +44-480-61778	Intl: +44-480-494042	MasterCard
UK: +480 61778	UK: +480 494042	Welcome

PRO 400

AC/DC VOLTAGE
AC/DC CURRENT
DIODE TEST Stock No
LOGIC TEST 990092
LED TEST GOOD/BAD
5 FREQ RANGES
5 CAPACITANCE RANGES
LOW BATTERY Warning
CONTINUITY TEST/BUZZER
TRANSISTOR CHECKER
20 MHZ FREQ COUNTER

\$69.95

30 DAY MONEY BACK GUARANTEE!

KELVIN Electronics VISA M/C

7 Fairchild Ave. Plainville, NY 11803
(516) 349-7620 1(800) 645-9212
FAX (516) 349-7830



PLANS AND KITS

CATALOG: hobby/broadcasting/HAM/CB: Cable TV, transmitters, amplifiers, surveillance devices, computers, more! **PANAXIS**, Box 130-F4, Paradise, CA 95967.

INVESTIGATORS, experimenters — Quality new plans. Micro and restricted devices. Free catalog. Self addressed stamped envelope required **KELLEY SECURITY INC.**, Suite 90, 2531 Sawteite Blvd., Los Angeles, CA 90064.

LASER lighting entertainment systems and accessories. Create 3-dimensional laser light shows with these professional secrets! Electronic and mechanical designs for all budgets! \$20.00. **MILLENNIUM**, 229 McAfee, Thousand Oaks, CA 91360.

DAZER II personal protection device! Plans \$8.00. Lasers! Transmitters! Detectors! More! Kits or assembled! Catalog \$2.00. **QUANTUM RESEARCH**, 16645-113 Avenue, Edmonton, Alberta T5M 2X2.

PC/TV interface — RGB to TV/Video/VCR. Switchable between PC and composite video inputs. Channels 3 or 4. RF output. Complete PC card kits \$59.95. PC board only \$19.95. **INNOVONICS CORP.**, 9 Bartlett St., Dept. 36, Andover, MA 01810.

DESCRAMBLING, new secret manual. Build your own descramblers for cable and subscription TV. Instructions, schematics for SSAVI, gated sync, sinewave, (HBO, Cinemax, Showtime, UHF, adult) \$12.95, \$2.00 postage. **CABLETRONICS**, Box 30502R, Bethesda, MD 20824.

POWERFUL single-chip FM voice transmitter, size of a postage stamp, transmits to any FM radio up to one mile away. Complete kit \$19.95 postpaid. **HERTZ MICRODEVICES**, Box 41771-A, LA, CA 90041-41771.

FLOODED basement due to a sump pump or float switch defect? Prevent it with the **Automatic Sump Pump Controller** with alarm. Complete plans \$6.00 (\$10.00 for dual controller plans for backup pump). **ALDIS INDUSTRIES**, Box 208, Burlington, MA 01803.

SURFACE Mount technology: Learn to build your own SMT projects, concise tutorial by leading expert. Component supplier listings, \$24.00. **CIS**, 1836 North Fifth Place, PortHueneme, CA 93041.

SURVEILLANCE electronics, plans, kits, assembled. Catalog \$4.00. **S & S ELECTRONICS**, PO Box 36505-123R, San Jose, CA 95158.

CABLE TV "BOXES"

Converters — Descramblers
Remote Controls — Accessories

- ★ Guaranteed Best Prices ★
- ★ 1 Year Warranty — C.O.D.'s ★
- ★ Immediate Shipping ★
- ★ FREE CATALOG ★

Call or Write
TRANS-WORLD CABLE CO.

12062 Southwest 117th Court, Suite 126
Miami, Florida 33186
1-800-442-9333



SRVEILLANCE transmitter kits! Four models of each; telephone, room, combination telephone/room transmitters tune from 65 to 305 MHz. Catalog with **Popular Communications and Popular Electronics** book reviews of "Electronic Eavesdropping Equipment Design," \$1.00. **SHEFFIELD ELECTRONICS**, 7223 Stony Island Ave., Chicago, IL 60649-2806.

The complete manual of pirate radio with schematics. Send \$5.95 plus \$1.00 postage. **ACME ENTERPRISES**, 1356 Coney Island Ave., Suite 200 G, Brooklyn, NY 11230.

PAY TV AND SATELLITE DESCRAMBLING 1991 EDITION

The very latest information! Turn-ons, bypasses, build-your-own ECM's, sources, etc. for cable, satellite and wireless. Only \$14.95. Pay TV and Satellite Descrambling (basics) Vol. 1, \$14.95. Pay TV and Satellite Descrambling V. 1989 (advanced) \$14.95. Build Satellite Systems Under \$600. \$12.95. Wireless Cable Handbook \$9.95. Any 3 \$29 or \$342. Scrambling News monthly. This month a complete report on the blackpippers which descramble VCI, VCI PLUS, B-MAC and Orion. Catalog \$1.

Scrambling News, 1552 Hertel Ave., Buffalo, NY, 14216. COD'S ARE OK. (716) 874-2088

SATELLITE TV

FREE catalog — Lowest prices worldwide, save 40—60%. Systems, upgrades, parts, all major brands factory fresh and warranted. **SKYVISION**, 2009 Collegeway, Fergus Falls, MN 56537. 1 (800) 334-6455.

CABLE TV secrets — the outlaw publication the cable companies tried to ban. HBO, Movie Channel, Showtime, descramblers, converters, etc. Suppliers list included. \$9.95. **CABLE FACTS**, Box 711-R, Pataskala, OH 43062.

VIDEOCYPHERII descrambling manual. Schematics, video and audio. Explains DES, Eprom, Clonemaster, 3Musketeeer, Pay-per-view (HBO, Cinemax, Showtime, adult, etc.) \$16.95, \$2.00 postage. Schematics for Videocypher Plus, \$20.00. Schematics for Videocypher 032, \$15.00. Collection of software to copy and alter Eprom codes, \$25.00. **CABLETRONICS**, Box 30502R, Bethesda, MD 20824.

K.D. VIDEO

FOR ALL YOUR CABLE TV NEEDS
WE SPECIALIZE IN DEALER PRICING

QTY	1	10	20
Jerrold (Type) SB-3	89.00	56.00	48.00
Jerrold (Type) Tri-Bi	119.00	69.00	65.00
Scientific Atlanta SA-3	129.00	80.00	75.00
Hamlin MLD-1200	99.00	59.00	45.00
Oak N-12 Vari-Sync	99.00	59.00	58.00
Jerrold 550 Converter	99.00	75.00	68.00
Jerrold 400 DRX-3DC (With Built in SB-3)	169.00	109.00	100.00

1-800-327-3407

Call us for prices on large quantities

K.D. Video PO Box 29538, Mpls., MN 55429

CABLE TV EQUIPMENT

Converters, Remote Controls, Descramblers, CD Players.

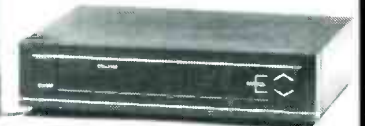

JERROLD-OAK-SCIENTIFIC ATLANTA-HAMLIN ZENITH MANY MORE CALL TODAY!

- ✓ Only quality products sold ✓ Easy to use
- ✓ Satisfaction guaranteed ✓ Knowledgeable sales staff
- ✓ Most orders shipped within 24 hours

CALL FOR YOUR FREE CATALOG

MC 1-800-228-7404 **VISA**

MAKE THE CONNECTION

WITH

NU-TEK ELECTRONICS

5114 Balcones Wood Dr.#307 Dept.298
Austin, TX. 78759

BUSINESS OPPORTUNITIES

MAKE \$50/hr working evenings or weekends in your own electronics business. Send for free facts. **MJME INDUSTRY**, Box 531, Bronx, NY 10461-0208.

YOUR own radio station! AM, FM, TV, cable. Licensed/unlicensed. **BROADCASTING**, Box 130-F4, Paradise, CA 95967.

EASY work! Excellent pay! Assemble products at home. Call for information (504) 641-8003 Ext. 5192.

MARK V ELECTRONICS, INC.

Competitive Pricing * Fast Shipping

Since 1985

ORDER IN CALIFORNIA 800-521-MARK

ORDER OUTSIDE CA 800-423-FIVE

FREE CATALOG & INFORMATION (213) 888-8988

FAX (213) 888-6868

▲ indicates the level of difficulty in the assembling of our Products. ▲ Beginner ▲▲ Intermediate ▲▲▲ Advanced ★ Fully Assembled



	TA-3600	TA-477	TA-802	TA-1000A	TA-1500
Amplifier	TA-3600	TA-477	TA-802	TA-1000A	TA-1500
Metal Cabinet	LG-1925	LG-1925	LG-1924	LG-1924	LG-1925
Transformer	#007	#003	#001	#001	#001
Kit Set	\$155.61	\$125.21	\$100.45	\$113.52	\$130.00
Assmb. Set	\$179.36	\$141.36	\$113.54	\$133.36	\$150.00



- Due to this special offer & low price, we can only exchange or repair any of these units (TA-3600, TA-477, TA-802 & TA-1000A) within 15 days of your receipt.
- The above prices are for the complete sets. For separate unit price, please see below.

AMPLIFIERS		KIT ASSEMB.	
MODEL	DESCRIPTION		
TA-28MK2	Digital Voice Memo ▲▲		\$ 30.00
TA-50A / B	Multi-Purpose Melody Generator ▲		12.84 17.20
TA-50C	Multi-Purpose Melody (Happy Birthday, Wedding March, etc.) Generator ▲		13.65 18.71
TA-120MK2	35W Class A Main Power Mono Amp. ▲▲		31.50 42.80
TA-300	30W Multi-Purpose Single Channel Amp. ▲		20.00 29.00
SM-302	60W + 60W Stereo Power Amplifier (with Mic. input) ▲▲		67.00 78.00
TA-323A	30W X 2 Stereo Pre-main Amp. ▲		31.50 42.80
TA-377A	State of the Art Fully Complementary Symmetrical FET Pre-Amp. ▲▲▲		59.95 75.00
TA-400	40W Solid State Mono Amp. ▲		28.00 34.93
TA-477	120W Mostel Power Mono Amp. ▲▲		68.00 85.00
TA-800MK2	120W + 120W Low Tim Pre-Main Stereo Power Amp. ▲▲		63.92
TA-802	80W + 80W Pure DC Stereo Main Power Amp. ▲▲		45.94 59.72
TA-1000A	100W Dynamic Class 'A' Main Power Mono Amp. ▲▲		59.69 70.58
TA-1500	100W X 2 Class 'A' DC Stereo Pre-Main Amp. ▲▲▲		73.70 95.81
TA-2200	DC Fet Super Class 'A' DC Pre-Amp. ▲▲		47.70 58.24
TA-2400A	Electronic Echo & Reverberation Amp. ★		96.00
TA-2500	HO Pre-Amp w/10 band graphic equalizer ★		68.80
TA-2800	BI-FET IC Pre-Amp w/3 way tone control ▲▲		48.90 63.57
TA-3000	Stereo Simulator (For Mono TV or Any Mono Source) ▲▲		27.00 38.50
TA-3600	300W HQ Hi-Fi Power Mono Amp. ▲▲		85.00 110.00
SM-222	7 Band Hi-Fi Graphic Equalizer ▲▲▲		26.80 38.80
SM-328	4 Channel Professional Color Light Controller ★		145.00
SM-333	Audio/Video Surround Sound Processor ▲▲▲▲		65.00 75.00
SM-666	Dynamic Noise Reduction ▲		26.00 34.00
SM-888	Universal Audio/Video KARAOKE Mixer Pre-Amp. ★		225.00
DIGITAL METERS AND CONTROL		KIT ASSEMB.	
SM-43	3 1/2" Multi-Functional Led D P M (w/ABS plastic case) ▲▲		\$ 34.50 \$ 43.00
SM-48	4 1/2" Hi-Precision D P M ▲▲▲		38.00 48.00
SM-88A	4 1/2" Hi-Precision D P M (w/ABS plastic case) ▲▲▲		41.20 52.00
SM-49	3 1/2" Multi-Functional LCD D P M (w/Hold Function) ▲▲		36.00 44.50
SM-100	150Mc Digital Frequency Counter ▲▲		79.00 90.00
FC-1000A	1 GHz Frequency Counter ★		179.00

MISCELLANEOUS		KIT ASSEMB.	
MODEL	DESCRIPTION		
TY-23B	3 Channel Color Light Controller ★		\$ 65.00
TY-25	Stereo Loudspeaker Protector ▲		14.85 20.85
TY-35	FM Wireless Microphone ▲		11.25
TY-36	AC/DC Quartz Digital Clock ▲		19.00 26.20
TY-38	Sound / Touch Control Switch ▲		12.00
TY-41MKV	Infrared Remote Control Unit (w/Case) ▲▲▲		22.00 35.00
TY-42	Bar / Dot Level Meter ▲▲		24.15 33.81
TY-43	3 1/2" Digital Panel Meter ▲		29.00 38.00
TY-45	20 Steps Bar / Dot Audio Level Display ▲▲		38.45 46.14
TY-47	Superior Electronic Roulette ▲▲		19.46 27.24
10,000u/f	80 V Capacitor (Suggested for TA-3600 TA-477 TA-1000A & TA-802)		23.00
REGULATORS		KIT ASSEMB.	
TR-355A	0-15V 5A Regulated DC Power Supply (no case & x former) ▲		\$15.65 \$ 21.76
TR-355B	0-30V 3A Regulated DC Power Supply (no case & x former) ▲		15.65 21.76
TR-503	0-50V 3A Regulated DC Power Supply (no case & x former) ▲▲		16.75 23.65
METAL CABINETS WITH ALUMINUM PANEL			
MODEL	H x W x D	MATCHING	PRICE
LG-1273	3" 12" 7"	TA-2900, TA-377A, TA-2200	\$ 22.85
LG-1684	4" 16" 8"	TA-323A, TA-377A, TA-2200	27.50
LG-1924	4" 19" 1 1/2"	TA-802, TA-1500, TA-120MK 2, TA-800 MK2, TA-1000A	32.80
LG-1925	5" 19" 1 1/2"	TA-477, TA-800 MK2, TA-1500, TA-1000A, TA-3600	35.80
LG-1983	2 1/2" x 19" 8"	TA-377A, TA-2800, TA-2200, TA-120MK 2	29.25
POWER TRANSFORMERS			
MODEL	DESCRIPTION	MATCHING	PRICE
001	28V x 2 6A to 30V x 2 6A	TA-800 MK2, TA-802, TA-820A, TA-1000A, TA-1500	\$ 27.00
002	36V x 2 3A	TR-503, TA-323A, TA-400, TA-300, TA-377A	22.00
003	40V x 2 6A	TA-477	28.00
004	24V x 2 6A	TA-120 MK 2	24.00
005	26V x 2 3A	TR-355B	16.00
006	18V x 2 5A	TR-355A	15.50
007	53V x 2 8A	TA-3600	43.00

We accept major Credit Cards, Money Orders, Checks and C.O.D. Orders. C.O.D. fee is \$5.00. Minimum order is \$20.00. • We ship by UPS ground inside US (min. \$3.00) and ship by US mail. Business & Showroom hours: (Pacific Time) Mon. thru Fri. 9:30 am to 5:00 pm Sat. 10:00 am to 5:00 pm

MARK V ELECTRONICS, INC. - 8019 E. Slauson Ave, Montebello, CA 90640



CIRCLE 93 ON FREE INFORMATION CARD

Phonvu Videophone in a Chip
 STILL FRAME TV PICTURE TELEPHONE
TRANCEIVER KIT
 Sends Slow Scan TV pictures over
 The phone line in Twelve Seconds

**Captures any TV Camera, Camcorder
 VCR, NTSC Video output and holds
 the display and sends on command**

Auto Mode allows hands free send
 and receive. Displays on any TV

IC Chip Replaces 150 SSI Dips

50 Levels of Grey Scale
 Serves as:
 TV FAX

Camera 200 x 242.5
 High Res.
 50,000
 Pixels

Phonvu
 Tel. Mon.
 Line
 Modulator
 Use
 VCR TV
 Mod.

THIS DEVICE IS COMPLETE AND
 READY TO COMMUNICATE. PLUG
 IN THE CAMERA AND TV AND GO!
 TWO SETS ARE REQUIRED FOR
 END TO END COMMUNICATION.

RECORD PICTURES TO AUDIO CASSETTE RECORDERS
 ENHANCE YOUR PHONE COMMUNICATIONS.

Videophone Chip and Schematic	48P DIP	\$59.95
A/D, DRAM, D-Reg.		\$35.00
PC Board (BARE)		\$18.95
50 Res. Cap. Diode		\$28.75
Cabinet (uncut)		\$12.75
Power Pack		\$8.75
KIT PRICE:		\$164.15
ASSEMBLED		\$235.00

PHONE and FAX Order (213) 827-1652
 Electronics Box 11148
PMC Marina Del Rey, CA 90292

**CABLE DESCRAMBLERS
 OAK M35B COMBO \$39.95**

Jerrold, Zenith, Hamlin, Sci. Atlanta, Pioneer
 & MORE! OUR PRICES ARE BELOW WHOLESALER!

CABLE+PLUS
 14417 Chase St. #481-A Panorama City, CA 91402
 1-800-822-9955 • Other Info. 1-818-785-4500
 NO CALIF. SALES — DEALERS WANTED

The One Gift That Matches Everything, Can't Be Outgrown And Doesn't Need Batteries.



U.S. Savings Bonds are the perfect gift for any occasion. They pay competitive rates and will earn interest for 30 years—guaranteed. For more information, call 1-800 US BONDS.

CELEBRATE AN AMERICAN TRADITION
50 YEARS OF U.S. SAVINGS BONDS

A public service of this publication.



2-1/2" SANYO TWEETER

Paper cone with gold tone dust cap. 8 oz. magnet. 8 ohm. 1/2" ferro fluid voice coil. Power handling: 50W RMS, 70W max. Frequency response: 3K-20KHz.

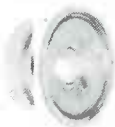

#RD-271-020 \$1⁹⁵ \$1⁷⁵ 95c
 (1-9) (10-59) (60-up)

SUPER HORN TWEETER

Original piezo tweeter made by Motorola. SPL=94 dB 2.83V/1M. Response: 4KHz-27KHz. Handles approximately 50 watts.



#RD-270-010 \$5³⁰ \$4⁵⁰ \$3⁹⁵
 (1-9) (10-79) (80-up)

2" DOME MIDRANGE

Textile dome midrange made by Philips. 8 ohm. SPL=90 dB 1W/1M. 30W RMS, 40W max. Response: 550-5KHz.



#RD-280-210 \$27³⁰ \$25⁷⁰
 (1-3) (4-up)

15" SUBWOOFER



Dual voice coil. 40 oz. magnet. 6 ohm imp. 100W RMS, 140W max. Response: 20-1.2KHz. Resonant frequency: 21Hz. SPL=93 dB 1W/1M.

#RD-290-190 \$54⁵⁰ \$49⁸⁰
 (1-3) (4-up)

SUBWOOFER COVER

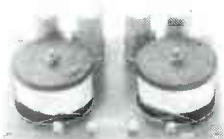

200W RMS crossover designed specifically for use with dual voice coil subwoofers. 12 dB per octave roll-off at 150Hz.

#RD-260-220 \$28⁸⁰ \$24⁴⁰

10" POLY WOOFER

Medium duty 60W RMS, 80W max. 14 oz. magnet. Response: 25-2.5KHz. fs=28Hz.



#RD-290-096 \$18⁵⁰ \$16⁹⁰
 (1-3) (4-up)

TITANIUM COMPOSITE TWEETER

The advantages of both hard and soft dome technologies. 8 ohm. Ferro fluid cooled voice coil. SPL=90 dB 1W/1M 50W RMS, 70W max. 4" round. Polydax #DTW100T125.



#RD-270-047 \$27⁵⁰ \$24⁸⁰
 (1-9) (10-up)

SPEAKER BUILDING BOOK

Revised edition of David Weems' best selling book. Learn to build low cost speakers that rival the high priced models.



#RD-500-021 \$16⁹⁵

12" CAST FRAME WOOFER



12" woofer made in the USA by Eminence. Paper cone and dust cap with treated cloth surround. 80 oz. magnet. 2-1/2" vented voice coil. 8 ohm. 170W RMS, 235W max. 40-4.5KHz response.

#RD-290-147 \$72⁹⁰ \$69⁵⁰
 (1-3) (4-up)

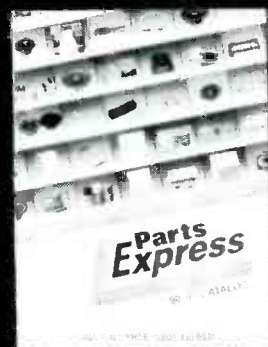

CALL TOLL FREE
1-800-338-0531

FREE
 CATALOG

QUALITY PARTS • DISCOUNT PRICES • FAST SHIPPING

ALL ELECTRONICS CORP.

12 Vdc STARTER SOLENOID

Brand NEW automotive-type solenoid (relay). 12Vdc, 4 ohm coil. SPST normally open. Negative chassis ground.

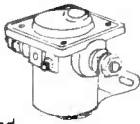

Designed for switching very heavy loads. 5/16" copper screws on switch terminals.
CAT# SOL-32 \$4.50 each

ROTARY BCD SWITCH

EECO # 2310-02G BCD encoded, 10 position rotary switch. DIP configuration fits in standard 8 pin I.C. socket. Right angle style. Screw-driver actuation. 0.42" cube.
CAT# RDIP-2 \$1.75 each
10 for \$16.00 • 100 for \$145.00



FLASH ASSEMBLY

New compact flash assembly from a U.S. manufacturer of cameras. Operates on 3 Vdc and measures 2 1/2" x 1 1/4". Ideal for use as a strobe, warning light or attention getter. Includes hook-up diagram.
CAT# FSH-1 \$3.75 each
10 for \$35.00 • 100 for \$325.00

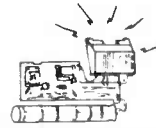

New Reduced Price PHOTOFLASH CAP.

Rubicon CE 210 Mfd 330 Volt photoflash capacitor. 0.79" dia. X 1.1" high. These are new capacitors that have been prepped with 1.4" black and red wire leads soldered to the terminals. CAT# PPC-210 \$1.25 each
10 for \$11.00 • 100 for \$100.00
Large quantities available. Call for pricing.



SWITCHES

DIP P.C. PUSHBUTTON

ITT Shadow Digitast Series SE S.P.D.T. momentary pushbutton. Mounts in 14 pin DIP configuration. Designed for low current switching applications. Grey keycap is 0.68" X 0.67".
CAT# PB-28 \$1.00 each
10 for \$9.50 • 100 for \$85.00



THUMBWHEEL SWITCH

1 pole 10 position decimal encoded switches which interlock to make up desired number or digits. Terminates to 11 pc pins (1 common and 10 poles). Each section measures .31" wide X .20" high X .78" deep. End plates can be added to form a .94" high bezel.
CAT# SWTH-9 \$1.25 each
10 for \$10.00
2 END PLATES
CAT# SW-9EC \$1.00/Set



MINIATURE TOGGLE

Rated: 3 amps @ 120 Vac

S.P.D.T. (ON-ON) P.C. mount
CAT# MTS-4PC \$1.00 each
10 for \$9.00 • 100 for \$80.00
S.P.D.T. (ON-OM) solder lugs
CAT# MTS-4 \$1.35 each
10 for \$12.50 • 100 for \$110.00
D.P.D.T. (ON-ON) solder lugs
CAT# MTS-8 \$1.75 ea. 10 for \$15.00
D.P.D.T. (ON-ON) P.C. mount
CAT# MTS-8PC \$2.00 ea. 10 for \$17.50



POWER SUPPLIES

12 Vdc 5 AMP

ACDC Electronics # 12N5 or equiv.
Input: 100-240 Vac (wired for 115 Vac)
Output: 12 Vdc @ 5 amps.
Open frame style. 7" X 4 3/4" X 3" high. Regulated. CAT# PS-125 \$37.50 each



24 Vdc 2.4 AMP

Power-One Inc. #HC-24-2.4
Input: 115/230 Vac (wired for 115 Vac)
Output: 24 Vdc @ 2.4 amps. Open frame style. 5.62" X 4.87" X 2.50" CSA listed. CAT# PS-2424 \$30.00 each

RECHARGEABLE BATTERIES

6 Volt 1 Amp/Hour

Japan Storage Battery Co. Portalac# PE6V1
6 Volt 1 Ah rechargeable sealed lead-acid (gell cell). 2" X 1.635" X 2" high. Batteries are prepped with 5" black and red leads terminated with 2 pin connector.
CAT# GC-61 \$4.75 each
10 for \$42.50



Nickel-Cad

AAA SIZE \$1.50 each
1.2 volts 180 mAh
CAT# NCB-AAA
AA SIZE \$2.00 each
1.25 volts 500 mAh
CAT# NCB-AA
AA SIZE \$2.20 each
WITH SOLDER TABS
CAT# NCB-SAA
C SIZE \$4.25 each
1.2 volts 1200 mAh
CAT# NCB-C
D SIZE \$4.50 each
1.2 volts 1200 mAh
CAT# NCB-D



HEAVY DUTY "C"

YUASA 1800C Nickel-cad heavy duty "C" cell
1.2 volt, 1800 mah
Price reduced on 10 or more.
CAT# HDNCB-C
10 for \$42.50/100 for \$375.00



HALL EFFECT SENSOR

Microswitch #SS41
Tiny, solid state switch reacts instantly to proximity of magnetic field. Operates at extremely high speeds, up to 100 khz. Case size: 0.12" X 0.17" X 0.06" thick. 4.5 Vdc to 24 Vdc supply voltage. 10 ma. sink type digital output. Operating gauss - 15 to 40. P.C. leads.
CAT# HESW-3 \$1.00 each • 10 for \$9.00
100 for \$85.00 • 1000 for \$750.00



INSTRUMENT ENCLOSURES

High quality molded ABS instrument enclosures. Integrated PC board standoffs and two sets of vertical mounting slots for front and rear sub panels. All enclosures are 6" wide X 6 1/4" deep. Choice of three hts. Includes non-skid rubber feet and hardware. Available in beige, ivory, black, and blue.
Part No. CAT#
2 1/4" CAT# MB-A \$7.50 each 10 for \$65.00
2 5/8" CAT# MB-B \$7.75 each 10 for \$67.50
3" CAT# MB-C \$8.00 each 10 for \$70.00
Please specify color.



RG-11/U VIDEO CABLE

100 ft. or 200 ft. rolls of RG 11/U 75 ohm cable terminated to heavy duty F connectors. Includes 75 ohm terminator and F-61 splicer on one end. New cables manufactured for IBM PC networks. IBM P/N 1501908 COM/SCOPE.
CAT# RG-11-1 100 ft. roll \$15.00
CAT# RG-11-2 200 ft. roll \$27.50



Experimenters Delight Atari 5200 Video Game

Atari video game controllers returned to the dealer because of various defects. None of them work properly, but they have lots of great parts. A RF video modulator, eight 16K dynamic RAMs in sockets, microprocessors and D-A converters in sockets, two voltage regulators on a heavy-duty heatsink and lots of other ICs, capacitors, resistors, connectors and other component. Does not include the power transformer or controls (joysticks).
CAT# A-5200 \$7.50 each • 2 for \$13.50 SOLD AS-IS For Parts Only.



L.E.D.'s

Standard JUMBO

Diffused T 1-3/4 size (5 mm)

RED CAT# LED-1
10 for \$1.50 • 100 for \$13.00
GREEN CAT# LED-2
10 for \$2.00 • 100 for \$17.00
YELLOW CAT# LED-3
10 for \$2.00 • 100 for \$17.00

FLASHING LED

W/ built in flashing circuit 5 volt operation. T 1-3/4 (5mm)

RED \$1.00 each
CAT# LED-4 10 for \$9.50
GREEN \$1.00 each
CAT# LED-4G 10 for \$9.50
YELLOW \$1.00 each
CAT# LED-4Y 10 for \$9.50

LED HOLDER

Two piece holder.
CAT# HLED 10 for 65¢

OPTO SENSORS

Honeywell # HOA 0866-N55 U-shaped opto sensor. 1/8" gap. 4 pc leads. CAT# OSU-8 75¢ each



TRW# OPB-818 U-shaped opto switch. 0.2" gap between sensor and emitter. CAT# OSU-9 75¢ each



TRW# OPB 822SD Reflective scanner module. U-shaped device with 4 leads each side (8 total) 0.09" gap. 0.75" mounting centers. CAT# OSU-10 75¢ each



TRW# OPB-708 Wedge-shaped reflective opto sensor. CAT# OSR-5 75¢ each



KITS

L.E.D. FLASHER KIT

Two L.E.D.'s flash in unison when a 9 volt battery is attached. This kit includes a p.c. board, all the parts and instructions to make a simple flasher circuit. A quick and easy project for anyone with basic soldering skills.
CAT# LEDKIT \$1.75 per kit



L.E.D. CHASER KIT

Build this variable speed led chaser. 10 leds flash sequentially at whatever speed you set them for. Easy to build kit includes pc board, parts and instructions. Ideal for special lighting effects, costumes, etc. Operates on 3 to 9 volts. PC board is 5" X 2.25". A great one hour project.
CAT# AEC \$6.50 each

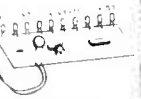

STEPPING MOTOR CONTROLLER KIT

Learn about stepping motors while building this simple circuit. Includes circuit board, stepping motor and all parts except 12 Vdc power supply. CAT# SMK12 \$18.00 each



METRONOME KIT

This simple device can be set to click from 20 to 1,000 beats per minute. 0.182" dia. X .08" high. 0.18" long leads.
CAT# METRO \$3.75 each



PHOTO RESISTOR

1,000 ohms bright light. 16K ohms dark. 0.182" dia. X .08" high. 0.18" long leads.
CAT# PRE-7 2 for \$1.00
100 for \$45.00 • 1000 for \$400.00

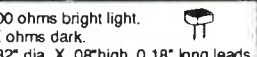

ORDER TOLL FREE 1-800-826-5432

FAX (818) 781-2653 • INFORMATION (818) 904-0524

Call Or Write For Our Free 60 Page Catalog

Outside the U.S.A. send \$2.00 postage for a catalog.

Minimum Order \$10.00 • All Orders Can Be Charged To Visa, Mastercard Or Discovercard • Checks and Money Orders Accepted By Mail • California, Add Sales Tax • Shipping And Handling \$3.50 For the 48 Continental United States - All Others Including Alaska, Hawaii, P.R. And Canada Must Pay Full Shipping • Quantities Limited • No C.O.D. • Prices Subject to change without notice.



MAIL ORDERS TO: ALL ELECTRONICS CORP • P.O. BOX 567 • VAN NUYS, CA 91408

CIRCLE 107 ON FREE INFORMATION CARD

Top Performance

Test / Measurement
and Prototype Equipment

GoldStar 20MHz Oscilloscope

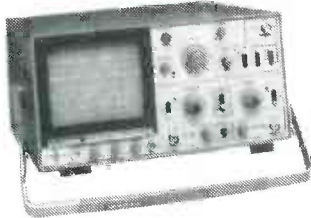

Features:

- 6" rectangular CRT display, internal graticule & scale
- Phase difference measurements between two signals using X-Y scope or Dual Trace
- Two different scale probes: x1 and x10
- Bandwidth from DC to 20MHz
- Includes: Two 40MHz probes, two fuses, power cord, operation manual, schematics and block and wiring diagrams
- High sensitivity: 1mV/div
- Two-year manufacturer's warranty

GS7020.....\$499.95

Jameco Logic Pulser



- Compatible with TTL, DTL, RTL, HTL, HNHL, MOS and CMOS ICs • 1MΩ Sync input impedance • Pulsar mode output current: 10mA • Square wave current output: 5mA • Audible tone

LP540.....\$16.95

Jameco Logic Probe



- Max Frequency 80MHz • Minimum detectable pulse: 10ns • 120KΩ input impedance • Max. supply voltage: ±25V • TTL threshold: (Lo)+0.8V -0.1V (Hi) -2.3V ±0.2V • CMOS threshold: (Lo) 30% VCC ±10% (Hi) 70%VCC ±10%

MS104.....\$24.95

PROTOTYPING PRODUCTS Jameco Solderless Breadboards

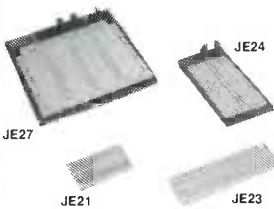

Part No.	Dim. L" x W"	Contact Points	Binding Posts	Price
JE21	3.25 x 2.125	400	0	\$4.95
JE23	6.5 x 2.125	830	0	\$6.95
JE24	6.5 x 3.125	1,360	2	\$12.95
JE25	6.5 x 4.25	1,660	3	\$17.95
JE26	6.875 x 5.75	2,390	4	\$22.95
JE27	7.25 x 7.5	3,220	4	\$32.95

Metex Digital Multimeters

General Specs:

- Handheld, high accuracy • AC/DC voltage, AC/DC current, resistance, diodes, continuity, transistor hFE
- Manual ranging w/ overload protection



- M3650 & M4650 only: • Also measure frequency and capacitance

- M4650 only: • Data hold switch • 4.5 digit

M3610	3.5 Digit Multimeter	\$59.95
M3650	3.5 Digit Multimeter w/Frequency & Capacitance	\$74.95
M4650	4.5 Digit w/Frequency, Capacitance and Data Hold Switch	\$99.95

Handheld Multimeter

- 3.5 digit LCD with automatic polarity indication
- AC/DC voltage measurement up to 500 volts
- AC/DC current measurement up to 200mA
- Resistance measurement up to 20MΩ • Continuity checker with audible tone • Diode and logic tester • Auto/manual range and data hold functions • All range protection and function indications

DMM905.....\$39.95

Global Specialties ProtoBoard® Design Station

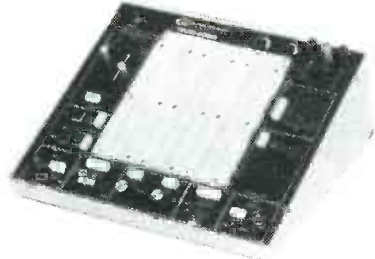

Features:

- Ideal for analog, digital and microprocessor circuits
- Triple DC regulated power supplies, +5V, +15V, -15V
- 8 logic indicators
- Two debounced push-button switches
- Function generator with sine, square, triangle and TTL waveforms
- Includes power supply, instrumentation and breadboarding

PB503.....\$299.95

A.R.T. EPROM Programmer



- Programs all current EPROMs in the 2716 to 27512 range plus the X2864 EEPROM
- RS232 port • Software included

EPP.....\$199.95

UVP EPROM Eraser



- Erases all EPROM's • Erases 1 chip in 15 minutes and 8 chips in 21 min
- UV intensity, 6800 UW/CM²

DE4.....\$79.95

EPROMs - for your programming needs

Part No.	Price	Part No.	Price	Part No.	Price
TMS2516	\$4.25	2764-20	\$3.95	27256OTP	\$3.75
TMS2532-35	9.95	2764-25	3.75	27256-15	5.95
TMS2532A	7.95	2764-45	3.49	27256-20	5.25
TMS2564	5.95	2764A-20	3.95	27256-25	4.75
TMS2716	5.95	2764A-25	3.25	27C256-15	5.95
1702A	3.95	27C64-15	3.95	27C256-20	4.95
2708	4.95	27C64-25	3.25	27C256-25	4.49
2716	3.49	27128OTP	2.95	27512OTP	4.95
2716-1	3.95	27128-20	6.95	27512-20	6.95
27C16	4.25	27128-25	4.95	27512-25	5.95
2732	4.95	27128A-15	5.95	27C512-15	6.95
2732A-20	3.95	27128A-20	4.49	27C512-20	6.49
2732A-25	3.49	27128A-25	4.25	27C512-25	5.95
2732A-45	2.95	27C128-15	5.95	27C010-15	11.95
27C32	3.95	27C128-25	5.75	68766-35	9.95

Soldering and Desoldering Stations

- 60 Watt Analog Display Soldering Station • Electronic temperature control from 200° to 878°F • Cartridge heating element for a longer life of the soldering tip

XY1683.....\$69.95

- 30 Watt Electronic Temperature Controlled Desoldering Station • Electronic temperature control from 212° to 842°F • Self contained high rotary vacuum pump

XY999.....\$299.95



JAMECO

24 Hour Order Hotline
(415) 592-8097

FAX: (415) 592-2503
(415) 595-2664

• Partial Listing • Over 4000 Electronic and Computer Components in Stock!

CIRCLE 114 ON FREE INFORMATION CARD

Widest Selection

24 Hours A Day!

Computer Products
and Electronic Components

Assemble Your own Computer Kit!

Jameco 16MHz 80386SX Desktop Computer Kit

- Building your own computer provides you with a better understanding of components and their functions
- In-depth assembly instructions included
- Have your new computer assembled and running in an evening, using common tools
- Software included
- Purchase computer kits configured by Jameco or design your own

Jameco 16MHz 80386SX Desktop Computer Kit

Includes:

- 80386SX Motherboard with 2MB RAM (expandable to 8MB)
- 101-key enhanced keyboard
- Multi I/O Card
- Toshiba 1.44MB, 3.5" DSHD floppy disk drive
- Baby sized desktop case
- 200 Watt power supply
- DR DOS 5.0 by Digital Research and Diagsoft's QAPLUS diagnostic software

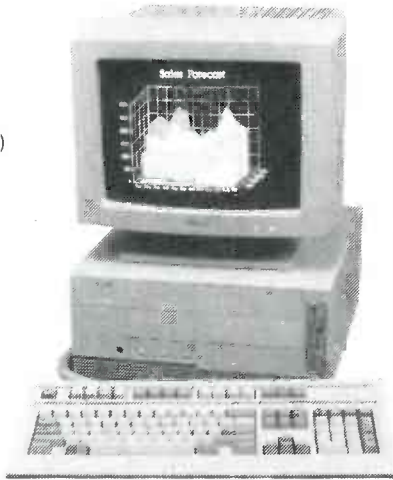

\$1199.95
JE3816 monitor extra

Hard Drives



Conner (16-bit IDE)

CP3044	40MB 3.5" Low Profile.....	\$469.95
CP3184	80MB 3.5" HH.....	\$649.95
CP3104	100MB 3.5" HH.....	\$699.95
ADP20	Host Adapter.....	\$29.95

Relisys 14" VGA Color Monitor



- Max resolution: 720 x 480
- Bandwidth: 30MHz
- Input: DB15-pin (analog)

RE9513.....\$449.95

Jameco 16-bit VGA Card



- Supports VGA, EGA, CGA, MDA and Hercules modes • Comes with 256KB video RAM upgradable to 512KB (eight 41464-80) • Capable of 640 x 480 with 256 colors, 800 x 600 with 16 colors

VG2000.....\$149.95

JAMECO

24 Hour Order Hotline
(415) 592-8097

FAX: (415) 592-2503
(415) 595-2664

1355 Shoreway Road
Belmont, CA 94002

Look to Jameco.....

- Wide selection of integrated circuits and components
- Quality prototype and test equipment
- Computer kits and accessories

Additional items that Jameco offers:

- Tools
- Cables
- Connectors
- Data Books
- Motherboards
- Memory
- Math Coprocessors
- Computer Accessories
- Power Protection Equipment
- *Much, much more !*

Let us show you what we have to offer,
call or write for the latest Jameco catalog!

\$50.00 Minimum Order

Data Sheets - 50c each

For a FREE 90-Page catalog send \$2.00 to cover first class Postage and Handling
© 1991 Jameco Electronics 4/91

CA Residents Add

6.00%, 6.50% or 7.00% Sales Tax
Shipping, handling and insurance are additional.
(Costs may vary according to weight and shipping method)
Terms: Prices subject to change without notice.
Items subject to availability and prior sale.

Complete list of terms/warranties is available upon request.
IBM is a registered trademark of International Business Machines



Please refer to Mail Key 2 when ordering

Integrated Circuits

Part No.	1-9	10+	Part No.	1-9	10+
74LS00	\$.25	\$.15	74LS154	\$1.29	\$1.19
74LS02	.25	.15	74LS155	.49	.39
74LS03	.29	.19	74LS156	.49	.39
74LS04	.25	.15	74LS157	.45	.35
74LS05	.28	.18	74LS158	.39	.29
74LS06	.59	.49	74LS166	.79	.69
74LS07	.59	.49	74LS169	.99	.89
74LS08	.28	.18	74LS173	.49	.39
74LS10	.25	.15	74LS175	.39	.29
74LS11	.29	.19	74LS181	1.39	1.29
74LS13	.35	.25	74LS189	3.95	3.85
74LS14	.49	.39	74LS190	.59	.49
74LS20	.28	.18	74LS191	.59	.49
74LS21	.29	.19	74LS193	.69	.59
74LS27	.35	.25	74LS194	.69	.59
74LS30	.28	.18	74LS221	.69	.59
74LS32	.28	.18	74LS240	.59	.49
74LS38	.35	.25	74LS241	.59	.49
74LS42	.49	.39	74LS323	2.49	2.25
74LS47	.85	.75	74LS541	1.09	.99
74LS48	.85	.75	74LS590	5.95	5.75
74LS112	.39	.29	74LS670	.89	.79
74LS122	.55	.45	74LS688	2.19	1.95
74LS123	.49	.39	81LS95	.99	.89
74LS125	.49	.39	81LS97	.99	.89

Miscellaneous Components

Potentiometers

Values available (insert ohms into space marked "XX"):
500Ω, 1K, 5K, 10K, 20K, 50K, 100K, 1MEG

43PXX	3/4 Watt, 15 Turn \$.99
63PXX	1/2 Watt, 1 Turn \$.89

Transistors And Diodes

PN2222.....	\$.12	1N4735.....	\$.25	2N4401.....	\$.15
PN2907.....	.12	2N3904.....	.12	1N4148.....	.07
1N4004.....	.10	1N751.....	.15	2N3055.....	.69
2N2222A.....	.25	C106B1.....	.49	1N270.....	.25

Switches

JMT123	SPDT, On-On (Toggle) \$1.25
206-8	SPST, 16-pin (DIP) \$1.09
MPC121	SPDT, On-Off-On (Toggle) \$1.19
MS102	SPST, Momentary (Push-Button) \$.39

D-Sub Connectors and Hoods

DB25P	Male, 25-pin \$.65	DB25H	Hood \$.39
DB25S	Female, 25-pin \$.75			

LEDs

XC209R	T1, (Red) \$.14	XC556R	T1 3/4, (Red)	... \$.12
XC556G	T1 3/4, (Green)	... \$.16	XC556Y	T1 3/4, (Yellow)	... \$.16

IC Sockets

Low Profile		Wire Wrap (Gold) Level #2	
8LP \$.11	8WW \$.49
14LP12	14WW65
16LP13	16WW69
24LP19	24WW 1.05
28LP22	28WW 1.29
40LP28	40WW 1.79

Soldertail Standard & Header Plug Sockets Also Available

• Customer Service • Technical Assistance • Credit Department • All Other Inquiries • (415) 592-8097 • 7AM - 4PM P.S.T.

CIRCLE 114 ON FREE INFORMATION CARD

THE ELECTRONIC GOLDMINE

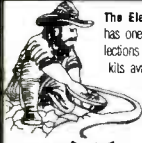

The Electronic Goldmine has one of the greatest selections of unique electronic kits available in the world! We have over 130 kits and over 1,400 unique, bargain priced, components in our catalog!

FREE CATALOG
with OVER 1400 DIFFERENT ITEMS INCLUDING 135 KITS! REQUEST YOUR COPY TODAY!

INEXPENSIVE GEIGER COUNTER KIT

Probably the lowest priced Geiger counter kit available in the world today! Features sensitive thin walled Geiger Mueller tube and piezoelectric speaker that emits clicks in proportion to the radiation level. Detects Beta and Gamma rays. Will detect radium dials on old watches, clocks, background radiation, nuclear fallout, etc. Only 2" x 1.58" Operates from one 9V battery (not included). Complete with all parts, PC board and instructions.

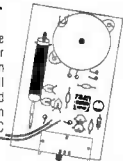

C6447 \$39.95

4KV TRIGGER COIL

Use with any strobe tube that needs a 3 lead 4KV trigger.

N1700 \$1.25 EA
100 for \$80.00

INVERTER TRANSFORMER

Small 4 lead transformer for use with 555 IC to convert 12VDC to 250V for strobe/fluorescent tubes with schematic.

N1703 \$2.00 EA
1,000 for \$1,500

MINERALIGHT BLACKLIGHT LAMP

Portable short wave mineral light made by DVP. Model LVG-4 features fully portable operation from four AA batteries (not included). This light is rugged and has the famous 5000 hour SW filter to cause fluorescent minerals to glow brightly.

G812 \$29.95

PLASTIC ZIPPER CLOSE BAGS

We now offer high quality 2Mil thick zipper close bags with white block to write on. These re-closeable bags feature a zipper locking top for convenient storage of small electronic parts, hardware, etc. We have the following sizes:

Sold in multiples of 100 only.
2" X 3" G663 100/\$3.30
3" X 4" G664 100/\$3.75
3" X 5" G665 100/\$4.00
4" X 6" G666 100/\$5.50

RARE EARTH SUPER MAGNET 2

Many times stronger than other magnets, these are the world's strongest commercially available magnets for this size. Small size only about 1" x 5/8" x 1/2" yet can lift 12 to 15 lbs. Try to remove this magnet from a steel plate and you'll find that unless you slide it, you can't get it off. Great for thousands of experiments and applications. Normally these sell for \$60 each, but these are surplus and have a few scratches (does not effect performance).

G860 \$11.00

MINIMUM ORDER: \$10.00 plus \$3.00 shipping and handling. We accept MC, Visa and Money Orders. SEND ORDERS TO: The Electronic Goldmine P.O. Box 5408 Scottsdale, AZ 85261 PHONE ORDERS (602) 451-7454 FAX ORDERS (602) 451-9495

CIRCLE 176 ON FREE INFORMATION CARD

ADVERTISING INDEX

RADIO-ELECTRONICS does not assume any responsibility for errors that may appear in the index below.

Free Information Number	Page	
179		SCO Electronics 62
189		Sencore CV4
75		Star Circuits 25
107		TECI 79
—		Tektronix 11
92		The SPEC-COM Journal 70
187		Unicorn 93
188		Viejo Publications 42
180		U.S. Cable 62
177		WPT Publications 79
—		Wholesale Cable 92
178		Xandi Electronics 77
108		AMC Sales 70
75		Ace Products 77
107		All Electronics 95
—		Amazing Concepts 91
77		B&K Precision 16
67		Banner Technical Books 76
109		C&S Sales 69
—		CIE 5,31
—		Cable Ready Company 98
50		Caig Laboratories 25
181		Cheneko Products 77
—		Command Productions 42
55		Contact East 77
58		Cook's Institute 68
185		D&D Electronics 15
127		Deco Industries 77
176		Electronic Goldmine 98
—		Electronics Book Club 23
—		EE&D Book Club 38
121		Fluke Manufacturing CV2
184		General Technics 77
182		Global Specialties 32
—		Grantham College 67
86		Heathkit 17
—		ISCET 76
114		Jameco 96,97
104		Jan Crystals 68
—		King Wholesale 89
53		MD Electronics 90
93		Mark V. Electronics 91
61		Microprocessors Unltd. 86
—		NRI Schools 21,83
71		NTE Electronics 7
183		Optoelectronics 13
56		Parts Express 94
—		Perfect Cable 89
78		Radio Shack 3

ADVERTISING SALES OFFICE

Gernsback Publications, Inc.
500-B Bi-County Blvd.
Farmingdale, NY 11735
1-(516) 293-3000
President: Larry Steckler

For Advertising ONLY
516-293-3000
Fax 1-516-293-3115
Larry Steckler
publisher

Arlene Fishman
advertising director
Denise Haven
advertising assistant
Christina Estrada
advertising associate
Kelly McQuade
credit manager

Subscriber Customer Service
1-800-288-0652

Order Entry for New Subscribers
1-800-999-7139
7:00 AM - 6:00 PM M-F MST

SALES OFFICES

EAST/SOUTHEAST

Stanley Levitan, Eastern Sales Manager
Radio-Electronics
259-23 57th Avenue
Little Neck, NY 11362
1-718-428-6037, 1-516-293-3000
Fax 1-718-225-8594

MIDWEST/Texas/Arkansas/Okla.

Ralph Bergen, Midwest Sales Manager
Radio-Electronics
540 Frontage Road—Suite 339
Northfield, IL 60093
1-708-446-1444
Fax 1-708-446-8451

PACIFIC COAST/Mountain States

Marvin Green, Pacific Sales Manager
Radio-Electronics
5430 Van Nuys Blvd. Suite 316
Van Nuys, CA 91401
1-818-986-2001
Fax 1-818-986-2009

SAVE MONEY. DON'T RENT!

CABLE TV DESCRAMBLERS, CONVERTERS, & ACCESSORIES.

Save hundreds of dollars
owning instead of renting
from the cable company.

Easy to order
and install.

Name brands—

Pioneer, Oak, Panasonic,
Jerrold, Scientific Atlanta
and more.

We're famous for
lowest prices,
excellent service and immediate delivery.
All products fully warranted. Your
satisfaction is 100% guaranteed.

CABLE READY Company

CALL FOR FREE FULLY ILLUSTRATED
16-PAGE COLOR CATALOG.

(800) 234-1006

Countersurveillance

Never before has so much professional information on the art of detecting and eliminating electronic snooping devices—and how to defend against experienced information thieves—been placed in one VHS video. If you are a Fortune 500 CEO, an executive in any hi-tech industry, or a novice seeking entry into an honorable, rewarding field of work in countersurveillance, you must view this video presentation again and again.

Wake up! You may be the victim of stolen words—precious ideas that would have made you very wealthy! Yes, professionals, even rank amateurs, may be listening to your most private conversations.

Wake up! If you are not the victim, then you are surrounded by countless victims who need your help if you know how to discover telephone taps, locate bugs, or “sweep” a room clean.

There is a thriving professional service steeped in high-tech techniques that you can become a part of! But first, you must know and understand Countersurveillance Technology. Your very first insight into this highly rewarding field is made possible by a video VHS presentation that you cannot view on broadcast television, satellite, or cable. It presents an informative program prepared by professionals in the field who know their industry, its techniques, kinks and loopholes. Men who can tell you more in 45 minutes in a straightforward, exclusive talk than was ever attempted before.

Foiling Information Thieves

Discover the targets professional snoopers seek out! The prey are stock brokers, arbitrage firms, manufacturers, high-tech companies, any competitive industry, or even small businesses in the same community. The valuable information they filch may be marketing strategies, customer lists, product formulas, manufacturing techniques, even advertising plans. Information thieves eavesdrop on court decisions, bidding information, financial data. The list is unlimited in the mind of man—especially if he is a thief!

You know that the Russians secretly installed countless microphones in the concrete work of the American Embassy building in Moscow. They converted



**CALL
TOLL
FREE**

1-800-522-6260

**HAVE YOUR
VISA or MC CARD
AVAILABLE**

what was to be an embassy and private residence into the most sophisticated recording studio the world had ever known. The building had to be torn down in order to remove all the bugs.

Stolen Information

The open taps from where the information pours out may be from FAX's, computer communications, telephone calls, and everyday business meetings and lunchtime encounters. Businessmen need counselling on how to eliminate this information drain. Basic telephone use coupled with the user's understanding that someone may be listening or recording vital data and information greatly reduces the opportunity for others to purloin meaningful information.

The professional discussions seen on the TV screen in your home reveals how to detect and disable wiretaps, midget radio-frequency transmitters, and other bugs, plus when to use disinformation to confuse the unwanted listener, and the technique of voice scrambling telephone communications. In fact, do you know how to look for a bug, where to look for a bug, and what to do when you find it?

Bugs of a very small size are easy to build and they can be placed quickly in a matter of seconds, in any object or room. Today you may have used a telephone handset that was bugged. It probably contained three bugs. One was a phony bug to fool you into believing you found a bug and secured the telephone. The second bug placates the investigator when he finds the real thing! And the third bug is found only by the professional, who continued to search just in case there were more bugs.

The professional is not without his tools. Special equipment has been designed so that the professional can sweep a room so that he can detect voice-activated (VOX) and remote-activated bugs. Some of this equipment can be operated by novices, others require a trained countersurveillance professional.

The professionals viewed on your television screen reveal information on the latest technological advances like laser-beam snoopers that are installed hundreds of feet away from the room they snoop on. The professionals disclose that computers yield information too easily.

This advertisement was not written by a countersurveillance professional, but by a beginner whose only experience came from viewing the video tape in the privacy of his home. After you review the video carefully and understand its contents, you have taken the first important step in either acquiring professional help with your surveillance problems, or you may very well consider a career as a countersurveillance professional.

The Dollars You Save

To obtain the information contained in the video VHS cassette, you would attend a professional seminar costing \$350-750 and possibly pay hundreds of dollars more if you had to travel to a distant city to attend. Now, for only \$49.95 (plus \$4.00 P&H) you can view *Countersurveillance Techniques* at home and take refresher views often. To obtain your copy, complete the coupon below or call toll free.

RADIO-ELECTRONICS VIDEO OFFER RE

500-B B]-County Blvd.
Farmingdale, NY 11735

Please rush my copy of the Countersurveillance Techniques Video VHS Cassette for \$49.95 plus \$4.00 for postage and handling.

No. of Cassettes ordered _____

Amount of payment \$ _____

Bill my VISA MasterCard

Card No. _____

Expire Date _____ / _____

Signature _____

Name _____

Address _____

City _____ State _____ ZIP _____

All payments in U.S.A. funds. Canadians add \$4.00 per VHS cassette. No foreign orders. New York State residents add applicable sales tax.

Introducing a new companion to your
VA62A Universal Video Analyzing System!

Isolate All Playback Or Record Problems In All VCRs . . . Now And In The Future, Or Your Money Back!

New!



VA62A Universal Video Analyzer

VC93 All Format VCR Analyzer
Patent Pending

**Now you'll have everything to completely analyze all VCR
RF, video, audio, and servo problems.**

Automatic VCR Analyzing: (patent pending)

Automatically determine if the VCR has a capstan servo (speed or phase), cylinder servo (speed or phase), luminance, or chrominance circuit defect in the time it takes to connect to the video and audio line outputs.

Exclusive Video And Audio Head Substitution:

Never again install another video or Hi-Fi stereo head without being 100% positive it will fix the problem. The VC93 provides exclusive video and audio head substitution signals to distinguish head problems from all other circuit problems for all VCR formats.

Isolate Defects Throughout The Entire VCR:

Exclusive phase- and chroma-locked drive signals can be injected into any stage isolating problems from the heads to the output. Every signal you need, including: FM luminance, chroma, video, and head switching (SW30) signals.

Includes The Extra Features To Complete Your

Servicing Needs: You get an internal NTSC video pattern, standard video and audio line outputs, a servo sub bias supply to 10 VDC, an autoranged DC and PPV meter, plus it supports all common VCR formats.

Call 1-800-SENCORE ext. 542 for more information!
(736-2673)

CIRCLE 189 ON FREE INFORMATION CARD